

FAIRFAX COUNTY

# Bicycle Parking Guidelines

March 2024 / Draft

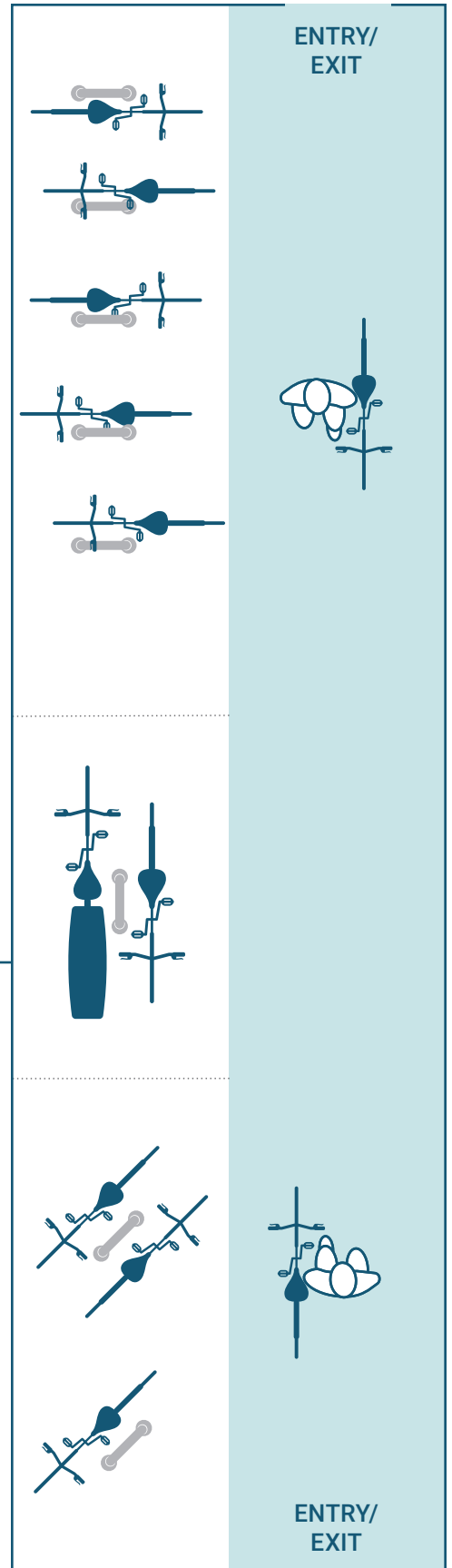
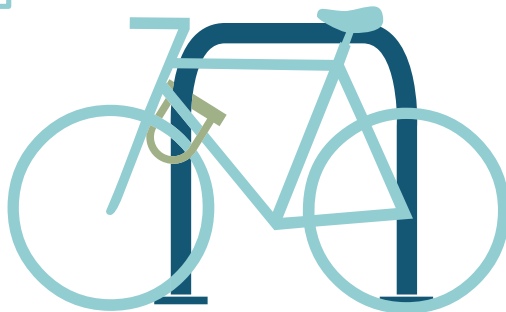

# Contents

<b>1: Introduction</b> .....	<b>2</b>
<b>2: Key Bicycle Parking Principles</b> .....	<b>3</b>
Facility Type .....	3
Quality .....	3
Location .....	3
Access .....	3
<b>3: Basic Bike Parking Design Guidance</b> .....	<b>4</b>
Basic Bike Parking Space Requirements .....	4
Acceptable Rack Types .....	5
Parking and Wayfinding Signage .....	5
<b>4: Short-Term Bicycle Parking</b> .....	<b>6</b>
Location .....	6
Access .....	8
Rack Types .....	8
Additional Equipment and Design Options .....	8
Markings .....	9
Maintenance .....	10
<b>5: Long-Term Bicycle Parking</b> .....	<b>11</b>
Type of Facilities .....	11
Location .....	12
Access .....	12
Equipment .....	12
Security Recommendations .....	14
Recommended Additional User Amenities .....	15
Bike Room Maintenance .....	15
<b>6: Recommended Short-Term and Long-Term     Bicycle Parking Ratio</b> .....	<b>16</b>



# 1: Introduction

*Bicycle parking and other end-of-trip facilities are essential elements of a multimodal transportation system.*



SHELTERED BIKE PARKING IN ARLINGTON  
(PHOTO CREDIT: WMATA)

Lack of secure bicycle parking at home and at daily destinations is a common barrier to bicycling as a convenient, healthy, affordable, and environmentally friendly way to travel. Therefore, adequate bicycle parking should be available at residences, places of employment, schools and other destinations, as well as wherever car parking is provided. While the Fairfax County Zoning Ordinance (6102. Bicycle Parking Requirements) sets a minimum bike parking rate, this supplemental document defines the

desirable rate of short-term to long-term spaces, provides additional rack and facility design and location guidance, and recommends optional enhancements to improve user comfort. Planning for bicycle parking from the beginning of a project can make it possible to provide well-designed, convenient, secure, and accessible bicycle parking in a cost- and space-effective manner.

## 2: Key Bicycle Parking Principles

*All bicycle parking should adhere to these basic principles to ensure safety, security, and convenience:*

### Facility Type

Bicycle parking should be tailored to the needs and abilities of different users based on

- duration of visit (short or long term),
- demographics of expected users,
- types and sizes of bicycles, micromobility vehicles and other personal mobility aids (e.g., strollers or wheelchairs) likely to be stored, and
- available space on site (within or adjacent to physical structure).



*Long-term bicycle parking example*  
(PHOTO CREDIT: DERO)

### Quality

The design of bicycle racks should

- support the bicycle or micromobility vehicle at two points above its center of gravity,
- be intuitive for first-time users,
- accommodate high-security U-shaped locks,
- not contain protruding elements or sharp edges,
- not bend wheels or damage other parts of the parked bicycle,
- be located on a durable and dustless surface,
- be securely anchored and mounted on the surface, be anchored into the ground with tamper-resistant hardware, or be mounted to rails, which can then be anchored to the surface or free-standing,
- and follow appropriate installation procedures.

### Location

Bicycle parking should be located

- close to destinations or building main entrances (preferably within 25-50 feet),
- at ground level,
- along stair-free and comfortable bicycle routes and facilities, and
- in a visible and well-lit location.

### Access

Bicycle parking should

- be designed so that bicyclists can access the location without being required to dismount before arriving at the rack (i.e. not at the top of stairs),
- not create conflicts with pedestrians or motorized vehicles, and
- provide enough separation from adjacent racks and other vertical objects so that users can easily reach and use them.



*Example of bike rack that supports the bike frame in two places, and proper U lock application*  
(PHOTO CREDIT: DERO)



### 3: Basic Bike Parking Design Guidance

*When designing bicycle parking sites, consider the amount of space used by a fully occupied rack and the space needed for users to access the parking area and use both sides of the rack.*

#### Basic Bike Parking Space Requirements

- A standard bicycle parking space should be **eight feet in length and two feet in width.**
- Bicycle parking spaces that are designed to accommodate larger bicycles, cargo bicycles and bicycles with attachments should be **ten feet in length and at least two feet in width.**

**Figure 1.** Bicycle parking footprint: (left) standard adult bicycle parking area, eight feet by two feet; (right) cargo bicycle or bicycle with trailer parking area, ten feet by two feet.

ILLUSTRATION BASED ON APBP "ESSENTIALS OF BIKE PARKING", 2015

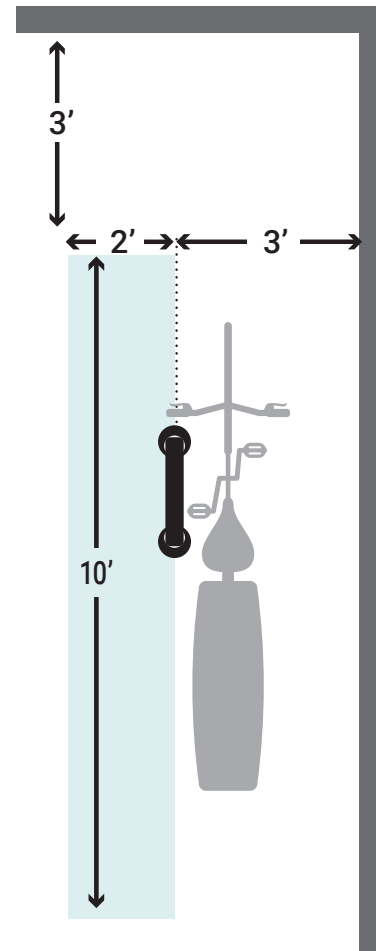
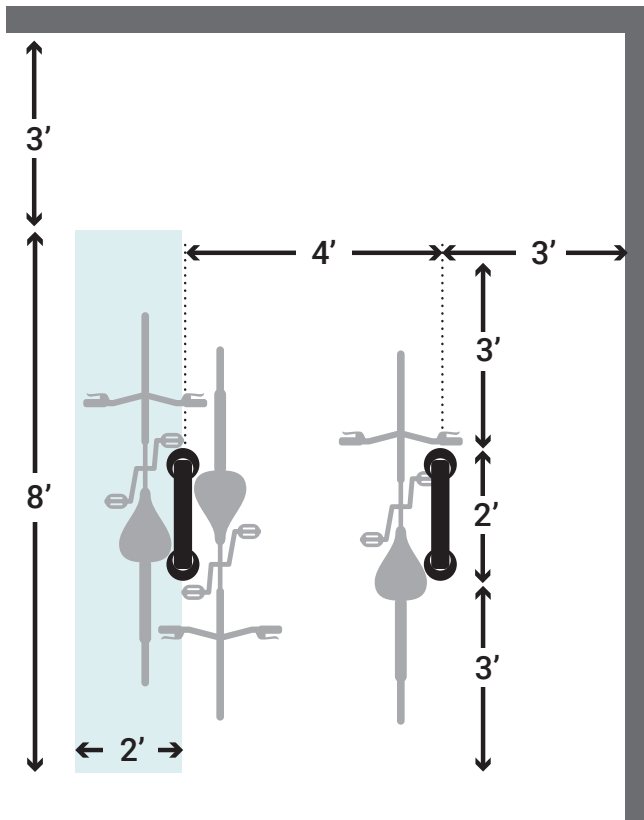

## Acceptable Rack Types

Inverted U racks support the parking of two standard or non-standard bicycles or micromobility vehicles simultaneously, one on each side of the rack. They may be installed in a series to create parking areas of variable quantities. Variations of the Inverted U rack design are acceptable as long as basic rack functions and security features are maintained. The tubing can be round, elliptical, or square. Mounting options include: in-ground, surface mount with base plate, and rail mounting.

**Figure 2.** Examples of common bicycle racks that are not acceptable, as they do not support the bicycle frame in at least two places when used as intended.



## Parking and Wayfinding Signage

Whenever possible, bicycle parking should be located within sight of the building entrances and any bicycle routes along and on the property. Directional signage should be provided if sight distance cannot be achieved. The example images to the right and below show the layout of the approved bicycle parking sign in the Manual on Uniform Traffic Control Devices for Streets and Highways (MUTCD) and a creative painted solution in a parking garage.



*Sign D4-3, Manual on Uniform Traffic Control Devices for Streets and Highways (MUTCD)*



*Inverted U rack example*  
(PHOTO CREDIT: DERO)



*Bike Wayfinding example*  
(PHOTO CREDIT: CASSELDEN)



## 4: Short-Term Bicycle Parking

*Short-term parking is designed to meet the needs of people visiting businesses and institutions, and others with similar needs—typically lasting up to two hours.*

Short-term parking should be easy to access, visible and intuitive to use for first-time users, and located close to the destination or primary entrance. Providing adequate and convenient short-term bicycle parking for visitors will discourage the use of trees, fences and railings for bicycle parking purposes and ensure that accessible routes and emergency access are not blocked by parked or tipped over bicycles and micromobility vehicles (see **Figure 3** on page 8). See **Chapter 6** (page 16) to determine recommended short-term bike parking rates by use.

### Location

The location of short-term bicycle parking should

- be easily and comfortably accessible by bike from the public street, sidewalk, trail or cycletrack (if applicable)
- be within 50 feet of main building entrances, preferably within 25 feet
- be placed in locations with high levels of pedestrian traffic and which are visible to passers-by and people entering buildings to promote use and enhance security
- be covered, if practical, where visitors may leave their bicycles or micromobility vehicles for more than just a few minutes (e.g., a school)
- allow reasonable clearance for opening of doors of parked cars, especially near designated accessible parking



*Short-term bike parking example*  
(PHOTO CREDIT: TAMPA DOWNTOWN PARTNERSHIP)



*Short-term bike parking example*

- not impede on any adjacent pedestrian facility (this holds true for short-term bicycle parking that is both occupied by a bicycle or micromobility vehicle or empty)
- not impede routine maintenance activities or service access
- not block pedestrian access to buildings, bus boarding, or freight loading
- provide racks spaced four feet apart – a minimum distance of three feet is acceptable in constrained conditions
- be placed at least three feet from signposts, light poles, manholes, trees, and other street furniture
- be a minimum distance of ten feet from any fire hydrant or fire hose connection
- obtain any necessary permits from Virginia Department of Transportation (VDOT) if placed in the VDOT-maintained right-of-way

## Access

The access route to the short-term parking area should

- be easily navigated by common bicycles and bicycle accessories (obstructions to access include objects, motor vehicle spaces, and loading areas)
- be fully separated from vehicular traffic
- have no stairs or steep ramps (greater than five percent)
- be well-lit and utilize fixtures that shield the light source to minimize light pollution, reduce glare, facilitate better vision at night, and conserve energy



*Short-term bike parking on permeable pavers example*  
(PHOTO CREDIT: ANTHONY TERREBONNE)

## Rack Types

**Basic requirements:** Short-term bicycle parking should adhere to the Basic Bicycle Parking Principles outlined above. The preferred type of short-term bicycle parking is the inverted U bicycle rack.





**Figure 3.** Bike Parking Site Planning for Inverted U Bicycle Racks

ILLUSTRATION BASED ON APBP "ESSENTIALS OF BIKE PARKING", 2015

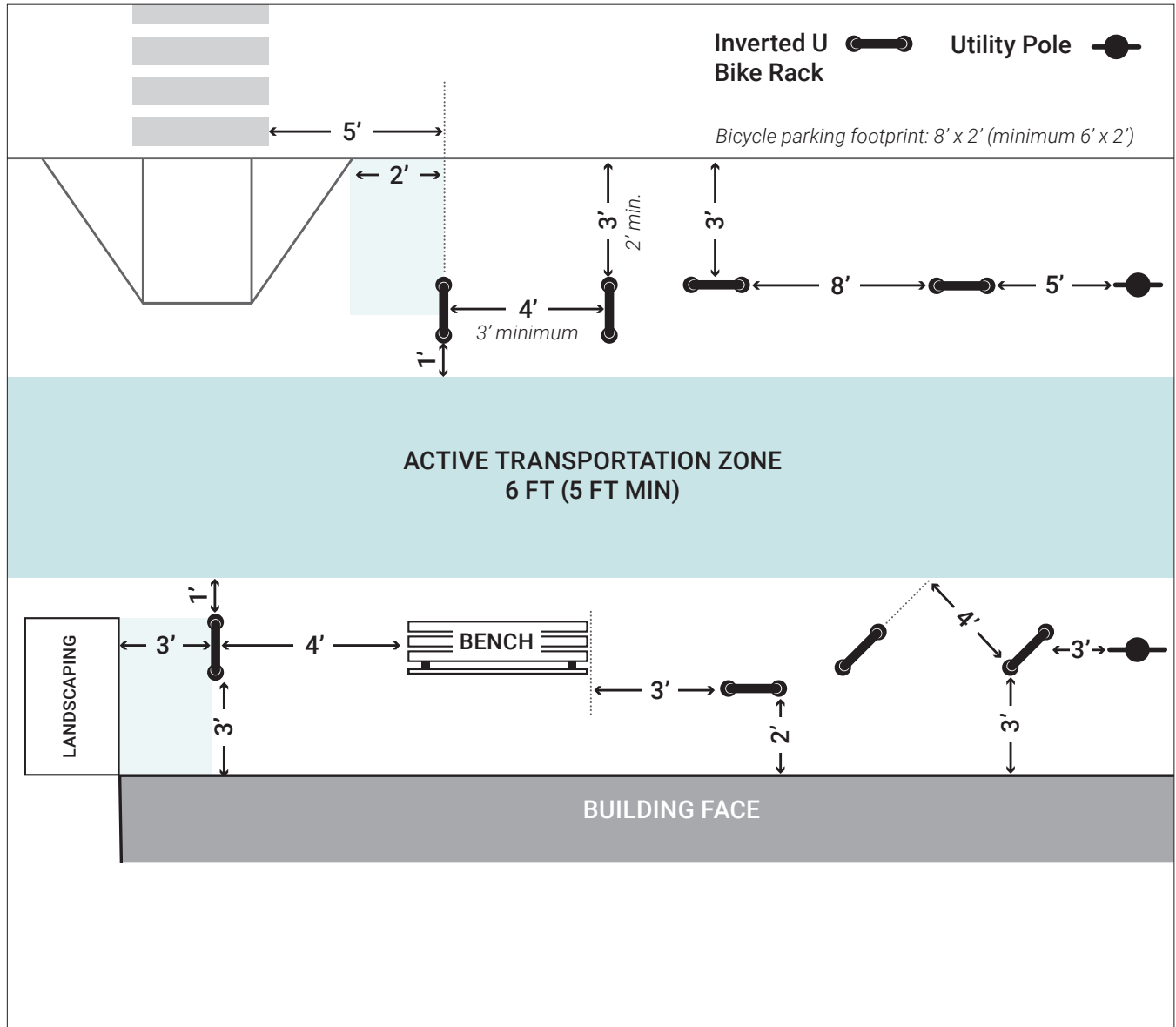

## Additional Equipment and Design Options

In addition to meeting the basic bicycle parking guidelines, location specifications and rack design recommendations outlined above, the following design solutions are also recommended amenities:

- Bicycle parking on permeable pavement to allow stormwater to quickly infiltrate through the surface.
- Bicycle racks with integrated locks or alarms provide additional theft security.
- Bicycle racks with integrated power outlets allow users of electric bicycles and micromobility vehicles to charge their vehicle batteries while not in use (solar-powered or hard-wired).
- Shelter from the weather can be provided by integrating a cover into the overall rack design, by providing a stand-alone shelter for a set of racks, or by locating racks under trees, a structure or building overhang.
- Artistically inspired racks can be used to combine functional bicycle parking, public art and placemaking, but should be designed in accordance with the design and location guidelines described above. With some artistically inspired racks it may be necessary to identify them as bicycle racks through additional signage, so that potential users understand they are not simply public art.
- Bicycle racks placed in a car parking space—bicycle corrals—on a street or parking lot should address the following:
  - » Protect parked bicycles and micromobility vehicles from motor vehicle encroachment by placing flexible delineators, wheelstops, planters or other vertical barriers between the bicycle racks and adjacent motor vehicle parking spaces and travel lanes as needed.



*Bike shelter example*

(PHOTO CREDIT: DUO-GUARD)

- » The bicycle parking spaces should be flush with the adjacent travel lane or accessible via a mountable curb.
- » Bicycle racks can be placed on streets with an average of 3,000 vehicles per day or less.
- » On higher volume streets, bicycle racks should be installed adjacent to bike lanes.
- » A clear space of two feet should be provided between the bicycles parked in the bicycle corral and an adjacent travel lane (see **Figure 4**).

### **Area-specific rack design guidelines and standards:**

Note that several areas within Fairfax County have detailed design guidelines that provide guidance on the type, material and color of bicycle racks, to ensure compatibility to the street furnishings selected for that specific area. See the Fairfax County Comprehensive Plan Special Area Plans for guidance.



## Markings

Micromobility parking can also be designated through pavement markings. Designating scooter parking zones, for example, can be especially helpful to organize and promote shared micromobility parking. The recommended footprint is six feet by twelve feet but can be adapted to different sizes. Zones located in public right-of-way must be approved by VDOT.

Bike corrals can create a sense of place and invite use by adding a street mural within the parking area. Bike corrals and street murals located in public right-of-way must be approved by VDOT.



*Scooter parking example*  
(PHOTO CREDIT: CITY OF MINNEAPOLIS, MN)



*Example of a bike corral with street mural*  
(PHOTO CREDIT: SFMTA)

**Figure 4.** Bicycle Corrals

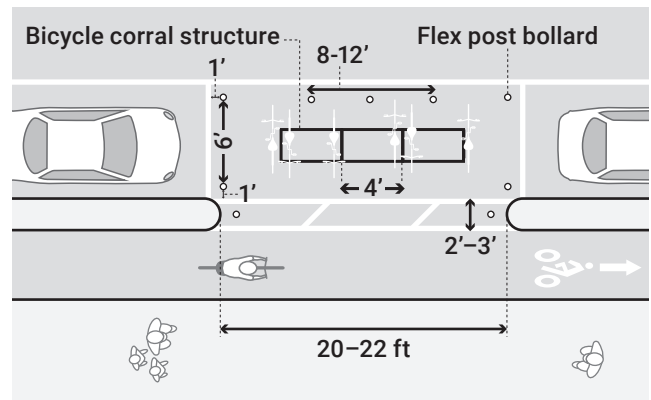

## Maintenance

Basic maintenance of provided short-term bicycle racks will maintain the functionality of the amenity and ensure continued compliance with the Fairfax County Zoning Ordinance.

- Property managers should periodically remove locks, debris, dust and dirt from the bike parking rack and surrounding surfaces.
- Property managers should periodically identify and remove abandoned bicycles to ensure bicycle parking spaces remain available for other users.
- Property managers should repaint, recoat, or replace bike racks if rusty or damaged.

## 5: Long-Term Bicycle Parking

*Long-term bicycle parking is intended for employees at their place of employment, transit users and residents of multi-family dwellings, and guests or visitors where the duration of parking is typically over several hours.*

Signage should be used to inform bicyclists how to become a user of the secure bicycle parking area or facility, or information should be provided through newsletters, on-boarding or new resident information packages, and/or on the applicable website. See **Chapter 6** to determine recommended long-term bike parking ratios by use.

### Type of Facilities

**Bicycle Rooms** are controlled-access bicycle storage facilities in a building or garage (see **Figure 5**). Larger buildings often offer multiple bike rooms. The walls of the bike room can be solid or floor-to-ceiling fencing that is thick enough to deter bolt cutters and angle grinders.

**Bicycle Cages** are freestanding, covered, controlled-access facilities that can range in size from low profile sheds that can fit into a parking space to full-height shelters with floor to roof fencing. These facilities are a good choice for residential or commercial buildings that do not have suitable interior space for a secure bicycle parking area, as well as smaller transit stations and commuter park and ride lots. Bicycle cages should complement the aesthetic character of the site.

**Bicycle Lockers** are self-contained units that only serve one user at a time and can securely store related accessories. They provide a high level of security and can be located outdoors or indoors. However, bicycle lockers cannot store non-standard bicycles such as cargo bicycles, recumbent bicycles, tricycles and taller bicycles. Bicycle lockers are anchored to the ground and are constructed of durable, tamper-resistant materials such as steel, aluminum, or fiberglass-reinforced plastic.



*Bike Room example*  
(PHOTO CREDIT: STUDIO 618)



*Bike Cage example*  
(PHOTO CREDIT: RTD DENVER)



*Bike Locker example*  
(PHOTO CREDIT: SAN JOSE PUBLIC LIBRARY)



## Location

The location of long-term bicycle parking should

- be in a secure and weather protected location fully separated from vehicle parking
- be as convenient—or more convenient—than the closest motorized vehicle parking
- be located inside or directly adjacent to the same building as the users it is intended to serve
- be immediately adjacent to and at-grade with the nearest bicycle facility, but no further than 100 feet from a primary entrance, as measured by walking distance
- be well-lit, clean, easy to move and maneuver a bicycle within

## Access

The access route to the long-term parking area should

- be easily navigated with common bicycles and bicycle accessories. Impermissible obstructions include objects, motor vehicle spaces, and loading areas
- be fully separated from vehicular traffic, including inside parking garages
- have no stairs, steep ramps, or small elevators. Ramps should have a slope equal to or less than five percent. Elevators used to access the secure bicycle parking area should be at least 6 feet 8 inches long and 4 feet 6 inches wide.
- be well-lit
- include wayfinding from the property and main entrances to inform users of the location of the facility
- be at least six feet wide, with no more than two doors or other constriction points that are narrower than three feet wide and extend more than one foot of distance
- ensure that any doors are manufactured to meet accessibility requirements and guidelines



*Bike Room rack layout example*  
(PHOTO CREDIT: HUNTCO)

## Equipment

### Bike Room and Bicycle Cage Rack Recommendations

- Long-term bicycle parking should adhere to the Basic Bicycle Parking Principles and Basic Bicycle Parking Design Guidelines outlined above.
- The most user-friendly and versatile rack type for long-term bicycle parking facilities are floor-mounted inverted U type racks to accommodate standard and non-standard bicycles, micromobility vehicles, and users that cannot lift their bicycle.
- A minimum of approximately 30 percent of total long-term bicycle parking capacity should provide an integrated power outlet or be co-located with a separate power outlet (one per parking space) to allow users to charge electric bicycles, scooters and other micromobility vehicles.
- At least 10 percent of capacity should accommodate larger bicycles, cargo bicycles and bicycles with attachments to allow wider and/or longer bicycles such as adult tricycles, recumbents, cargo bicycles and bicycles with infant seats, and bicycles with attachments such as trailers and trailer bicycles (see **Figure 1** for dimensions) to be securely parked.

**TIP:** *Some bicycle rack vendors offer free room layout services.*

**Figure 5.** Site Planning Dimensions for a Bike Room

ILLUSTRATION BASED ON APBP "ESSENTIALS OF BIKE PARKING", 2015

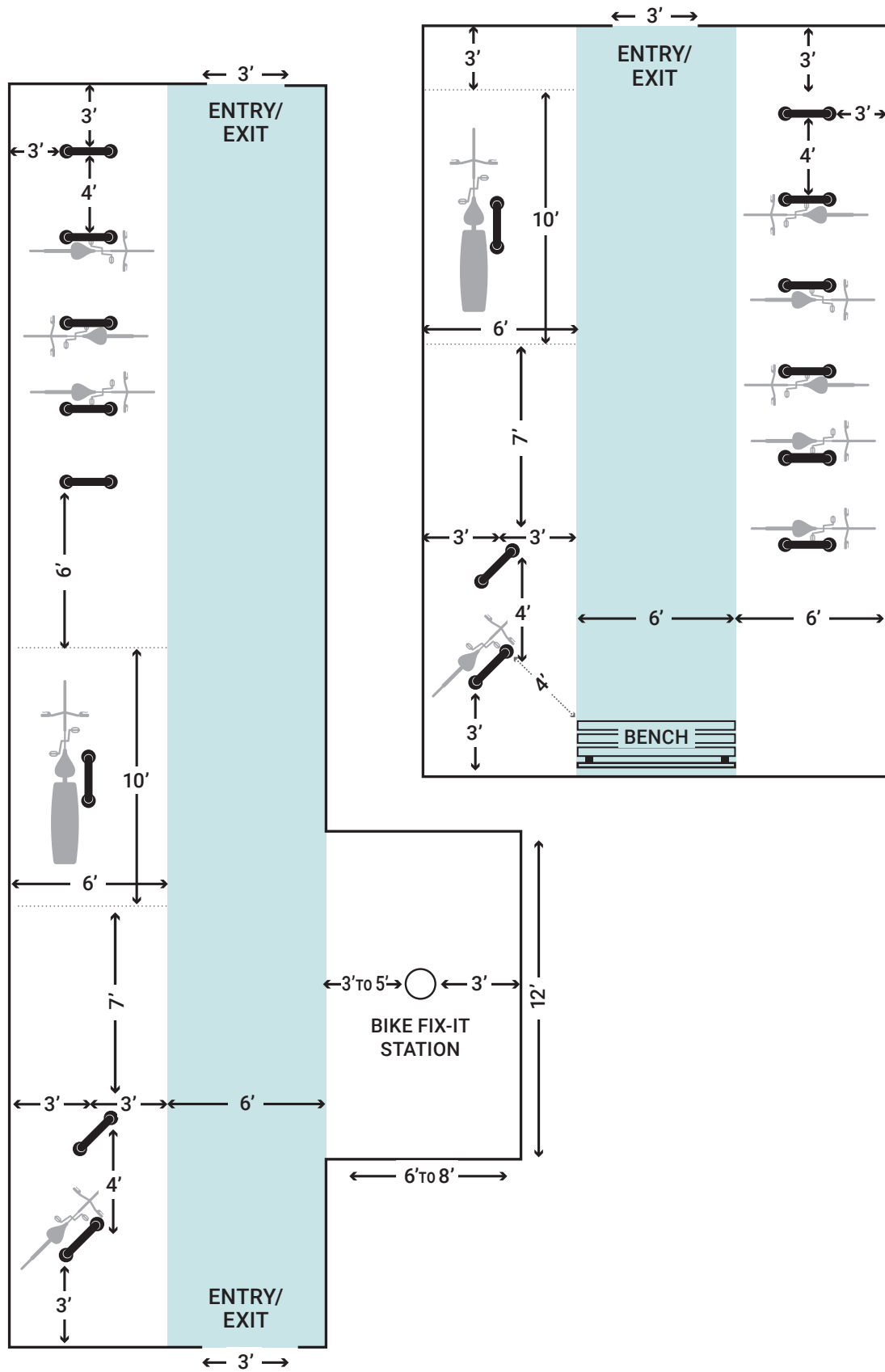



*Bike room with controlled access*

## Security Recommendations

- Access-control is essential to increase security and safety by limiting entry to the bicycle storage facilities. An access-controlled parking garage does not provide sufficient security and an additional layer of access-control should be provided for the secure bicycle storage area.
- Long-term bicycle facilities should be well-lit, well-maintained, and located in highly visible locations to ensure personal safety of users and to deter theft.
- Use architectural fencing, glazing, or other open design treatments to increase visibility.
- Fencing or other containment should run floor to ceiling.
- If gaps are unavoidable, they should be less than eight inches.
- Install call boxes.
- Use security cameras to monitor the secure area.

## Recommended Additional User Amenities

The following amenities are optional but recommended practice to improve comfort, convenience and usability of long-term bicycle parking. These could include, but are not limited to:

- Bicycle repair stations or tools
- Scooter racks or designated scooter parking areas
- Community message boards
- Informational signage (e.g., bicycle theft prevention best practices, bike laws)
- Lock holders
- Lockers to store equipment
- Restrooms and showers
- Changing areas
- Mirrors
- Colorful walls and/or floor, or bicycle-themed mural, sculptures or other art

## Bike Room Maintenance

Basic maintenance of provided long-term bicycle parking facilities will maintain the functionality of the space and ensure continued compliance with the Fairfax County Zoning Ordinance.

- Bike rooms cannot be converted into storage space.
- Property managers should quickly provide access to bike rooms upon request.
- Property managers should repaint, recoat, or replace bike racks if rusty or damaged.



*Bike rack with integrated outlet*  
(PHOTO CREDIT: DERO)

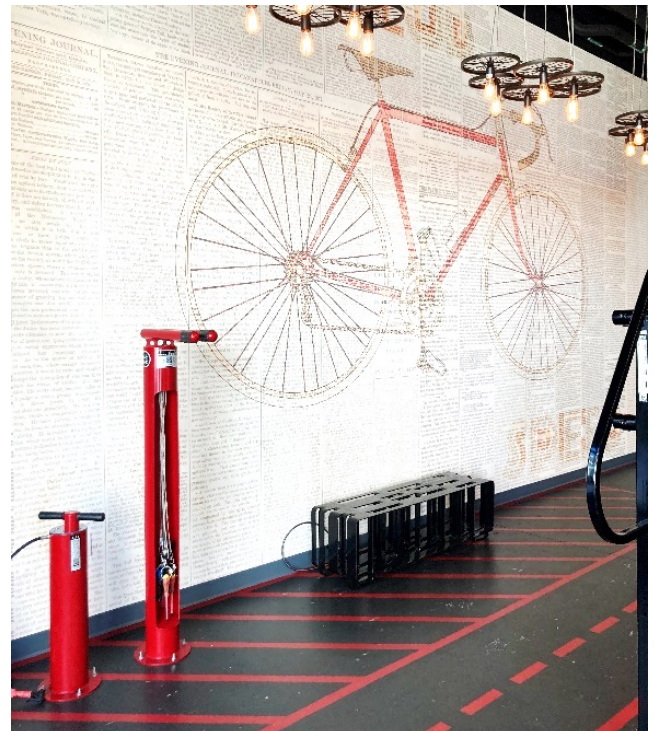

*Repair stands, bench, and art in a bike room*





# 6: Recommended Short-Term and Long-Term Bicycle Parking Ratio

*While the Fairfax County Zoning Ordinance (6102. Bicycle Parking Requirements) sets a minimum bike parking rate, this supplemental document defines the desirable ratio of short-term to long-term spaces by land use.*

**Table 1.** Recommended Short-Term and Long-Term Bicycle Parking Ratio

Use	Recommended Ratio
<b>Agricultural and Related Uses</b>	
Agricultural and Related Uses	100% Short-Term
<b>Residential Uses</b>	
Dwelling, Multifamily	10% Short-Term and 90% Long-Term
Residence Hall	
All other Residential Uses	N/A
<b>Public, Institutional, and Community Uses</b>	
Club, Service Organization, or Community Center	80% Short-Term and 20% Long-Term
College or University	
Community Swim, Tennis, and Recreation Club	
Cultural Facility or Museum	
Congregate Living Facility	20% Short-Term and 80% Long-Term
Independent Living Facility	
Medical Care Facility	70% Short-Term and 30% Long-Term
Public Use	
Religious Assembly	
Religious Assembly with Private School, Specialized Instruction Center, or Child Care Center	
Specialized Instruction Center	
School, Private	
All other Public, Institutional, and Community Uses	
Public Use; Transit	50% Short-Term and 50% Long-Term

**Table 1.** Recommended Short-Term and Long-Term Bicycle Parking Ratio (*continued*)

Use	Recommended Ratio
<b>Commercial Uses</b>	
Commercial Recreation, Indoors	90% Short-Term and 10% Long-Term
Commercial Recreation, Outdoors	
Restaurant	
Restaurant, Carryout	
Retreat Center	
Retail Sales, General	
Retail Sales, Large	
Shopping Center	
Stadium	
All Other Commercial Uses	
Quasi-Public Park, Playground, or Athletic Field	100% Short-Term
Hotel or Motel	30% Short-Term and 70% Long-Term
Office	20% Short-Term and 80% Long-Term
<b>Industrial Uses</b>	
Industrial Uses	20% Short-Term and 80% Long-Term



*Fairfax County Department of Transportation (FCDOT) ensures nondiscrimination in all programs and activities in accordance with Title VI of the Civil Rights Act of 1964 and the Americans with Disabilities Act (ADA). To request this information in an alternate format, contact FCDOT at 703-877-5600, TTY 711.*