



FAIRFAX COUNTY PARK AUTHORITY



M E M O R A N D U M

TO: Chairman and Members
Park Authority Board

VIA: Kirk W. Kincannon, Executive Director

FROM: Todd Brown, Director
Park Operations Division

DATE: March 2, 2017

Agenda

Park Operations Committee
Wednesday, March 8, 2017 – 6:15 p.m.
Boardroom – Herrity Building
Chairman: Linwood Gorham
Vice Chair: Michael Thompson, Jr.
Members: Mary Cortina, Frank Vajda, Faisal Khan

1. Approval – Jones Branch Park and Arbor Row Stream Valley – Naming of Park Honoring Ken Lawrence – Action*
2. Eakin Park – Mastenbrook Volunteer Matching Fund Grant Program Request – Eakin Trust – Action*

*Enclosures



If accommodations and/or alternative formats are needed, please call (703) 324-8563. TTY (703) 803-3354

This page intentionally left blank.

Board Agenda Item
March 22, 2017

ACTION

Approval – Jones Branch Park and Arbor Row Stream Valley – Naming of Park Honoring Ken Lawrence (Providence District)

ISSUE:

Naming of Jones Branch Fields and restored Arbor Row Stream Valley Park in honor of Ken Lawrence, a longtime advocate for parks, fields and open space in Fairfax County and a major influence in getting the park recommendations for the fields and stream valley into the Tysons Urban Center Comprehensive Plan.

RECOMMENDATION:

The Park Authority Director recommends approval of the naming of Jones Branch Fields and restored Arbor Row Stream Valley Park in honor of Ken Lawrence.

TIMING:

Board action is requested on March 22, 2017, to be ready in time for a public ceremony which will be scheduled between now and the end of the summer.

BACKGROUND:

The Jones Branch Fields and restored Arbor Row Stream Valley Park represent two initial park project completions within the Tysons Urban Center planned area. Both have proven very popular and the Jones Branch Road Fields are readily visible from well-traveled Jones Branch Road. The successful completion of these two projects was largely due to the efforts of former Providence District Planning Commissioner Ken Lawrence who passed away in December 2016. Commissioner Lawrence was a longtime advocate for parks, fields and open space in Fairfax County and was a major influence in getting these into the Tysons Plan. He believed that the denser the built environment, the greater the need for green space and outdoor recreation. He worked closely with the Park Authority, other Planning Commission members and Supervisor Linda Smyth and other Supervisors toward achieving these ends.

In honor of Commissioner Lawrence and his dedication to green space and outdoor recreation in Fairfax County and efforts to achieve such in the redeveloping Tysons area it is believed most appropriate to rename Jones Branch Fields and Arbor Row Park to Ken Lawrence Park.

Board Agenda Item
March 22, 2017

FISCAL IMPACT:
None

ATTACHMENT:
Attachment 1: Map of Jones Branch Fields and Arbor Row Stream Valley Park

STAFF:
Kirk W. Kincannon, Executive Director
Sara Baldwin, Deputy Director/COO
Aimee L. Vosper, Deputy Director/CBD
Todd Brown, Director, Park Operations Division
Judy Pedersen, Public Information Officer
Andrea Dorlester, Manager, Park Planning Branch, Planning and Development Division

Jones Branch Fields

Arbor Row Stream Valley

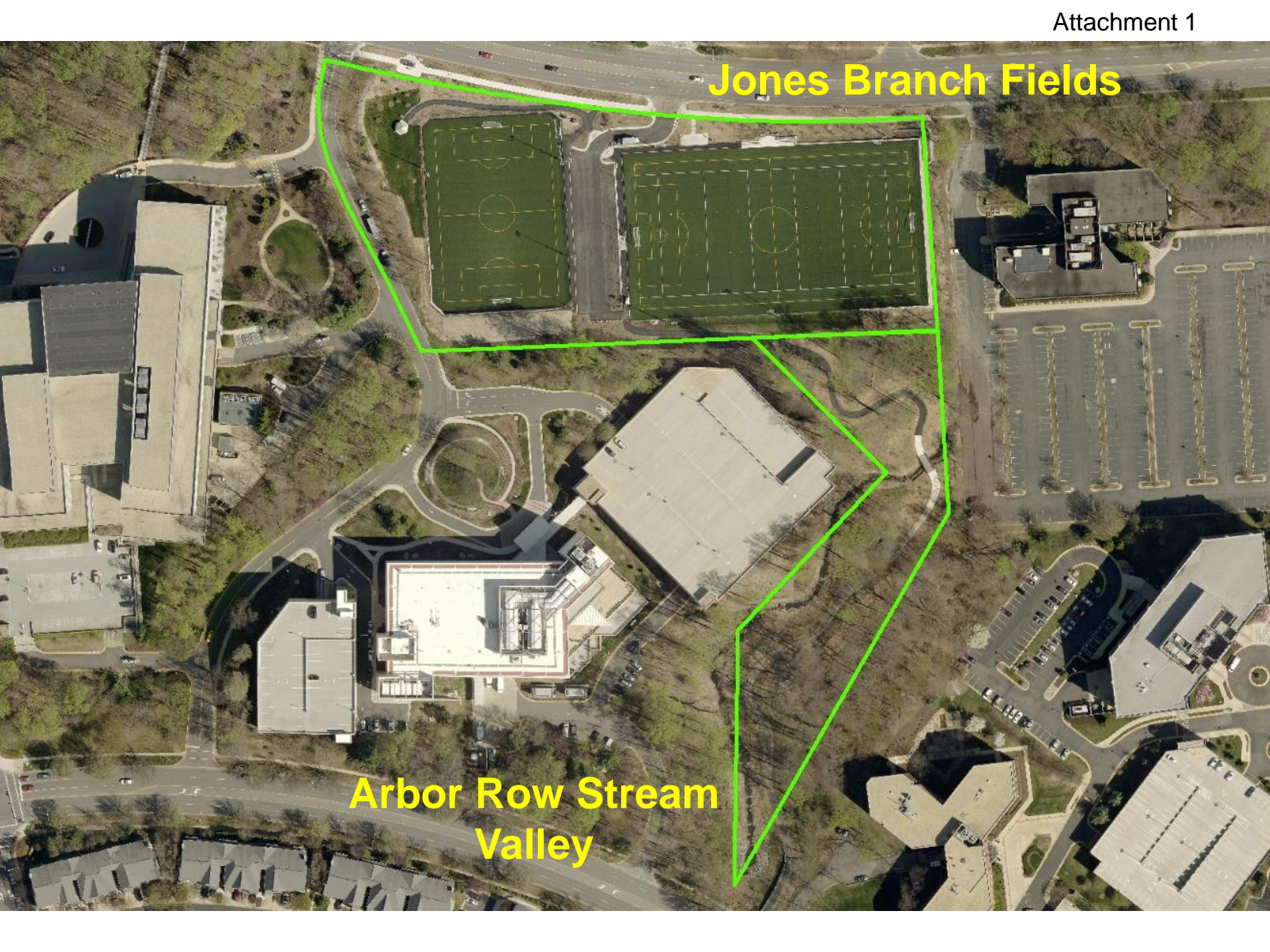

This page intentionally left blank.

Board Agenda Item
March 22, 2017

ACTION

Eakin Community Park – Mastenbrook Volunteer Matching Fund Grant Program Request – Eakin Park Family Trust (Providence District)

ISSUE:

Approval of a Mastenbrook Volunteer Matching Fund Grant Program request from the Eakin Park Family Trust in the amount of \$20,000 to construct a picnic shelter at Eakin Community Park.

RECOMMENDATION:

The Park Authority Director recommends approval of the Mastenbrook Volunteer Matching Fund Grant Program request from the Eakin Park Family Trust in the amount of \$20,000 to construct a picnic shelter at Eakin Community Park.

TIMING:

Board action is requested on March 22, 2017, in order to award the grant.

BACKGROUND:

The Eakin Park Family Trust (EPFT) is requesting to construct a 20' x 24' picnic shelter at Eakin Community Park (Attachment 1). Eakin Community Park is a small community park located off of Tobin Road, and currently has ball diamonds, tennis courts, volleyball courts, garden plots, the Gerry Connolly Cross County Trail, and a parking lot located within it. EPFT is looking to benefit several communities that are near to the park by providing an outdoor space to meet, eat, and relax. The shelter will be ADA compliant, and will include four tables and a grill. It will be available on a first come first serve basis, and will be evaluated by Park Services for possible inclusion in the picnic rental program.

EPFT is requesting \$20,000 from the Mastenbrook Volunteer Matching Fund Grants Program to help fund the completion of the project (Attachment 2). If approved, the \$20,000 from the Mastenbrook Volunteer Matching Fund Grants Program, along with a \$69,795.15 contribution from the EPFT, will provide the funds sufficient to complete the project. The total project budget is \$89,795.15.

The Eakin Park Family Trust was established in 1951 at the same time that Leroy Eakin, Sr. donated the initial 14 ½ acres of land to the Park Authority. The trust was

Board Agenda Item
March 22, 2017

established to help make future improvements to the park. In subsequent years, an additional 90 acres of land was donated by Mr. Eakin.

The Park Authority Board Member for the Providence District supports approval of the Grant request. Staff from Planning and Development will manage the project, which is scheduled for completion by the summer of 2017. Matching funds are available to complete this project.

FISCAL IMPACT:

The estimated total project cost is \$89,795.15. Funds are currently available in the amount of \$20,000 in WBS PR-000009, Community Parks/New Facilities-2012, in Fund 300-C30400, Park Authority Bond Construction; and \$69,795.15 from EPFT, resulting in the total available funding of \$89,795.15.

Contingent on the approval of this project, the remaining balance in the Mastenbrook Volunteer Matching Fund Grant Program will be \$106,562.61.

ENCLOSED DOCUMENTS:

Attachment 1: Aerial Showing Grant Project Area at Eakin Community Park

Attachment 2: Mastenbrook Volunteer Matching Fund Grant Program Request – Eakin Park Family Trust

STAFF:

Kirk W. Kincannon, Executive Director

Aimee L. Vosper, Deputy Director/CBD

Sara Baldwin, Deputy Director/COO

Todd Brown, Director, Park Operations Division

Barbara Nugent, Director, Park Services Division

Dan Sutherland, Manager, Park Management Branch, Park Operations Division

Janet Burns, Senior Fiscal Manager

Michael P. Baird, Manager, Capital and Fiscal Services

Eakin Community Park

Project Area





Mastenbrook Volunteer Matching Fund Grants Program Application Form

PLEASE PRINT. Please provide all information requested. You may attach additional sheets and/or materials to support your request.

1. Grantee Information

Name of Individual or Organization: Eakin Park Family Trust c/o Eakin Properties

Contact Person: Timothy Eakin Walsh

Mailing Address: 106 S. Roosevelt Street, Falls Church, VA 22042-2430

Phone: (703) 447-2236

Fax: (877) 731-9907

2. Project

Title: Eakin Community Park Shelter

3. Funding Requested

Amount \$ 20,000.00

(Applicant may request more than one project per fiscal year, the combined total not to exceed \$20,000.)

4. Project Description

Provide a description of your project. (Attach drawings or specification of *materials* proposed for purchase. If *educational materials* are proposed, provide a mock up or example of how the product will look, how it will be posted or distributed, and an example of the content. Provide a detailed map and other visual materials, site plan, drawings, photos, cross sections or a mock up of your project and what the finished product will look like.) Provide as much detail as you can to help evaluators clearly understand your project.

In June 2016, the Eakin Park Family Trust contributed \$ 69,795.15 to the Fairfax County Park Foundation for the installation of a 20 foot by 24 foot picnic shelter at Eakin Community Park. The shelter will be located near the tennis courts at the Tobin Road entrance. See the attached drawings for the design of the shelter.

The ADA accessible shelter project will also include 4 picnic tables, one grill, and 2 trash receptacles. Funding for these items will be provided by the Fairfax County Park Foundation.

5. Public Benefits

Explain why your project is important and why it is needed? Who are the intended users? How will the public benefit? How many and what different types of users do you expect? How does this project provide new recreational opportunities for the intended users? Does your project solve a problem or provide important missing services? If your project provides for people with disabilities, in what way?

The new picnic shelter will fulfill the community building strategy for the Fairfax Planning District as stated on page 12 of the Great Parks Great Communities document dated May 2011.

The picnic shelter will benefit the residents of Prosperity Heights, Strathmead Square, Woodburn, Woodburn Village, the Court of Camelot, and Pine Ridge communities by having an outdoor community meeting space. In addition, the users of the nearby volleyball courts, baseball fields, garden plots, and cross county trail will have an ADA accessible picnic shelter to use.

The shelter will be available to all park users at no-cost on a first come first served basis from dawn until dusk, 365 days a year. The communities can gather without having to pay a reservation fee.

The shelter will be ADA accessible, and include a 30-foot walkway leading to two ADA parking spaces.

6. Sponsor Commitment

What experience do you or the organization have in accomplishing similar projects? Who will be responsible for organizing and assigning the work to insure successful project completion? You will need to document all project expenditures. What is your plan for documenting the work photographs, video, written documentation, etc.)? What is your plan, if any, for long-term maintenance of your project after it is completed?

The Eakin family's Foundation has previously contributed to other Park Authority projects and has already contributed funding for the community picnic shelter. The donor's representative has talked with the Planning and Development Division to ensure the shelter will be built according to FCPA & ADA standards and requirements. The Planning & development Department has secured plans and a detailed budget. Photographs and video of the work in progress will be taken throughout the building process. As long as the shelter is being used the Park Operations staff will provide for routine maintenance.

7. Proposed Budget

You will need to provide a detailed and complete budget. Provide enough detail for evaluators to understand exactly what grant funds will be used for, how you arrived at the prices for services, labor, materials, equipment, etc., and the same level of detail about the amount and source of matching funds.

The Park Authority prefers to reimburse grantees after the work is completed. Please check one of the following:

- We understand payment by the Park Authority will occur after we complete the project.
 We must have Park Authority grant funds prior to beginning the project.

See the attached budget for the picnic shelter.



Signature of Timothy Eakin Walsh

2/7/2017
Date

Community Park Picnic Shelter 1-20-15 - Construction Cost Estimate

Near Tobin Road Entrance

Furnish and Install New Shelter - 20' x 30'



A-6 Attachment

F
C
P
A

DESCRIPTION	QTY	UNIT	UNIT COST	
MOBILIZATION				\$3,900.00
General Conditions	1	EA	\$1,000.00	\$1,000.00
Mobilization	1	EA	\$500.00	\$500.00
Clean-Up, seed and straw	1	EA	\$400.00	\$400.00
20 CY dumpster incl dump fee	1	EA	\$700.00	\$700.00
Locate private utilities fee	1	EA	\$600.00	\$600.00
Permit Preparation and submittal (fees by FCPA)	1	EA	\$700.00	\$700.00
EROSION CONTROL				\$1,000.00
Silt fence	200	LF	\$5.00	\$1,000.00
EXCAVATION & EARTHWORK				\$3,500.00
Site Excavation 23 CY and disposal	1	LS	\$3,500.00	\$3,500.00
CONCRETE FOUNDATION & COLUMN FOOTINGS				\$5,856.00
Slab - Aggregate Material #57 Stone 6" Depth delivered & placed	78	SY	\$12.00	\$936.00
Concrete slab with turndown(4" w/ #4, 4"WWF)	78	SY	\$40.00	\$3,120.00
Footings - 3500 psi with #4 rebar	8	EA	\$300.00	\$2,800.00
STEEL STRUCTURE				\$40,600.00
20'x30' Structure Only SLF-G2030-04 w/options (pwr coat, finish, mtg roof)	1	EA	\$22,500.00	\$22,500.00
Add cost for underside roof decking and specialty fascia	1	EA	\$2,100.00	\$2,100.00
Cost for certified drawings	1	EA	\$1,000.00	\$1,000.00
Installation	1	EA	\$15,000.00	\$15,000.00
ACCESSIBLE WALKWAY				\$5,200.00
8' conc Sidewalk - Existing Trail to Shelter	30	LF	\$40.00	\$1,200.00
Ada parking spaces	2	EA	\$2,000.00	\$4,000.00
Subtotal				\$60,056.00
Contractor Overhead 10%				\$6,005.60
Contractor Profit 10%				\$6,005.60
Performance Bond 2%				\$1,201.12
Construction Subtotal				\$73,268.32
FURNISHINGS				\$7,700.00
Picnic Tables	8	EA	\$700.00	\$5,600.00
Grill ADA accessible	1	EA	\$1,500.00	\$1,500.00
Trash receptacles	2	EA	\$300.00	\$600.00
PERMITS & FEES COSTS				\$16,153.86
Testing and Inspection	1	EA	\$1,000.00	\$1,000.00
Contingency (10%) <i>Reimbursable to Eakin Trust if not utilized</i>	1	EA	\$7,326.83	\$7,326.83
Permits and Fees	1	EA	\$900.00	\$900.00
Administration (10%)	1	EA	\$7,326.83	\$7,326.83
ESTIMATE				\$104,821.98

Prospective Funding Partners

Eakin Family Trust	\$69,795.15
Mastenbrook Grant - Approval by PAB	\$20,000.00
FCPA - Administration	\$7,326.83
FCPF Request - Site Furnishings	\$7,700.00
Total	\$104,821.98

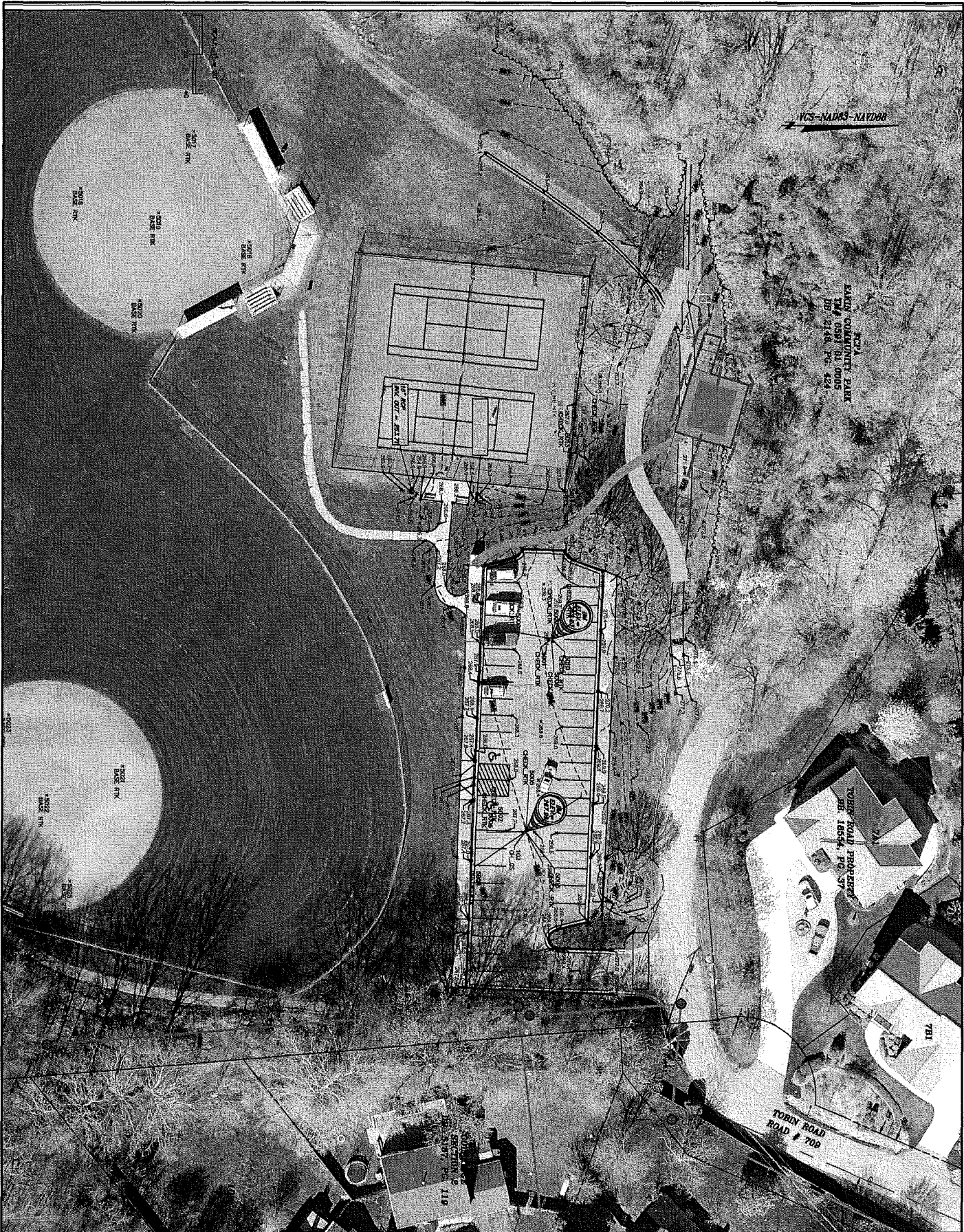

VCS-NA063-NAV208

NO. 21
 FAIRFAX COUNTY PARK
 TAX MAP 0101 01 0005
 DP 2148 PG. 424

TOURNAMENT PROPERTIES
 DP 10554 PG. 37

TOURNAMENT ROAD # 709

TOURNAMENT PROPERTIES
 DP 10554 PG. 37

STRATTON WOODS
 SHOWING EXISTING CONDITIONS
 HUNTER MILL DISTRICT
 FAIRFAX COUNTY, VIRGINIA



FAIRFAX COUNTY PARK AUTHORITY
 12055 Government Center Parkway
 Suite 406
 Fairfax, VA 22035-1118

DATE: 10-13-2009
 DRAWN BY: JOE FROVAY
 WORK ORDER: FT13-17
 TAX MAP: 0101 01 34
 SCALE: 1" = 100'
 SHEET: 1 OF 1

Material Specifications and Notes:

1. All structural steel tubing shall be ASTM A-500 Grade B-C
2. All other steel (plates, gussets, etc.) shall be ASTM A-36.
3. All welding is to be done in accordance with the latest AWS standards.
4. Standard bolts to be ASTM A-325 & threaded rod to be ASTM B-7 unless otherwise noted.
5. All fabricated steel & structural tubes are blasted to a near-white condition prior to application of primer and top coat.
 - Primer: Zinc Rich
 - Top coat: TGIC powder coating
6. Metal roofing shall be pre-cut 24ga. x 1 1/4" dp x 36" wide, Fy =50ksi steel panels.

Erection Notes:

All members must be properly braced until the complete structural system has been constructed. Bracing material and method is the responsibility of the G.C.

This building has been designed as a free standing, open structure. If walls or other modifications are to be made, the structure must be re-engineered prior to these modifications.

This document contains proprietary information and is not to be reproduced without the written permission from SUPERIOR RECREATIONAL PRODUCTS and/or is not to be used in any manner detrimental to the interest of SUPERIOR RECREATIONAL PRODUCTS.

N.I.C. = NOT IN CONTRACT
G.C. = GENERAL CONTRACTOR

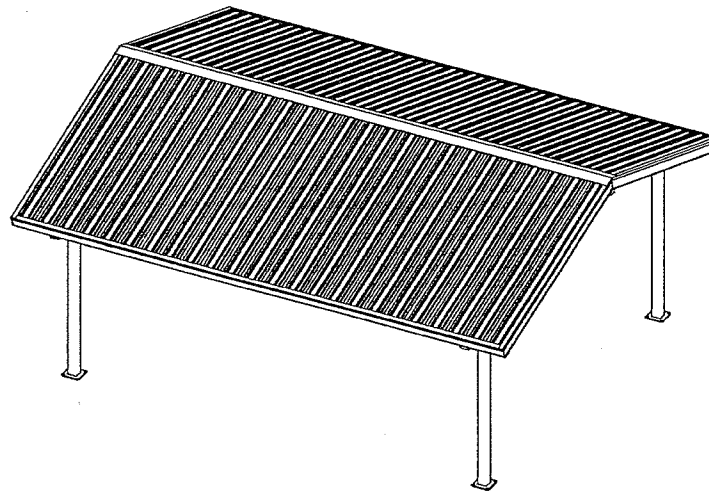

Table of Contents	
Page #	Description
1	General Specs and Notes
2	Primary Structural Views
3	Ground Plan Layout
4	Footer/Anchor Illustration

Model #: GE2024-AS

20'-0" x 24'-0" Gable End Shelter
7'-6" Eave Height
4:12 Pitch

Preliminary Drawings

All quotation drawings are preliminary only, not to be used for installation of any kind.

 SUPERIOR <small>RECREATIONAL PRODUCTS</small>	Rev Date & Description:		Superior Recreational Products <small>THIS DOCUMENT AND THE INFORMATION CONTAINED HEREIN IS THE EXCLUSIVE PROPERTY OF SUPERIOR RECREATIONAL PRODUCTS AND HAS BEEN PROVIDED TO YOU IN CONFIDENCE. THIS DOCUMENT AND THE INFORMATION HEREIN MAY NOT BE DISCLOSED OR PROVIDED TO ANY THIRD PARTY OR USED, COPIED, PHOTOGRAPHED OR OTHERWISE REPRODUCED WITHOUT PRIOR EXPRESS WRITTEN PERMISSION OF SUPERIOR RECREATIONAL PRODUCTS.</small>		Description: General Specs and Notes					
	Rev Date & Description:				Material:		Rev: xx	Drawing Number: GE2024-AS		
	Date: 11/13/2015	Drawn By: DEB	1050 Columbia Drive, Carrollton GA 30117 Toll Free: 800-327-8774 Local: 770-832-6660			Weight:	Size: A	Units: Inch	Tol: ±.0625 Unless Otherwise Specified	Scale: NTS

GRATE ROTATES 180° FROM
OVER FIRE WITH 5 LBS. OF
FORCE. HANDLE IS NEVER
OVER FIRE

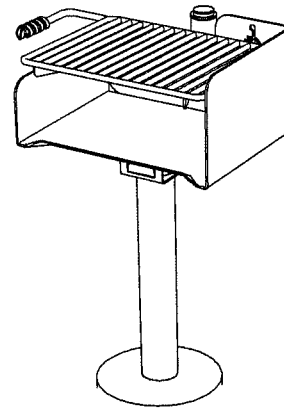
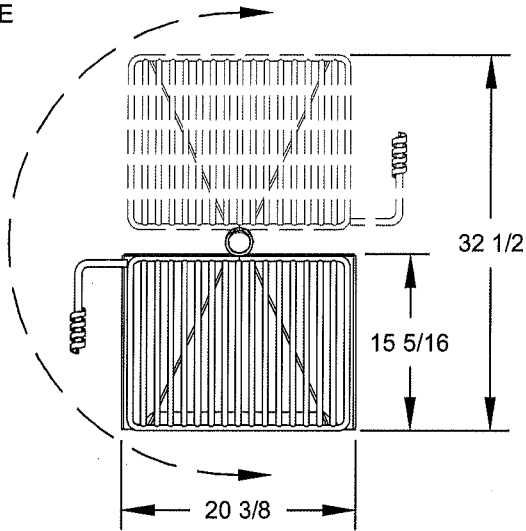

STANDARD B2 EMBEDDED POST
INSTALLATION

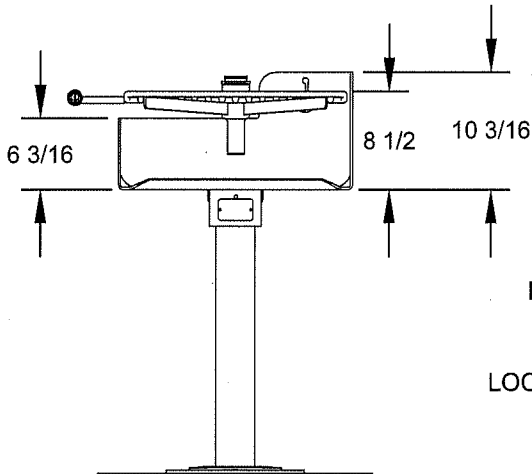

OPTIONAL B18 SURFACE MOUNT
INSTALLATION

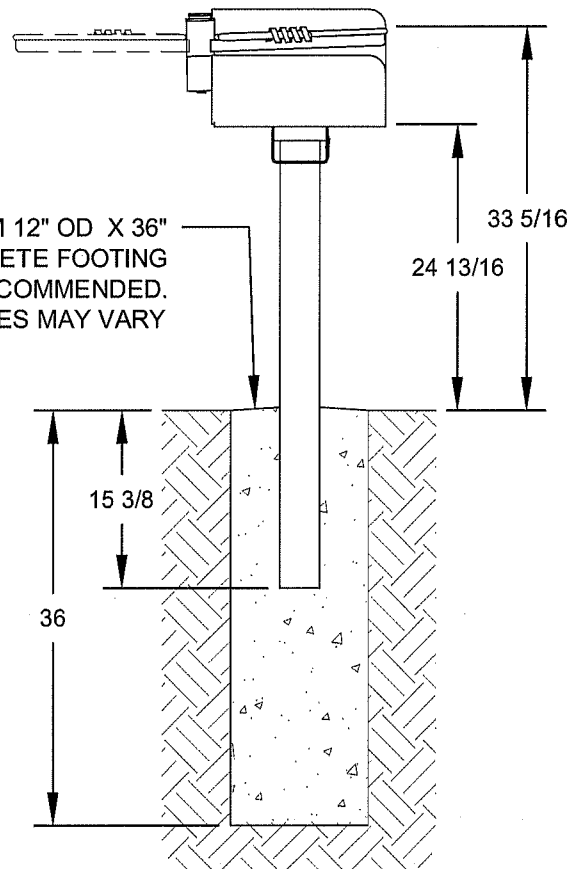

STANDARD B2 EMBEDDED POST
INSTALLATION

ALL DIMENSIONS IN INCHES

RJ Thomas
Mfg. Co., Inc.
P.O. Box 946
Cherokee, IA 51012

TITLE MODEL ASW-20 B2 ACCESSIBLE PARK GRILL WITH B2
EMBEDDED MOUNT BASE

DRAWN BY WWM

DATE 2-29-12

DWG. NO. AI-2013

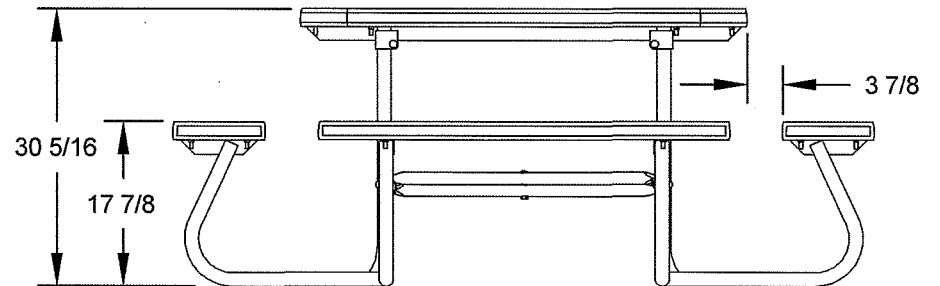
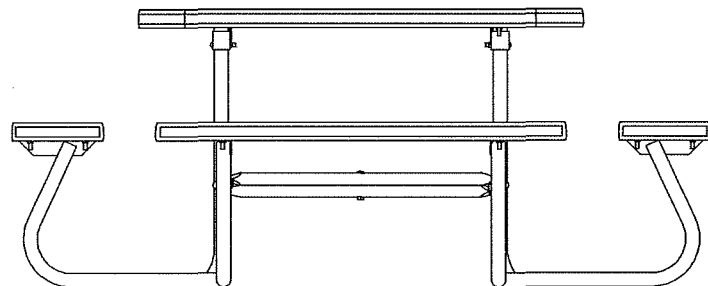
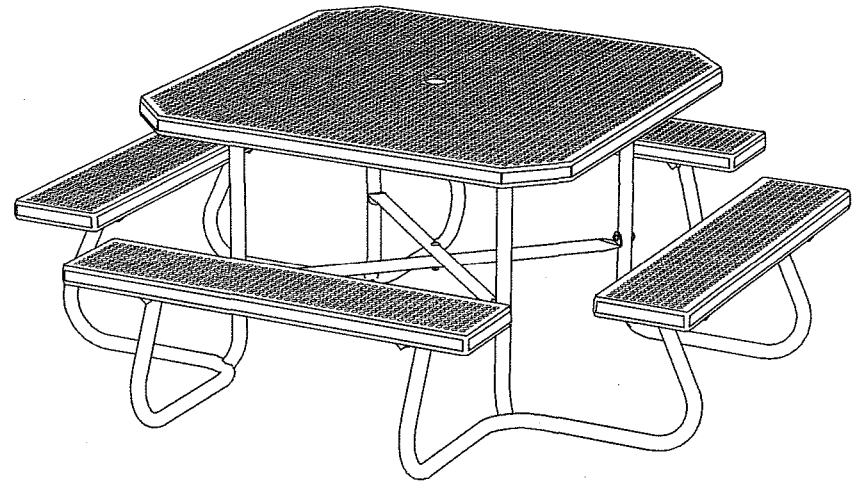
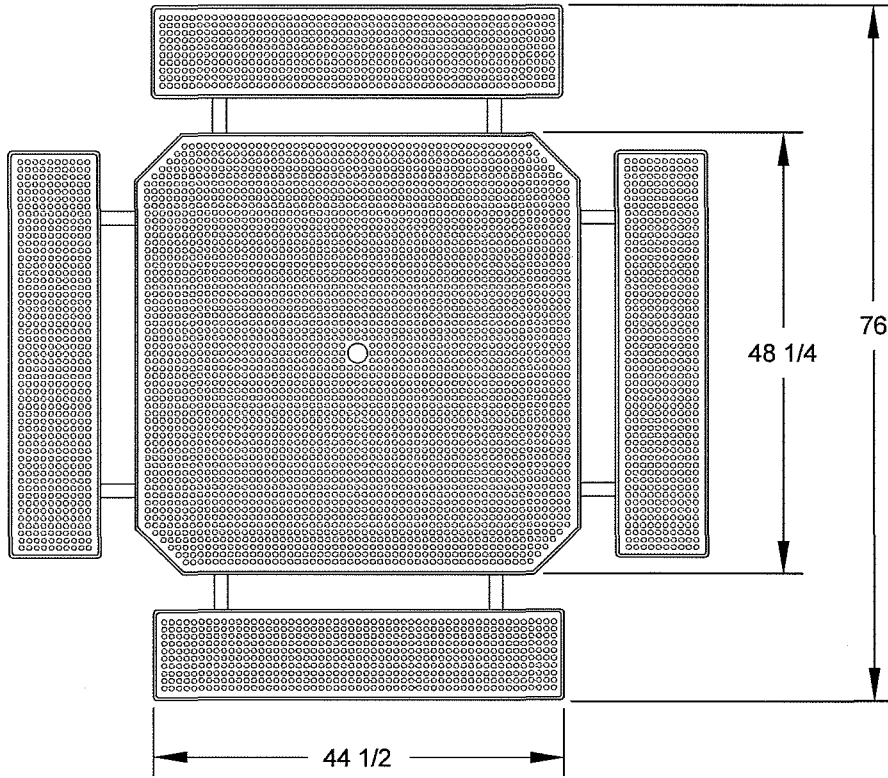

ALL DIMENSIONS IN INCHES

RJThomas Mfg. Co., Inc.
P.O. Box 946 • Cherokee, IA 51012-0946

DRAWN BY
WWM

TITLE **SQT SERIES 4 FOOT PORTABLE SQUARE TABLE WITH H-TYPE THERMO-PLASTIC COATED PERFORATED STEEL SEATS AND TOP**

DATE **3-03-10**

DWG. NO. **AI-1499**

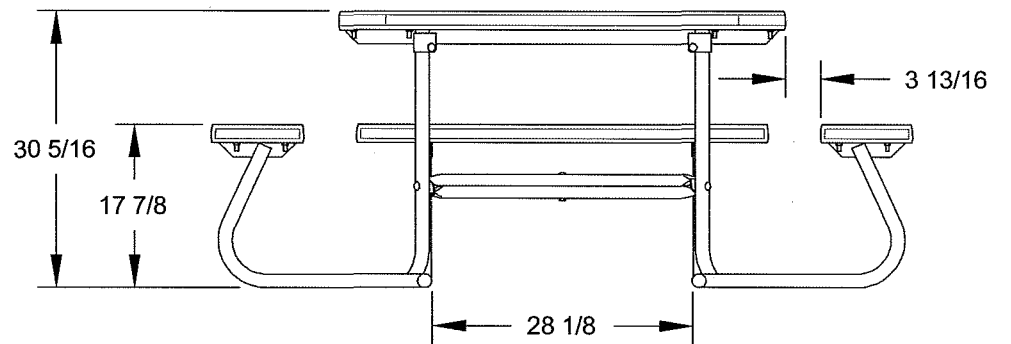
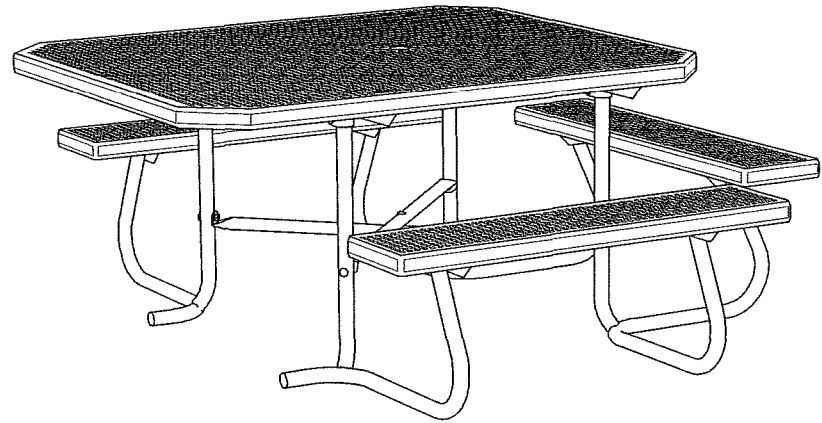
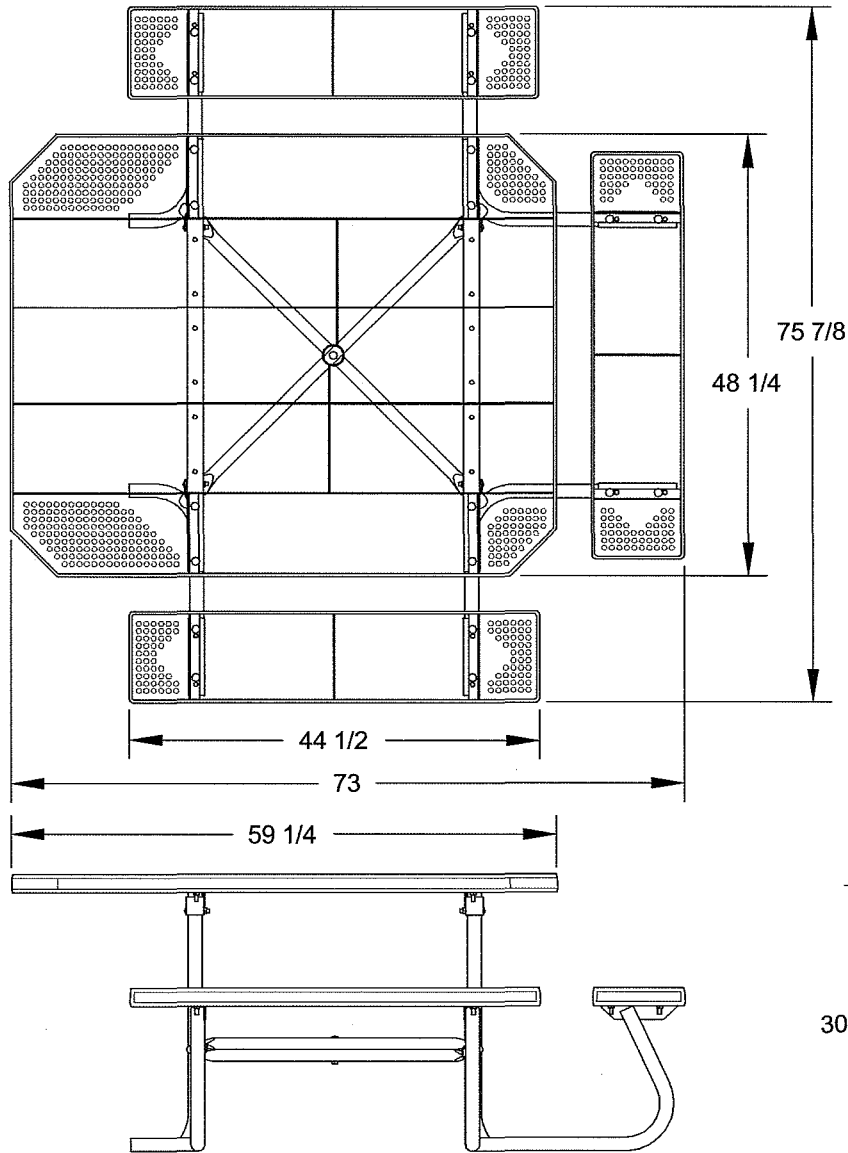

ALL DIMENSIONS IN INCHES

RJThomas Mfg. Co., Inc.
P.O. Box 946 • Cherokee, IA 51012-0946

DRAWN BY
WWM

TITLE **SQT3-4 SERIES 4 FOOT PORTABLE SQUARE TABLE WITH PLASTISOL COATED
H-TYPE PERFORATED STEEL SEATS AND TOP
TOP EXTENDED ONE FOOT ON OPEN SIDE**

DATE 11-07-08

DWG. NO. **AI-1834**