

# Residential Outdoor Lighting Zoning Regulations Overview



To reduce unwanted glare, the Zoning Ordinance contains standards for outdoor lighting.

## What's Required?

- Fixtures must be **full cut-off and mounted horizontal** to the ground. Full cut-off means that light is not emitted above the bottom of the fixture.
- Light bulbs must have a **color temperature** of 3,000K or less, except with an approved sports illumination plan. Check the package for this information.
- **Spotlighting** of flags, landscaping, or other similar objects must be aimed and shielded to confine the light to the object.
- On lots adjacent to residential, all lights must have a **setback** based on their height or have additional **shielding**.
- Light poles **7 ft. high** or less are allowed in any location; higher poles are subject to height and location standards.
- On all lots (including single family), sports fields/courts, including pools, over 10,000 square feet or with light poles that are 20 ft. high, are required to have an approved **sports illumination plan**.

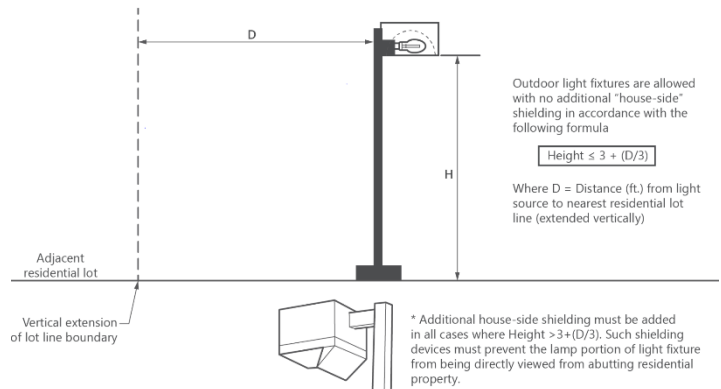
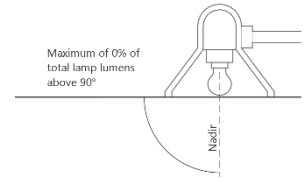

## What's Exempt?

- On lots with single family dwellings (including townhouses), lights do not need to be full cut-off or meet the setback/shielding requirement if:
  - The light fixture has **1,500 lumens** or less; or
  - The light is **motion-activated with 4,000 lumens** or less, turns off within 5 minutes of motion ceasing, and the light is directed within the property.
  - Check the package for this information.
- Holiday lighting.
- Depending on when the light was installed, it may be allowed to remain as is.

### Complaints:

To report a possible violation, please contact the Department of Code Compliance at 703.324.1300 (TTY 711) or send an email to: [DCCCodeComplianceE-mail@fairfaxcounty.gov](mailto:DCCCodeComplianceE-mail@fairfaxcounty.gov)

### Contact Us:

If you have any questions about these outdoor lighting regulations, please contact the Zoning Administration Division at 703.324.1314 (TTY 711) or send an email to: [ORDADMIN@fairfaxcounty.gov](mailto:ORDADMIN@fairfaxcounty.gov)

This publication summarizes a few regulations as of July 1, 2021. See the Fairfax County Zoning Ordinance for specific requirements.