

Fairfax County, Virginia

Typical Finished Basement Details

Based on the 2009 International Residential Code

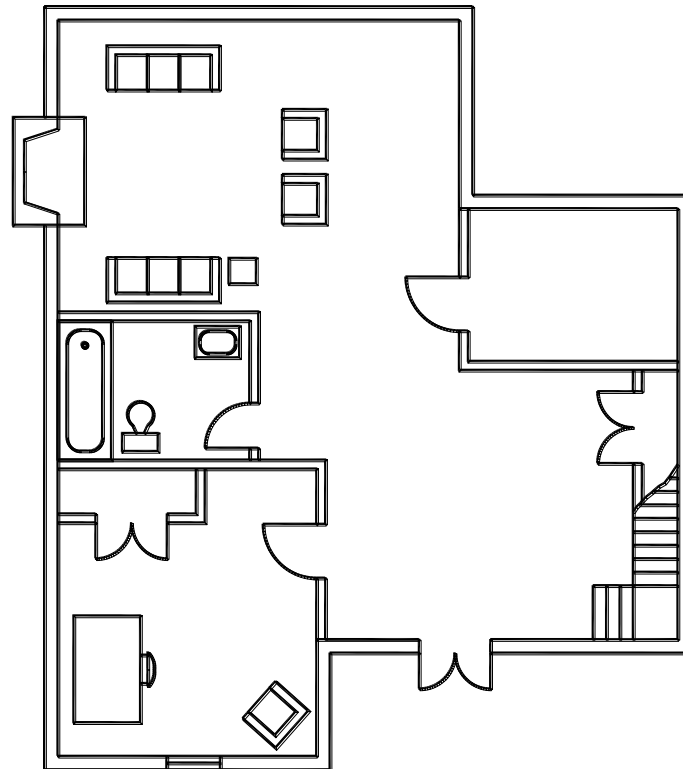

CONTENTS

General Requirements	2
Emergency Escape and Rescue	2
Wall Construction	3
Floor/ceiling Construction	7
Mechanical	7
Plumbing	8
Electrical	8

Finished basements must be constructed in conformance with these details. For requirements, details and information not contained herein, you must consult the Virginia Residential Code. Code books may be viewed [online](http://www.iccsafe.org) or purchased from the International Code Council at [iccsafe.org](http://www.iccsafe.org). A copy of these details is required to be available on the job site and available to the inspector during each required inspection.

GENERAL REQUIREMENTS

1. Habitable rooms (excluding closets, hallways, laundry rooms, storage spaces and bathrooms) shall have an area of not less than 70 square feet and shall not be less than 7 feet in any direction.
2. Hallways shall not be less than 36 inches in width.
3. The basement ceiling height shall not be less than 7 feet above the finished floor. Structural members may project a maximum of 6 inches below the required ceiling height provided they are spaced at 4 feet or more.
4. Bathrooms shall be equipped with a fan vented directly to the outside. A fan is not required if the bathroom is equipped with a window with an opening of 1.5 square feet or more.
5. Enclosed accessible space under stairs shall have walls and ceilings protected with $\frac{1}{2}$ -inch drywall on the enclosed side.
6. A smoke alarm shall be installed in the basement and in each basement bedroom. New smoke alarms shall be interconnected so that when one is activated all will sound. Smoke alarms must be hardwired with a battery backup.
7. A carbon monoxide alarm shall be installed in the basement if a bedroom is being constructed and the house is equipped with gas appliances. The carbon monoxide alarm must be hardwire, plug-in or battery type.
8. All basement stairs shall have a light source to illuminate all treads and landings. Lights shall be operated by a switch located at the top and bottom of the stairs.
9. A minimum of R-11 battened insulation (with the vapor barrier on the warm side of the wall) should be installed for the full height and length of the basement wall.

EMERGENCY ESCAPE AND RESCUE

Where Required

An emergency escape and rescue opening in the form of a window or door to the outside is required for all finished basements and in all bedrooms regardless of the house's age. However, openings in the bedroom may serve the entire basement.

If your basement does not currently have one of the emergency escape and rescue options below, then you must provide one. **Cutting openings in existing basement walls is outside the scope of these details. Therefore, a plan submission is required for the new openings only.** All other conditions of the finished basement may be taken from these details.

Emergency Escape and Rescue Options

- Window opening directly to the outside (walk-out basement condition).
- Window opening into a window well or areaway.
- Door directly to outside (walk-out basement condition).
- Door to bulkhead enclosure (Bilco or similar type door).

Requirements

- All doors and windows utilized for emergency escape and rescue must be operable from the inside without the need of a key or tool.
- The opening must be a minimum of 5.7 square feet. Windows in a walk out basement wall may have a clear opening of 5 square feet.
- Windows must have a sill 44 inches or less above the finished floor.
- See FIGURE 1 for more opening requirements.

New Basement Windows

All new windows installed shall have a U-factor of 0.35.

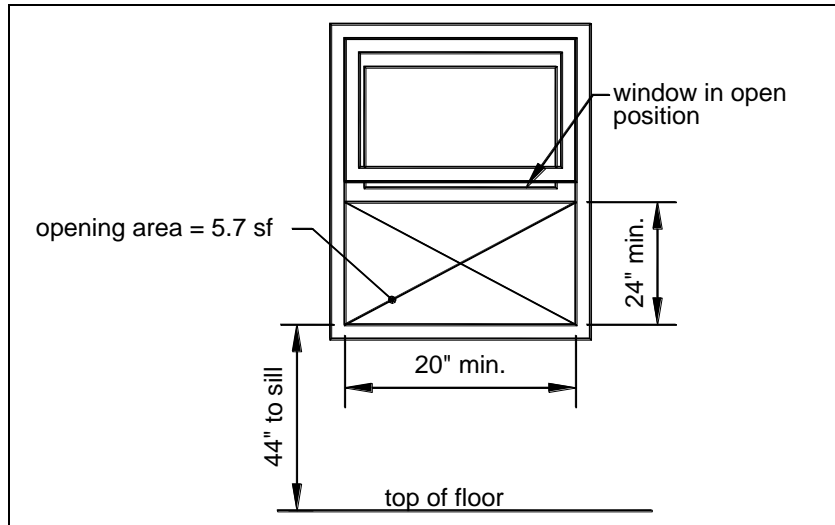

FIGURE 1: EMERGENCY ESCAPE AND RESCUE REQUIREMENTS

Window Well Requirements

When grade conditions require the sill of the windows to be below the outside grade elevation, then a window well must be constructed. The required horizontal area of a window well is a minimum of 9 square feet which is measured when the window is in the open position (this is important when the window is a crank-out type). See FIGURE 2.

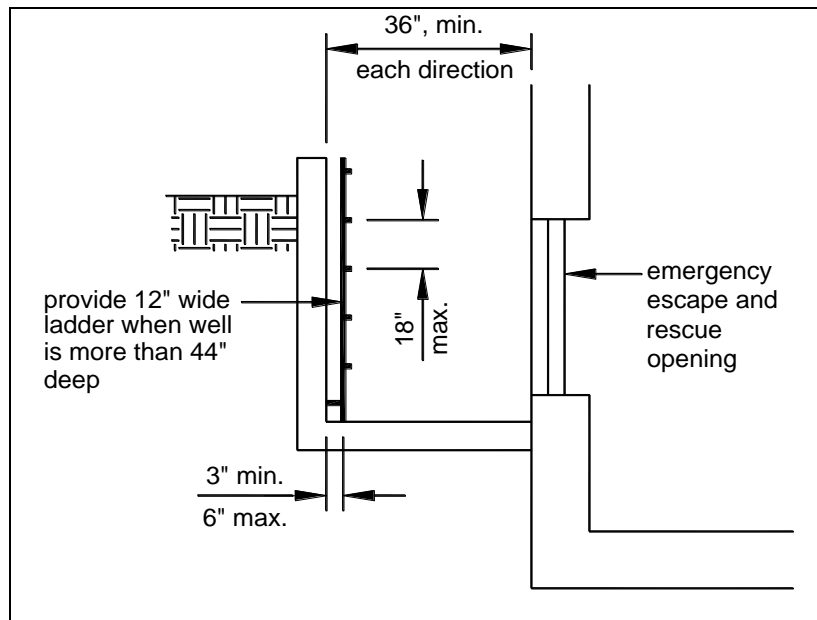

FIGURE 2: TYPICAL WINDOW WELL REQUIREMENTS

Window Well Construction

A plan submission is required for the construction of a new window well. You may use the Fairfax County [Typical Retaining Wall Details](#) for guidance. If you choose to use a prefabricated window well, you must submit the manufacture's specification during the permit application process.

Ladder Requirements

When a window well is deeper than 44 inches, a permanent, attached ladder or steps must be provided per FIGURE 2. If the ladder projects more than 6 inches into the required area, the size of the window well must be increased to maintain the required area.

WALL CONSTRUCTION

Studs

Studs may be utility grade or better. Stud shall be spaced per TABLE 1. Walls shall have a single pressure treated bottom plate and can have a single or double top plate.

TABLE 1: STUD SPACING

Wall Finish Material	Stud spacing, inches on center
Drywall	16 or 24
Wood veneer, hardwood paneling	16

Attachment Requirements

Wall construction shall be fastened in accordance with TABLE 2.

TABLE 2: FASTENING SCHEDULE

Connection	Nailing method
Top plate to stud	end nail, 2-16d @ 24"o.c.
Stud to bottom plate	toe nail, 2-16d
Bottom plate to floor	face nail, 6d (concrete nail) @ 16"o.c.

Drilling And Notching Studs

Studs in non-load bearing walls may be notched or drilled in accordance with FIGURE 3.

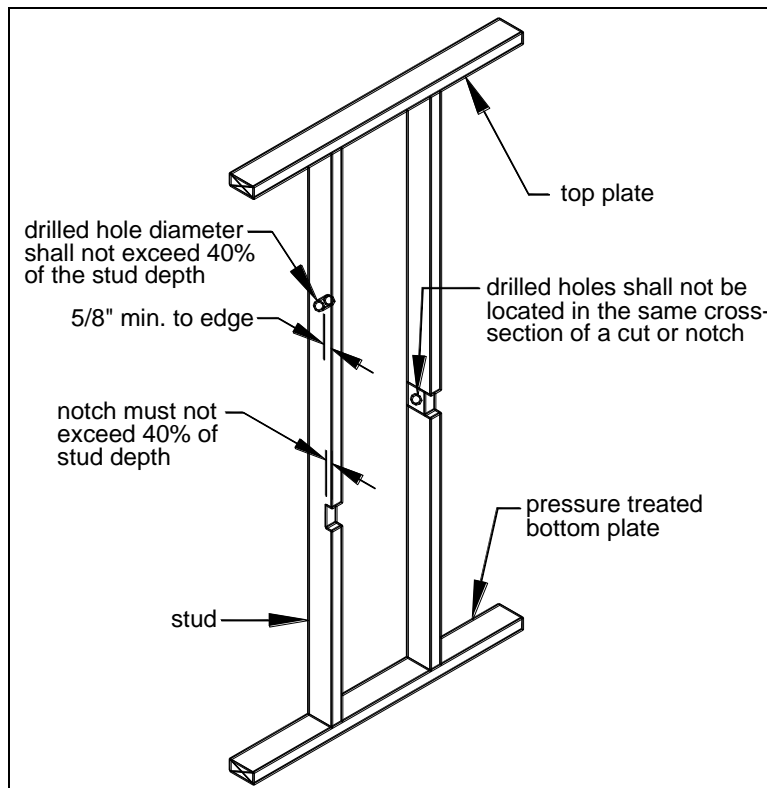

FIGURE 3: DRILLING & NOTCHING STUDS

Headers

A single flat 2x4 member may be used as a header in interior nonbearing walls for openings up to 8 feet in width if the portion of the wall above the opening is not more than 24 inches in height. If the opening does not meet these conditions, the header size shall be per TABLE 3.

TABLE 3: HEADER SIZE

Header Size	Span length, feet
(2)2x4	4
(2)2x6	6
(2)2x8	10
(2)2x10	12
(2)2x12	16

Fire Blocking

Fire blocking shall be provided to seal off concealed spaces and to form an effective fire barrier between stories. See FIGURE 4 - FIGURE 7. Fire blocking shall be provided in the following locations.

- In concealed spaces of stud walls and partitions, including furred spaces, at the ceiling and floor level and at 10-foot intervals horizontally;
- At all interconnections between concealed vertical and horizontal spaces such as occur at soffits, bulkheads, drop ceilings, cove ceilings, etc.;
- In concealed spaces between stair stringers at the top and bottom of the run.
- At gaps 1 inch or less and at openings around vents, pipes and ducts at the ceiling and floor level; batts or blankets of mineral wool or fiberglass must be used.

Fire Blocking Material

Fire blocking shall consist of one of the materials listed below.

- 1/2-inch gypsum board.
- 2x lumber (2x4, 2x6, etc.).
- Two thicknesses of 1x lumber (1x4, 1x6, etc.) with staggered joints.
- One thickness of 23/32-inch of plywood or OSB with joints backed a minimum of 6 inches with the same material.
- One thickness of 3/4-inch particleboard with joints backed a minimum of 6 inches with the same material.
- 1/4-inch cement based millboard.
- Batts or blankets of mineral wool or fiberglass.

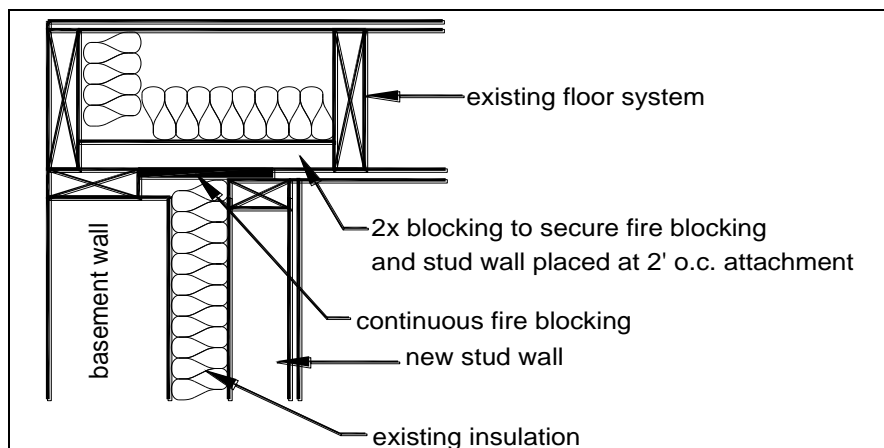

FIGURE 4: FIRE BLOCKING WITH OFFSET STUD WALL

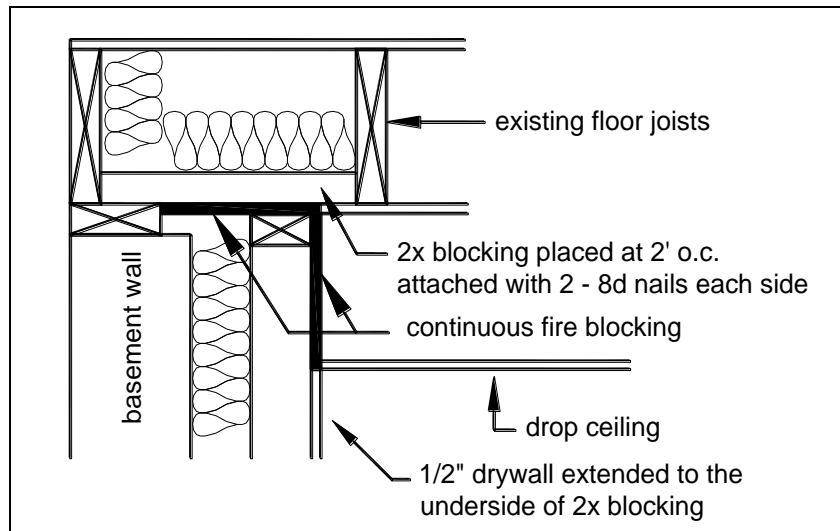

FIGURE 5: FIRE BLOCKING AT DROP CEILING

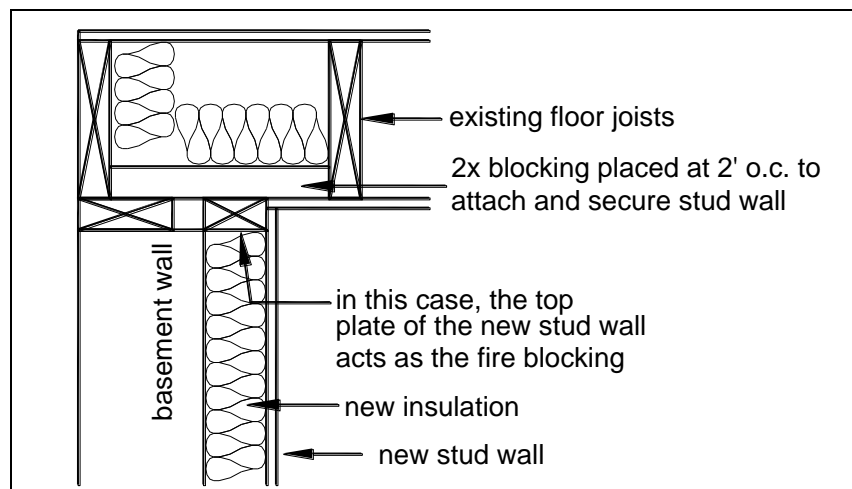

FIGURE 6: FIRE BLOCKING WITH STUD WALL AGAINST BASEMENT WALL

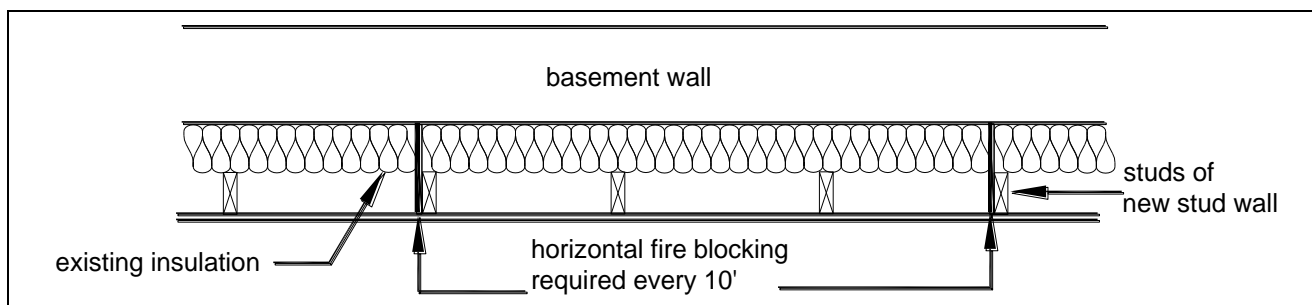

FIGURE 7: HORIZONTAL FIRE BLOCKING (LOOKING DOWN)

Interior Covering

Wall and ceiling material must meet the requirements below.

- Materials must have a flame spread classification no greater than 200 and a smoke density classification no greater than 450. This does not apply to trim, molding, handrails and doors.
- Cement or fiber-cement board (e.g., Durock) must be installed on walls of bathtub and shower spaces and finished with a non-absorbent surface.
- Wood veneer or hardboard paneling less than 1/4-inch shall not be permitted.
- Gypsum board must be 1/2-inch minimum.

FLOOR/CEILING CONSTRUCTION

Drilling And Notching Joists

Drilling and notching dimensioned lumber shall be in conformance with FIGURE 8. Cantilevered (overhanging) joists cannot be notched. Drilling and notching of manufactured wood I-joists shall be per the manufacturers' instructions.

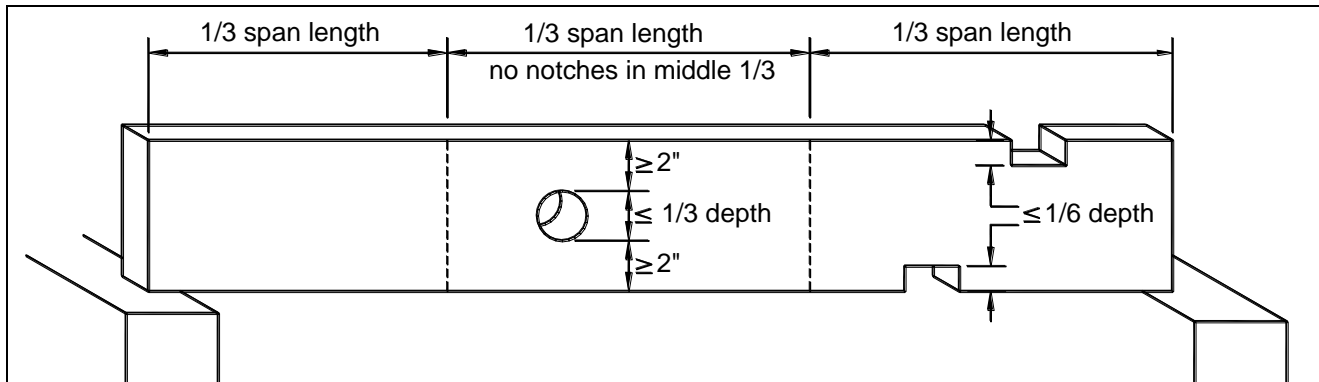

FIGURE 8: DRILLING AND NOTCHING OF JOISTS

Draftstopping

When a ceiling is not directly attached to the underside of the floor joists above or when the floor joists are comprised of open web trusses, draftstopping must be provided. Install draftstopping to create equal-sized concealed areas not exceeding 1,000 square feet. Draftstopping shall be installed parallel to the floor framing members. See FIGURE 9 and FIGURE 10.

Draftstopping Material

Draftstopping shall consist of $1/2$ -inch gypsum board, $3/8$ -inch wood plywood/OSB or $3/8$ -inch particleboard, Type 2-M-W.

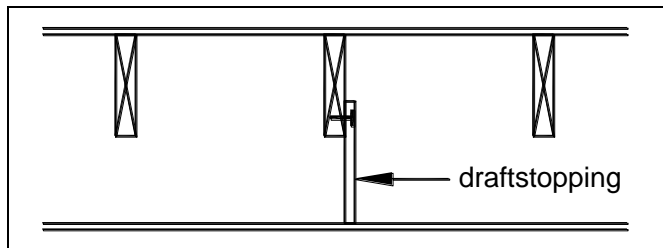

FIGURE 9: DRAFTSTOPPING AT DROP CEILING

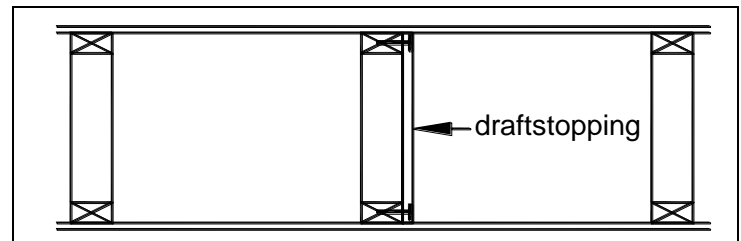

FIGURE 10: DRAFTSTOPPING AT OPEN WEB TRUSSES

MECHANICAL

Appliance Access

Furnaces, water heaters and other appliances must be accessible without removing permanent construction and shall meet the following minimum criteria.

- 30 inches x 30 inches clear floor space at front/control side.
- Doors to furnace rooms shall be 24 inches minimum and be of sufficient size to remove the largest appliance.

Combustion Air

Furnace rooms with fuel-burning appliances must be provided with two permanent openings to adjacent spaces: one within 12 inches of the top and one within 12 inches from the bottom of the adjoining wall. Each opening must have a minimum free area equal to 1 square inch per 1,000 Btu per hour input rating of all appliances in the furnace room, but not less than 100 square inches. The openings are not required

if a louvered door is provided or the furnace room area is greater than 50 cubic feet per 1,000 Btu per hour input rating of all appliances installed in the room.

PLUMBING

Showers

Showers and shower compartments must meet the following requirements.

- Shower compartments must have a minimum total area of 900 square inches and a minimum dimension of 30 inches in any direction.
- Shower compartments may have a minimum dimension of 25 inches provided it maintains a cross section area of 1,300 square inches.
- Hinged shower doors must open outward.
- All glass which encloses a shower must be safety glazed.
- Shower control valves must be scald resistant (in accordance with ASSE/ANSI 1016) with a hot water limit of 120 degree F.

Fixture Clearances

Toilets, sinks and showers shall have the minimum clearances listed below.

- 21 inches in front of sinks and toilets.
- 24 inches in front of shower stall opening.
- 4 inches between two adjacent sinks.
- 4 inches between a sink and a toilet.
- 4 inches between a sink and a wall.
- 2 inches between a sink and a bathtub.
- 15 inches clearance from a toilet's centerline to an adjacent fixture or wall on each side.

Drain Size

Fixture drain size must meet the dimensions below and must be equipped with a strainer and stopper.

TABLE 4: MINIMUM DRAIN SIZE

Fixture	Diameter, inches
Bathroom sink	$1\frac{1}{4}$
Bathtubs	$1\frac{1}{2}$
Sinks (other than bathroom)	$1\frac{1}{2}$
Laundry tubs	$1\frac{1}{2}$
Shower	$1\frac{1}{2}$

Clothes Washer Discharge

The discharge of a clothes washer must be through and air break as shown in FIGURE 11.

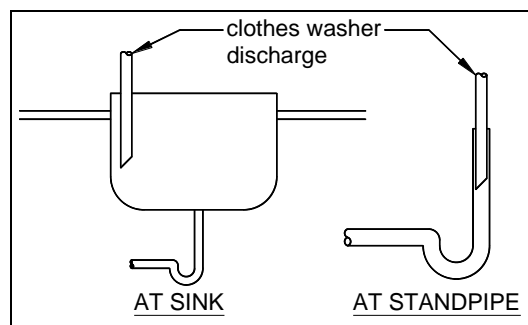

FIGURE 11: AIRBREAK AT CLOTHES WASHER DISCHARGE

ELECTRICAL

Panelboard (Circuit Breaker Box)

Panel boards must meet the requirements listed below.

- A workspace 30 inches wide and 36 inches deep from floor to the ceiling with a minimum height of 6.5 feet shall be provided in front of the panel boards.
- Panel board workspace must not be used for storage at any time.
- Panel boards must not be located in clothes closets or bathrooms.
- Provide a light for the panel board workspace.
- Pipes or ducts cannot be located above the panelboard.

Branch Circuits

Branch circuits must meet the requirements listed below. See TABLE 5 for more information.

- Use a 15- to 20-ampere rated branch circuit for general use purposes such as lighting and outlets.
- One "plugged-in" electrical device shall not exceed 80 percent of the circuit rating.
- Hardwired appliances or equipment may be included in a general use circuit provided its rating does not exceed 50 percent of the circuit rating.
- A dedicated 20-ampere minimum branch circuit must be provided to serve laundry room outlets only.
- A dedicated 20-ampere branch circuit must be provided to serve the bathroom receptacles.
- Branch circuits which serve bedroom outlets must have circuit breakers equipped as combination arc-fault/over current circuit interrupters.

TABLE 5: BRANCH CIRCUIT REQUIREMENTS

Circuit Rating→	15 amp	20 amp	30 amp
Circuit Element↓			
Minimum conductor size	14	12	10
Maximum breaker size	15	20	30
Outlets rating	15	15 or 20	30
Maximum load	15	20	30

Lighting Requirements

Lights must meet the requirements listed below.

- At least one switched light shall be provided in each room and hallway. A switched outlet may be substituted in all rooms except bathrooms and hallways. A switched outlet cannot count as a required outlet.
- At least one switched or pull chain light must be provided in each storage area and at or near heating and air conditioning appliances and equipment.
- Lighting fixtures must not be installed within 3 feet horizontally and 8 feet vertically of a bathtub rim or shower stall threshold. A light fixture may be installed above a shower area if it is constructed so that water cannot enter or accumulate in wiring areas and the lighting fixture is marked "suitable for wet locations."

Outlets

Outlets must meet the requirements listed below.

- Outlets shall be placed in accordance with FIGURE 12.
- The minimum wall length which requires an outlet is 2 feet.
- Kneewalls, built-in bars and other fixed room dividers must be included for outlet spacing.

- Hallways more than 10 feet long must have a minimum of one outlet.
- Outlets installed for specific appliances must be within 6 feet of the appliance location.
- Bathrooms must have at least one outlet located on a wall adjacent to each basin and within 36 inches of the bathroom sink. All bathroom outlets must have ground fault circuit interrupter (GFCI) protection.
- At least one outlet must be provided to serve laundry appliances and sinks.
- Each unfinished portion of the basement is required to have at least one outlet that is GFCI protected.
- An outlet must be provided within 25 feet of heating and air conditioning appliances and equipment.

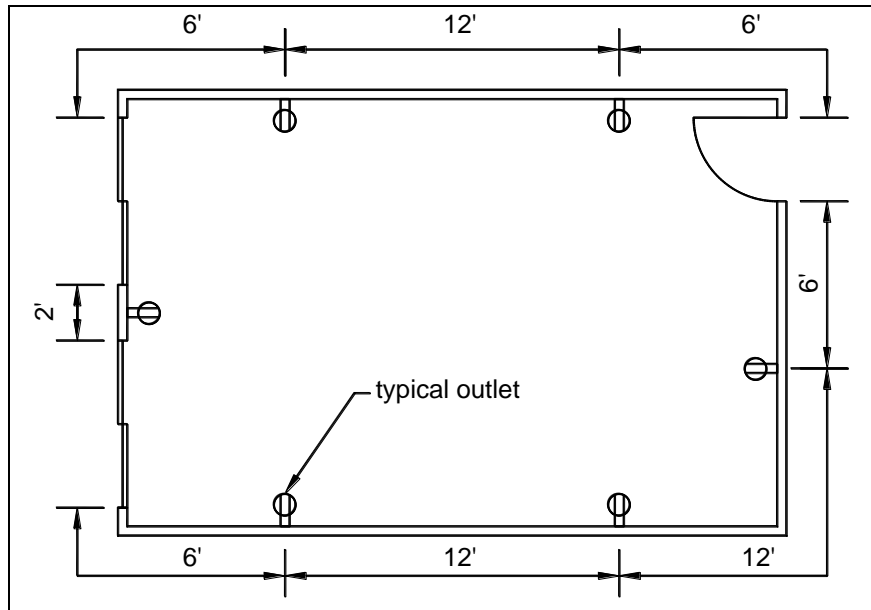

FIGURE 12: TYPICAL OUTLET DISTRIBUTION

Light Fixtures In Closets

Fixtures installed in clothes closets shall be limited to surface mounted or recessed incandescent fixtures with completely enclosed lamps and surface mounted or recessed fluorescent fixtures. See TABLE 6 for clearance requirements.

TABLE 6: CLOSET LIGHT FIXTURE CLEARANCES¹

Fixture Type	Fluorescent Bulb ²	LED Bulb ²
Surface mounted	6"	12"
Recessed	6"	6"

¹ Incandescent bulbs are prohibited.

² Fluorescent and LED bulbs are permitted in storage areas when identified for this use.

Fairfax County is committed to a policy of nondiscrimination in all county programs, services and activities and will provide this document in alternative formats and in different languages upon request. Please call **703-324-5033, TTY 711** or write Department of Public Works and Environmental Services, Suite 659, 12055 Government Center Parkway, Fairfax, VA 22035-5506. Please allow at least seven working days for preparation of material.