

16000 – ELECTRICAL

I. DESIGN

A. Electrical Main Services

1. Where appropriate a three-phase four wire 277/480 volt main service is preferred. A circuit breaker coordination study shall be provided when the complete single line diagram is established and with the final sizing of the main service. Two (2) sets of spare fuses for each phase shall be provided for the Main Service served by a Fusible Main Service Disconnect. Site Plans shall indicate the routing of the incoming electric utility lines from the supply source to the electric room in the building. A spare underground conduit shall be provided from the utility pole to the pad mounted transformer for high voltage lines, as required by the utility. A spare conduit shall also be provided from the utility pad mounted or pole mounted transformer to the CT cabinet for future use. All building wiring shall comply with the requirements of the Fairfax County adopted issues of the National Electrical Code (NEC).
2. Main Switchboard/Switchgear or the Main Distribution Panel (MDP) shall be provided with at least 25% spare capacity and space for future use. Provide a spare breaker corresponding to each nominal panel board size such as 100A, 225A, and 400A for building greater than 50,000 square feet. In all buildings less than 50,000 square feet in size, provide two spare breakers in the switchboard for future use as a replacement or addition for renovations. For 480 Volt systems, provide a spare 100 amp-42 circuit-120/208 Volt panel board with a built-in step down transformer.
3. The emergency power distribution system (Life Safety), without a generator or UPS system, shall be tapped ahead of the main and should have a disconnecting means with overcurrent protection and lock out capabilities for service and repairs. Emergency power systems shall comply with the 2011 NEC and NFPA 110 requirements.
4. To comply with OSHA's lock out and tag out requirements disconnects, panel boards and all other electrically powered equipment shall have a means of de-energizing and locking out the equipment for service and repairs.
5. Trapeze mounted transformers 75 kVA and above, shall have supporting structure that has been designed by a structural engineer.
6. Equipment rooms where switchboards, panel boards or transformers are installed shall be properly ventilated and conditioned to prevent ambient temperature from exceeding the listed environmental limits of the equipment residing in the space.
7. Data and communication rooms shall be designated as separate rooms from the electrical rooms. This is necessary to keep cable clutter, risk of electrical shock, heat,

and EMF interference to a minimum. All data and communications rooms shall be provided with receptacles that are powered by standby generator circuit. No electrical transformers or distribution panels shall be permitted in telephone/data or communications rooms or closets.

8. The working space around electrical panels and other electrical devices must meet NEC requirements for clearance, and provide necessary space for access, although, the standard NEC required clearances may not be sufficient in all cases. The working space in front of electrical panels and other electrical equipment shall be sufficient to provide safe working space to minimize exposure to flash hazard.
9. Access to the electrical panels and other electrical equipment shall be limited to qualified electrical staff by providing locks and appropriate signage to restrict direct entry and prevent flash hazards. A flash hazard analysis shall be done on all panels, switchboards, motor control centers and control panels and an arc flash hazard warning label be posted on these equipment in accordance with NFPA 110.16 and NFPA 70E as required by the adopted NEC. A circuit breaker coordination study and an arc flash analysis are required for all new and modified services.
10. Specifications shall require installation of electric demand meters/monitors as part of the Building Automation System.
11. Main Electrical Room lighting in non-generator or UPS powered emergency systems, and one 20 ampere duplex receptacle for all indoor main services shall be provided, and fed from the Life Safety Panel (ELS) which is connected from a tap ahead of the main circuit breaker of the service.

B. Riser Diagrams and Panel Schedules on Electrical Drawings

1. Specifications shall require the installing Electrical Contractor to provide 1/4"=1' scale layouts of all electrical and data/communications rooms showing Switchboard/Switchgear, MDP, panel boards and transformers prior to installation. This shall also be required as a submittal in the Submittal part of the applicable specification sections.
2. Indicate on each panel schedule as "Fed from -----". This designation shall be required to be shown on typed panel schedules posted inside the panels and labeled on the panel's front cover with an engraved phenolic plate, red background with white lettering, in the field by the installing Electrical Contractor.
3. Provide computed NEC demand load on all panels and sub-panels utilizing NEC demand factors as per panel schedule attached as 16000 - Exhibit #1. In addition show the load corresponding to the "feeder ampacity" and the "connected load" to determine the adequacy of the panel per NEC. A "Total Facility Load Analysis Table" based on the connected loads shall also be provided on the riser diagram at 100% Construction Documents submission.

C. Generator and Transfer Switches as Required

1. The A/E shall coordinate the requirements for the connection of building systems to the generator per project. New buildings shall have emergency equipment and distribution above grade and comply with Article 708 of the NEC for Critical Operations Power Systems requirements for equipment and materials used in the project. Existing facilities with new or reused equipment shall be installed above grade, in locations as allowed in Article 708 of the NEC. Branch feeders and circuits in existing facilities shall be installed in a method allowed by NEC 708.10, exclusive of the 2 inches of concrete requirement. In police stations all facility systems shall be on the generator with the exception of the air cooling system. Refer to Fire Station Design Manual for requirements on the fire stations. Coordinate with the County Project Manager for all other facilities.
2. The emergency generator system for new construction projects shall be designed such that load shedding is not required in order to pick-up the required connected emergency loads. Generator Systems to be refurbished or upgraded from the existing systems, where physical size constraints limit the generator size and/or the fuel tank capacity, load shedding shall be permitted (subject to FMD direction) to ensure critical operations portion of the building shall be energized by emergency power during an outage. Connected loads on the emergency system shall be limited to the minimum code requirements and other operational requirements. Provide generator sizing calculations and projected run time utilizing any of the manufacturer's available generator sizing programs.
3. Where load shedding is permitted, the operation of emergency egress and exit lighting, alarms and alerting systems, operations lighting, communications systems, sump pumps, automatic door operators shall be Priority Level I. Loads of refrigeration equipment, elevators, supplemental security systems and supplemental communication systems and disaster shelters shall be Priority II. Cooking equipment and non-essential operations shall be Priority Level III.
4. Where it is not required or not feasible to size the replacement generators and associated fuel supplies to power the entire facility, the generator shall power the emergency life safety system and designated standby power for elements of the facility in accordance with the Priority Levels established in the above paragraph. FMD shall designate which elements will receive direct emergency standby power and which elements shall be subject to load shedding.
5. Where an Uninterruptible Power Supply (UPS) or any non-linear loads are connected to the generator, proper allowances shall be made for such loads in the generator sizing computer program. Leading power factor equipment shall not comprise more than 40% of the generator capacity. Provide approximately ten percent (10%) spare capacity in the generator to carry future loads.

6. Evaluate emergency generator system to determine whether or not an air permit will be required based upon Virginia Department of Environmental Quality standards.
7. The specifications for the generator shall include the following items:
 - a. The Jacket Water Heater shall be provided with a set of water shutoff valves for all units to facilitate jacket water hose and heater replacement without the necessity of draining the engine coolant system.
 - b. The main circuit breaker shall be provided with auxiliary contacts to indicate light and alarm on the generator control panel and the Remote Generator Annunciator Panel (RGAP) when the main circuit breaker is in “OFF” position. Also provide a Red Mushroom “Emergency Stop Button” on the engine control panel. Depression of this emergency stop button shall trip the main circuit breaker and initiate generator shutdown.
 - c. Provide an “Emergency Stop Button” at the egress point of the generator room or enclosed space.
 - d. Specify that EPA Emission Levels shall be in accordance with EPA New Source Performance Standards (NSPS) regulations. Indicate manufacturer’s published emissions for the style, model and capacity of the generator provided on the drawings.
 - e. The mode switch located on the generator control panel shall be labeled “Run-Off-Auto” per NFPA 110. Provide contacts to indicate light and alarm when the mode switch is “not in Auto position” on the generator control panel and the RGAP. Provide for remote monitoring of the generator status to the fire alarm panel and be compatible with incorporation into and reporting to the County EDGAR software program.
 - f. The batteries shall be 4-D. Maintenance Free batteries are not acceptable.
 - g. The generator shall be required to meet Fairfax County Noise Ordinance Requirements at the property line. A/E shall stipulate what the maximum allowed db level is within the specifications.
 - h. Manufacturer’s recommended electronic interface device shall be provided to the Owner, by the contractor, for diagnostics on all new generators.
 - i. A 100 amp, single phase Generator Accessory Panel (GAP) with 8 (eight) circuit capacity, including the main circuit breaker integral to the generator shall be specified and mounted nearest to the engine control panel inside the protective housing for units 100 kW and greater and all units with Day Tanks. The GAP shall be factory hard wired to provide power circuits for the jacket water heater, battery charger and the 20-amp duplex receptacle which shall be also located on

the side of the engine control panel inside the generator housing. Provide two spare 15 ampere circuit breakers – (one for wiring the day tank controls and other for future use). Provide the remaining two slots in the generator panel as spaces for future use. Provide a 1-1/2” conduit from the designated Life Safety panel to provide power conductors for the GAP.

- j. Locate the generator exhaust as far away as possible from the building air intakes and/or any operable windows. The minimum separation distance shall be 25 feet. If not feasible to provide the minimum 25 feet, written approval is required from FMD and the Project Manager. The generator muffler shall be located inside the outdoor generator set enclosure.
- k. Specifications for 250 kW and larger shall require data from a factory reactive load bank test and a resistive load bank test. The Contractor shall conduct an on-site field load bank performance test with unity power factor in accordance with NFPA – 110 requirements for all new emergency generators. Final mechanical (Generator, Main Fuel Tank and Day Tank) inspections shall have been completed prior to initial start-up of the generator. Two days’ notice shall be given to the Project Engineer to coordinate the initial start-up tests. Approval of preliminary electrical inspection shall be a pre-requisite for the start of performance and acceptance (Load Bank) tests. Load Bank Test shall be witnessed by the Project Manager (Construction Project Engineer or FMD Project Engineer). Two days’ notice shall be given to the Project Manager (Construction Project Engineer and FMD Project Engineer) to coordinate the performance and acceptance tests. The performance test results shall be signed off by the Owner (Construction Project Engineer or FMD Project Engineer). The building loads shall be transferred to the generator system after the load bank tests have been accepted.
- l. All new or replacement generators shall have a non-fusible 3 position double throw disconnect and a connection box for a roll up generator, installed for units up to 1200 amperes. Generators rated greater than 1200 amperes shall be provided with a tap - box to facilitate the connection to a manual transfer switch.
- n. Provide a 24 (twenty four) light LED Remote Generator Annunciator Panel (RGAP) next to the Fire Alarm Control Panel (FACP) or an other location as determined by specific needs of the facility. A separate 1” conduit with 2 twin axial shielded cables (Beldon 9413) and twelve (12) #12 stranded copper conductors shall be provided from the generator control panel to the RGAP. The RGAP shall comply with the requirements of NFPA 110 with the following extra lights as optional on all projects (Additional lights may be added as necessitated):
 - Day Tank Trouble Alarm
 - Normal Power
 - Generator Running
 - Generator Fault (Trouble)

- Main Circuit Breaker “OFF” position
 - Green Light indicating “Panel Disarmed Temporarily”
 - Spare
 - Spare
- o. Provide a separate 1” conduit with 16- Cat 5 control wires from the Automatic Transfer Switch (ATS) to the Generator Engine Control Panel (GECP) for the purpose of providing start-stop controls and ATS position indication, other required controls, and future controls.
 - p. Provide a separate 1” conduit from the generator control panel for connecting the Day Tank control wires.
 - q. Provide a separate 1” conduit from the 60 amp GAP to the Day Tank for the power conductors.
 - r. Provide an RS Generator Alarm Panel.
 - s. The generator must be designed to run on ultra-low sulfur diesel fuel.
 - t. See Mechanical Division 15000 - 1.E.1 if fuel tank and fuel delivery system supply other onsite equipment in addition to the emergency generator.
 - u. The fuel tank shall be sized to provide emergency generator fuel for 96 hours. Coordinate with the FMD Project Manager to determine the required loads on the generator in each project. See Mechanical Division 15000 - 1.E.7. If space does not permit capacity for 96 hours, then provide a tank with capacity for 72 hours minimum.
 - v. Provide a Generator Connection Box per attached 16000 – Exhibit #2 with separate 1” conduits from each ATS and the Generator containing eight (8) #12 stranded copper control wires. Provide conduit and wiring for the two receptacles in the Generator Connection Box to be fed from the Life Safety and Standby panels respectively. Life Safety Panels shall be designated as EHLS & ELLS for 480 Volt Systems and ELS for 120 Volt Systems with corresponding Automatic Transfer Switches as EHLS and ELS respectively. For the Stand-by Panels the designation shall be EHSB & ELSB for 480 Volt Systems and ESB for 120 Volt Systems. Corresponding Automatic Transfer Switches for the standby panels shall be designated as EHSB and ELSB for 480 Volt and 120 Volt respectively.
 - w. The generator and automatic transfer switch shall be covered by the full one-year warranty for the project, in addition to more extensive warranties offered by the specified manufacturers for equipment and labor. The contractor shall respond within two hours for any generator failures or problems that occur during normal or after hour timeframes during the one-year contractor warranty period, including weekends and holidays.

- x. The Automatic Transfer Switch shall be complete with the isolation and bypass features to facilitate the equipment servicing without shutting off normal or emergency power to the facility.
- y. Final inspection of the Emergency generator and the fuel tanks (main and Day Tanks) and fuel piping associated with the emergency generator system shall be performed by the Fire Marshall's office and the County's mechanical and electrical inspectors after the start-up of the generator has been completed, all wiring has been installed, and prior to the performance of the load bank test. After the load bank test has been accepted, the building loads are to be transferred to the generator system. A generator schematic detail shall be provided indicating all conduit stub-ups emanating from the generator pad to the Three Position Switch, Generator Connection Box, any Equipment Rack, Day Tank and Electric Room similar to illustration shown as 16000 – Exhibit #3.
- z. O&M training for Emergency Standby Generators and Automatic Transfer Switches shall be conducted by a certified training instructor provided by the manufacturer and shall be performed on-site after the startup and acceptance tests of the generator have been completed.
- aa. Specialized maintenance servicing tools (diagnostic tool, laptop computers etc.) required for Emergency Standby Generators and Automatic Transfer Switches shall be provided by the installer and shall be transmitted to FMD.

D. Grounding and Bonding

1. Provide grounding as per NEC. Additional grounding rods may be required to achieve 5 ohms or less. A test well shall be provided for one of the main grounding grid rods and the location of the test shall be marked on the Site Plan.
2. A main grounding bar shall be installed inside the electrical room, and connected to the grounding rods, lightning protections system (where necessary), building steel, counterpoise and main water pipe. All secondary transformer neutrals shall be connected to this grounding bar.
3. Main service neutral shall be bonded at the service entrance disconnect and the grounding bar in accordance with NEC requirements.
4. A counterpoise or grounding grid around the entire generator is required as per 16000 – Exhibit #4. The generator and the Main Fuel Storage Tank and the Day Tank shall be grounded and this grounding grid shall be bonded with any other building grounding grid or the Lightning Protection System grounding.

5. Generator pad shall be minimum 12" above grade monolithic pad. Outside dimensions of the pad shall exceed that of the generator set a minimum of 12" on all sides with 3/4" chamfer.

E. Receptacles

1. GFCI and ARCH FAULT receptacle circuits shall not share neutral wires with normal circuits. Sharing of neutral wires should also be avoided on receptacles that may be used for any type of computer or equipment with a switch-mode power supply. Each circuit shall be provided with its own neutral wire.
2. Use of outdoor receptacles shall be minimized. Where provided, outdoor receptacles shall be designed to limit access to authorized personnel, only. Provide receptacles adjacent to exterior mechanical equipment for maintenance purposes per NEC requirements.

F. Fire Alarm System

1. The installer of the fire alarm and Fire Suppression Systems (see Section 15000) shall be required to provide four complete sets of Maintenance and Operation manuals, parts manuals, and list of local vendors for the system to the Owner at Substantial Completion.
2. The Contractor shall turn over fire alarm system keys, operations and maintenance manuals, and as-built drawings to Owner at or before Substantial Completion.
3. The Contractor shall provide as-built drawings prints, as-built schematic diagrams and wiring diagrams, keys to cabinets, panels, and manual stations and any access codes shall be provided to the Owner at Substantial Completion.
4. The contractor shall provide a system for which repair parts and service is readily available to the County from local vendors. The County shall not be bound to an exclusive vendor for repair, maintenance or material procurement for the system or its components.
5. Fire alarm devices vary widely in their electrical characteristics and must be carefully matched with suitable control panel to assure proper performance. Fire alarm devices, control panel and annunciator panel must be from the same manufacturer.
6. All fire alarm devices shall be readily accessible for testing, repair and maintenance purposes. All fire alarm devices located above a suspended ceiling must be clearly labeled as such on the ceiling. An LED light must be provided at the ceiling to show annunciation of that device, and access must be provided through the ceiling.
7. Smoke detectors shall not be located adjacent to or within three feet of supply or return air vents/diffusers.

8. Smoke detectors shall be provided in accordance with NFPA 72 and the applicable text and tables. Avoid specifying and locating smoke detectors in addition to that required by Code.
9. The contractor shall be required to provide the County with replacement initiation devices and audio-visual devices, equaling 10 percent of the total number of installed devices but not less than one of each type device, within seven days of Substantial Completion.
10. The specifications shall require that the contractor notify the Owner (Project Engineer to coordinate with FMD) at least 7 days in advance of the final complete test of the entire system to witness the testing prior to the acceptance by the County. Testing shall consist of, at a minimum: smoke and alarm, each smoke and duct detector, pull and reset, each pull station. Specifications shall require that the Contractor provide a complete overview of the system at the time of this system test.
11. The installer shall maintain the color-coding established by the manufacturer throughout the system. The terminations or connections in the control panels or junction points shall be clearly marked and the corresponding field wiring shall be permanently tagged.
12. Two dedicated telephone outlets are required for each auto-dialer. A jack shall be provided for each line to facilitate maintenance and testing.
13. Auto-dialer program and format codes shall be transmitted to Owner at the Substantial Completion walk-through, and a copy shall be included in the operations manual for the fire alarm system.
14. An auto-dialer shall be provided and connected to support the Fire Alarm Control Panel (FACP). The auto-dialer, which serves the FACP, shall not serve any other equipment.
15. The auto-dialer for the fire alarm shall be connected to the County's contracted monitoring service as directed by the Owner.
16. The auto-dialer, which serves the security system, shall not serve other equipment.
17. Facilities with an elevator shall be provided with an auto-dialer for the elevator, connected to the emergency phones in the elevator cabs and elevator lobbies. The auto-dialer shall connect to the County's contracted monitoring service as directed by the Owner.
18. The FACP, the Fire Alarm Annunciator Panel, and auto-dialer shall be programmed to automatically reset once a trouble or fault is cleared, as required by the Fairfax County Fire Marshall.

19. The auto-dialer for the Fire Alarm system and the elevator emergency phones shall have manual onsite reset capabilities, and shall automatically reset once the trouble or phone line or power interruption has cleared.
20. The auto-dialers shall automatically restore and or reset upon power or phone line interruption, once the power or the phone line restores and or stabilizes.
21. The auto-dialers shall be programmed to monitor/report events as required by the Fairfax County Fire Marshall's office. These events shall be sent via the dedicated phone lines to the County's contracted monitoring company as directed by the Owner.
22. The auto-dialer test timer test shall be programmed to perform between 7:00 A.M. and 1:00 P.M.
23. The contractor shall be required to arrange to receive and respond to all trouble and alarms received by the County's monitoring service prior to building occupancy by the County.
24. Duct detectors shall be programmed for Supervisory alarm as required by code.
25. Shelters and drug treatment facilities sleeping quarter's smoke detectors shall be programmed for Supervisory alarm as required by code.
26. The contractor shall transmit a copy of the Fire Marshall's final inspection report to the owner for transmittal to FMD prior to building occupancy by the County.
27. A key box is required by the Fire Marshall's office for the Fire and Rescue Department key access to buildings. See <http://www.fairfaxcounty.gov/fr/prevention/fmpublications/crp2009.pdf> Exhibit 08000A. The contractor shall coordinate with the Fire Marshall's office for the location and provide and install all required key boxes.
28. A/E shall obtain the most current copy of the Code Reference Package (CRP) for Architects, Engineers, Designers and Installers from the Fairfax County Fire & Rescue Department, Fire Prevention Division, Engineering Plans Review Section, and shall incorporate all requirements CRP into the design documents. All requirements of the CRP which are intended to be the responsibility of the Contractor shall be clearly identified as such in the contract documents.
29. Specifications shall clearly state that the Contractor is responsible for paying for all shop drawings, review fees, and permit fee associated with the review, approval and permitting necessary for a complete fire alarm system. The Contractor shall also pay any additional costs for Fire Marshall's inspections beyond those paid for by the Owner as part of the building permit and inspection fees.

30. All FACP auto-dialers shall have external surge suppression to protect the systems from lightning and voltage surges both from the line voltage and the phone lines. The surge suppression shall be in addition to the manufacturer's built-in suppression system. The surge suppression shall be installed and located adjacent to the FACP and the auto-dialer. A separate surge suppressor shall be installed for each of the FACP's and the auto-dialers.
31. Warranty for Fire Alarm Systems, shall be the system manufacturer's standard warranty (one year minimum), with options to purchase additional coverage.
32. Owner training (4 hours) for the Fire Alarm Systems shall be conducted by a certified training instructor provided by the manufacturer and shall be provided on-site after startup, and final Fire Marshall's inspections are completed and accepted.
33. Provide access panels to duct detectors for routine service and testing in a readily accessible and safely serviceable location. The access panel shall be located to allow for clear access with no obstructions such as, ducts, conduits, pipes or wires. The use of removable fixtures is not acceptable for access.
34. Fire Alarm System maintenance servicing tools (device programmer/diagnostic tool, interface devices etc.) shall be provided by the installer and shall be transmitted to the Owner for use in servicing, testing and maintaining the systems.
35. The contractor shall be responsible for all Fire Alarm System service and trouble calls on the equipment during normal and after normal work hours with a maximum response time of two hours, until the system is turned over and accepted by the Owner.
36. A plan of the fire alarm initiating devices and the corresponding device address shall be provided and installed adjacent to the FACP. These locations shall also be shown on the as-built floor plans for the fire alarm system. A copy of this plan shall be included in the Fire Alarm Systems O&M Manual.
37. Automatic HVAC shut down shall occur during fire alarm when alarm is initiated by automatic devices. HVAC shall not shut down if there is a manual trip of the alarm.
38. Provide interface wiring and conduit connection between fire alarm control panel and the remote generator alarm panel. Program Fire Alarm Control Panel to annunciate generator status alarms and have ability to connect into the County EDGAR system.
39. Fire alarm wiring protection for new critical operation facilities shall comply with NEC 708.14.

G. Lighting

1. Lighting shall be designed for the foot candle levels per the table listed in paragraph 16 below with task lighting provided to supplement where higher levels are desired. All fluorescent lights shall be provided with 32-watt T-8 lamps and electronic ballasts. Recommended light fixtures are: 2 x 4 lay-in with parabolic louvers, three lamps (277 volts). An acceptable alternate lighting fixture and source shall be LED lamps and fixtures. Outdoor LED fixtures shall have a color temperature of 5010°K, indoor 2750°K. Lumen output shall not occur by overdriving LED lamps to produce high Lumen ratings. Lighting loads shall comply with the requirements of the latest revision of International Energy Conservation Code. Electrical Energy Certification Form at http://www.fairfaxcounty.gov/dpwes/forms/elec_eng_comp.pdf. Exhibit 16000 A shall be completed and reviewed by the FMD Project Manager before submission to the County with Permit set submission.
2. Light fixtures used as HVAC diffusers are not acceptable.
3. Lighting in atrium areas, libraries or other high ceiling areas should utilize HID, Induction, or LED fixtures with remote drivers located in a-properly vented area. Ready access to all light fixtures is essential to properly maintain the designed lighting levels. Fixtures in high ceiling areas such as libraries shall be accessible from a ten-foot stepladder. Fixtures should be laid out so that it does not require the use of specialized personnel lifts with articulating booms or build up scaffolding. Fixtures that are not readily accessible are not acceptable.
4. The use of incandescent fixtures is prohibited except when specifically approved by the County FMD Project Manager. Where practical, lamps should be a common stock item standardized so that bulbs need not be special ordered.
5. Dimming systems shall be compatible with the BAS in place and also communicate with existing systems in the facility. All new or replacement dimming systems must receive prior approval by FMD. Automatic dimming systems should be utilized in areas where "daylight" may provide all or most of the required light level. Coordinate with FMD County Project Manager for prior approval of any proposed dimming system when using energy conserving lighting systems.
6. Decorative, accent and neon lighting should not be used, without specific approval from County Project Manager and FMD.
7. All exterior lighting should be controlled by photocell controls. The lighting controls, clocks and photocell controls should be located in the main electrical room. Parking lot lighting may be provided and maintained by the local utility. Coordinate with the County Project Manager prior to selection. Outdoor walkway lighting will be provided and maintained by the Owner and included as part of the design documents. Bollard type fixtures should not be used because they are a constant maintenance

liability due to vandalism. The use of outdoor, in-ground lighting is discouraged due to vandalism. Plans must show Contractor provided conduit for all site lighting circuits. The use of UF cabling for exterior lighting is not acceptable. All circuits for exterior lighting shall be routed in conduit.

8. Provide a small mulch bed installed around in ground light fixtures such as flag poles or building sign lights such that a lawn mower will not come into contact with the fixture head.
9. The mechanical and the electrical room lighting shall be on the standby emergency generator.
10. Where appropriate, the fuel site lighting and the power shall be on the emergency generator.
11. Lighting fixtures with battery backup, fluorescent or LED back up are not acceptable. Where buildings are served by Emergency Generators battery backup lights shall not be permitted. Facilities not served by Emergency or Standby Generators shall be provided with dual head battery pack flood type fixtures for ease of maintenance.
12. In libraries where stack lighting is accepted for use by Owner to be used, locate the lights where they are accessible for maintenance or repairs.
13. Where low voltage controls are incorporated for local switching, a layout of the relays should be permanently placed in the facility's main electrical room and panels and circuits should be clearly identified.
14. Separate emergency lighting control panels for the emergency lighting circuits shall be provided. These panels shall be painted red for easy identification and maintenance.
15. Fire station hose towers should be properly illuminated for safe use for storage. The fixtures shall be water tight and accessible for repairs.
16. Day lighting or indoor electrical illumination should comply with ANSI/IESNA RP-1-04. These values may need to be modified to suit the specific application in each facility.
 - a. Corridors 5 foot candles
 - b. Lobbies 10 foot candles
 - c. Means of Egress 20 foot candles
 - d. Storage Area 10 foot candles
 - e. Waiting Rooms & Lounge Areas 10 foot candles
 - f. General Office Areas 50 foot candles
 - g. Desktops 50 foot candles
 - h. Conference Tables 30 foot candles

- i. Secretarial Desks 50 foot candles
- j. Filing Cabinets 50 foot candles
- k. Book Shelves 50 foot candles
- l. Drafting 30 foot candles

Public Spaces:

- m. Library Reference Areas 50 foot candles
 - n. Library Reading Areas 50 foot candles
 - o. Auditoriums 30 foot candles
 - p. Cafeterias 30 foot candles
 - q. Parking Structures 1-5 foot candles (depending on level of use and security. Review with the County Project Manager.)
17. Lighting in high bay areas such as garages, gymnasiums or warehouses should use pendant type Induction, HID, or LED fixtures and should be easily removable for repair or replacement. Cord and plug connected is preferred. Safety chains must be provided on each fixture. Where Emergency Generators supply the power provide LED fixtures for instantaneous illumination in accordance with Life Safety Code requirements for emergency egress
 18. The A/E shall coordinate with the County Project Manager prior to selection of the site lighting. The site lighting may be provided and installed by the general contractor using Fairfax County approved site lights or by Dominion Virginia Power (DVP) under DVP and NOVEC Municipal Street Lighting contract. Subject to advance approval by the Owner, Contractor installed Induction or Light Emitting Diode (LED) site lighting fixtures may be specified, however, LED lights are preferred. See Products section for more details. The lights are to be used on small to medium size parking lots where cobra-head type fixtures are not appropriate and appropriate types and sizes of fixtures may not be available thru DVP.
 19. Occupancy Sensors shall be installed in areas of non-continuous lighting requirements, such as parking garages (dependent on security requirements), warehouses, conference rooms, offices, rest rooms, data centers, cafeterias, etc.
 20. Provide occupancy sensors in parking garages and parking lots where time clock off feature is used for general occupancy.
 21. In facilities that do not operate 24/7, the lighting levels must be reduced after the facility closing hours, to meet the Fairfax County Zoning Ordinance Performance Standards, required for parking lots and top deck of parking structures. The A/E shall specify photocell and appropriate equipment to comply with the Zoning Ordinance.
 22. All site and open garage lighting shall be provided with full cut-off to limit lighting to the property lines. Exterior lighting fixtures shall have glass lenses, plastic acrylic are

not acceptable as these degrade the light output by becoming yellow and are a maintenance burden.

23. Exterior building and walkway lighting not installed and maintained by DVP must be durable and vandal resistant. Metal bollard fixtures are not acceptable.
24. All wall mounted lighting control switches (and other similar wall mounted control switches) shall be toggle type switches. Rocker type switches for energy saving lighting control systems is acceptable.
25. Provide occupancy sensors to automatically shut off lights for offices, conference rooms, storage rooms, gymnasiums, and other appropriate spaces. Coordinate with the owner/occupier for specific rooms in a given building. The occupancy sensor must be located in an appropriate location for optimum operation.
26. Emergency Exit lights shall be LED type.
27. Track lights, Mono, Twin Rail, Low Voltage Decorative lights are a high maintenance item and should be avoided and provided only if absolutely necessary.
28. Remote ballasts should be grouped in a space with sufficient size and ventilation to support the equipment and shall be readily accessible for maintenance purposes. Remote Ballasts located above ceilings requiring ladder access are not considered readily accessible.
29. Provide interface and connect lighting control panels to BAS. BAS shall provide master programming for lighting controls.

H. Lightning Protection Integrated with the Main Grounding System

1. Lightning protection system is not a requirement for every facility. A risk analysis shall be conducted per NFPA 780 to verify the level of risk. The results of this analysis shall be provided to the Owner in the design narrative. The decision to include the lightning protection system shall be made based on the risk level and cost.
2. Direct contractor to submit detailed as-built drawings for the lightning protection system with UL certification. As-built drawings must show down-lead locations, conductor routing and conductor connections sites. A copy of the UL Master Label certification of the lightning protection system must be included in the O&M manuals. Provide a bond for the lightning protection system with the main grounding grid or main grounding bar.
3. Require contractor to also provide as-built drawings for the building grounding system including rod sizes, locations, and configuration and connection details.

4. Specifications shall require that the contractor obtain a UL certification for the grounding system and submit a copy of the certificate to the Architect/Engineer and FMD for review and approval before final submission to the Owner.

I. Telecommunications Guidelines:

1. Refer to Appendix B.

II. PRODUCTS

A. Electrical Main Services

1. Main distribution panels, sub panels and disconnects shall be Cutler Hammer, Square D or Siemens. FPE and Challenger are not acceptable. Cutler Hammer CH- PRL1a panels are preferred with bolt in breakers. The type PB panels give flexibility by accepting both bolt-in and push-in breakers. Provide one stock circuit breaker for each type installed.
2. The use of aluminum cable is unacceptable. Provide only copper cable. All branch circuits and feeder conductors #6 and larger shall have manufacturer applied phasing color for full length. (SIM PULL by South Wire manufacturer as a reference). Use of phase colored tape is not acceptable.
3. Motor Control Centers: Square D, General Electric, or Siemens. The use of motor control centers shall be approved in writing by FMD and Project Manager.

B. Wiring Systems

1. Where a floor wiring system is required, a walker duct type floor system with separate trough for electrical, computer and communication wiring is recommended. Flat wire systems are not desirable and shall not be included in the design without prior approval of the County Project Manager (flat wiring must be approved in writing by the Telecommunications Division of the Department of Information Technology).

C. Emergency & Standby Generator and Automatic Transfer Switch Set

1. The acceptable manufacturers for emergency standby generators are: MTU Onsite Energy, Generac, Cummins and Caterpillar.
2. The use of a Detroit V-12 engine is not acceptable.
3. Automatic transfer switch manufacturers shall be Zenith, ASCO, Cummins (no equal products).

4. All new transfer switches shall be isolation and bypass type to facilitate easier maintenance and online reliability.

D. Fire Alarm System

1. Manufacturers for fire alarm devices, control panels, and annunciator shall be Silent Knight 5820 XL or other non proprietary system. Only listed graphic fire alarm annunciator panels (IEC; NFPA 72A 1-2.2) are to be installed. All fire alarm devices connected to the Fire Annunciator Control Panel (FACP) shall be by the manufacturer of the FACP.

E. Site Lighting

1. Metal Halide Lights, Induction, or LED lamp (Verify with the FMD County Project Manager for most current models)
 - a. Manufacturer: Holophane (www.holophane.com)
 - b. Model: Mongoose,
<http://www.holophane.com/products/Family.asp?Brand=HLP&Family=Mongoose&ProductType=Outdoor&Category=designer&SubCategory=Contemporary> Or www.Holophane.com/products (look for Contemporary, select Mongoose).
 - c. Lamp Type: 175 Watts Metal Halide, medium base
 - d. Mounting: 20' square steel posts in parking lot, 14' poles immediately adjacent to the building.
 - e. Pole and Fixture color: Squat steel pole, grey pole and fixture
 - f. Voltage: 277
2. LED Lights (Verify with the FMD County Project Manager for most current manufacturers and models)
 - a. Manufacturer: Elumen (www.elumen.ca)
 - b. Model: LED-SL-100WX-A-W-3-22-5, ARM 7",
http://www.elumen.ca/index.php?option=com_content&view=article&id=11&Itemid=38&lang=en
 - c. Lamp Type: LED, Medium base
 - d. Mounting Height: 20' at parking lot, direct mounted.
 - e. Poles: SA-20-400-C3AB-IDR series.
 - f. Pole and Fixture color: Squat steel pole, grey pole and fixture
 - g. Voltage: 277
3. LED Lights-Decorative (Verify with the FMD County Project Manager for most current models)
 - a. Manufacturer: Holophane (www.holophane.com)
 - b. Model: WFL/Washington Postlite
 - c. Lamp Type: 100 W LED

- d. Mounting Height: 20' Base Mounted.
- e. Pole and Fixture color: Black
- f. Voltage: 120 Volts
- g. Optics Specified: Asymmetric full cutoff flat glass
- h. Ball Finial

VOLTAGE: 208/120V
 BUS: 200A
 MAIN: MLO

3 PHASE, 4 WIRE
 LOCATION:
 FED FROM:
 SECTION: 1 OF 1

PANEL:

AIC: 22,000
 MOUNTING: SURFACE
 SOURCE: NORMAL

LOAD TYPE	LOAD DESCRIPTION	FDR SIZE (KVA)	BKR (A)	CKT NO	LOAD (KVA)			CKT NO	BKR (A)	LOAD (KVA)	FDR SIZE	LOAD DESCRIPTION	LOAD TYPE
					A	B	C						
N				1	0.0			2				N	
N				3		0.0		4				N	
N				5			0.0	6				N	
N				7	0.0			8				N	
N				9		0.0		10				N	
N				11			0.0	12				N	
N				13	0.0			14				N	
N				15		0.0		16				N	
N				17			0.0	18				N	
N				19	0.0			20				N	
N				21		0.0		22				N	
N				23			0.0	24				N	
N				25	0.0			26				N	
N				27		0.0		28				N	
N				29			0.0	30				N	
N				31	0.0			32				N	
N				33		0.0		34				N	
N				35			0.0	36				N	
N				37	0.0			38				N	
N				39		0.0		40				N	
N				41			0.0	42				N	

Notes:

-
-
-

KVA/PHASE: 0.0 0.0 0.0

(KVA) (AMP): 0.0 0 0

TOTAL CONNECTED: 0.0 0 0

PANELBOARD SPECIAL FEATURES

SURGE PROTECTION DEVICE (SPD)

OTHER

FEEDER SIZE:

1
2
3
4
5
6
7
R
X
E

LOAD TYPE CODE LETTERS

LOAD TYPE CODE LETTERS	(KVA)	(AMP)
C	CONTINUOUS LOAD (125% OF CONTINUOUS LOAD)	0.0 0
K6	KITCHEN DEVICES (SIX OR MORE AT 65% OF LOAD)	0.0 0
LM	LARGE MOTOR LOAD (LARGEST MOTOR x125%)	0.0 0
M	MOTOR LOAD (100% OF LOAD)	0.0 0
IM	INTERMITTENT MOTOR LOAD (85% OF LOAD)*	0.0 0
N	NON-CONTINUOUS LOAD (100% OF LOAD)**	0.0 0
R	RECEPTACLE LOAD (FIRST 10KVA AT 100%. REMAIN. AT 50%)	0.0 0
TOTAL DEMAND:		0.0 0

* FAIRFAX COUNTY @ (100% OF LOAD)

** REMAINING LOADS

RELOCATE EXISTING CIRCUIT
 REMOVE EXISTING CIRCUIT (CONDUIT AND WIRE)
 EXISTING CIRCUIT TO REMAIN

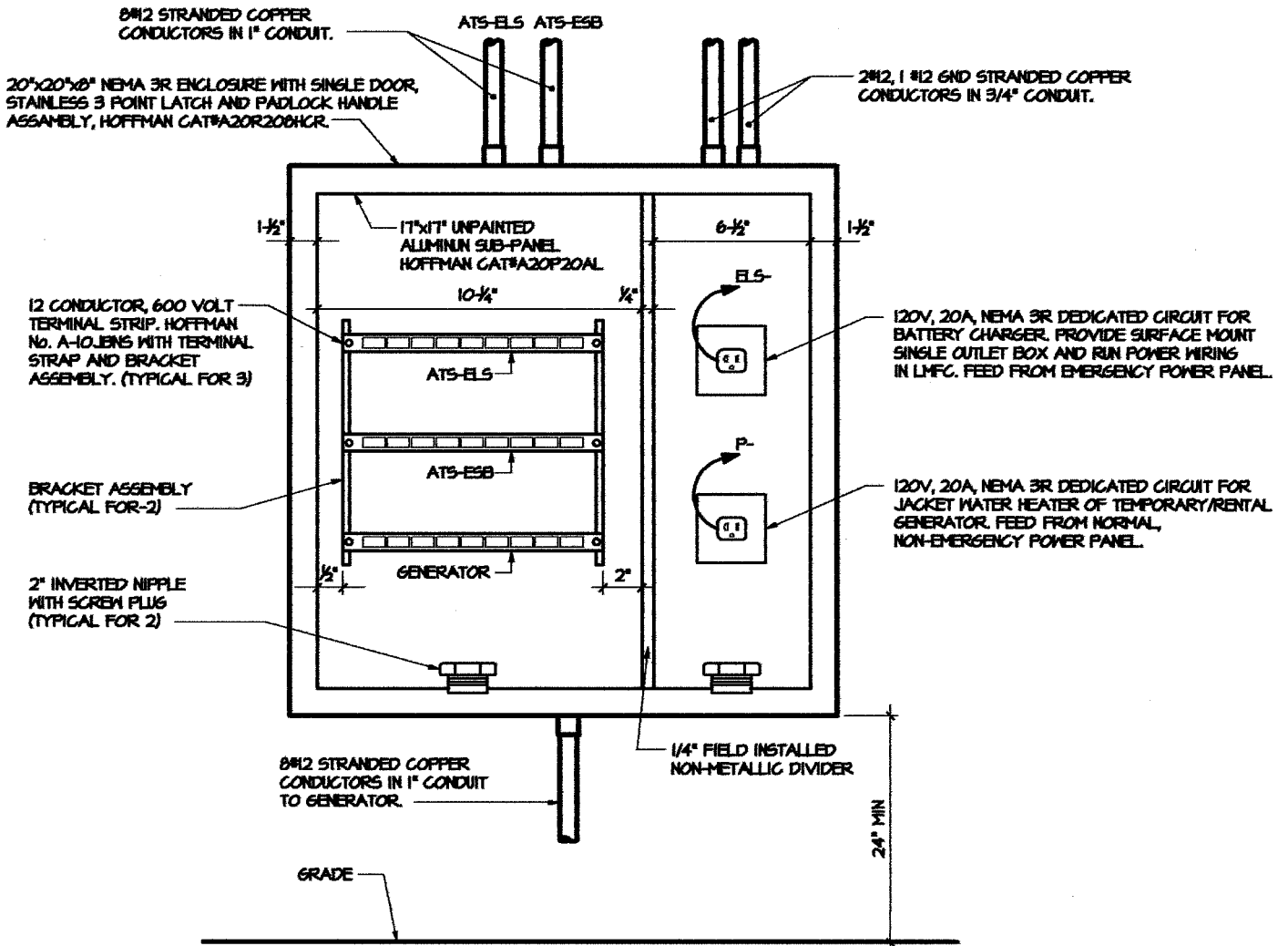

GENERATOR CONNECTION BOX
NOT TO SCALE

- 1 COORDINATE STUB-UP AND EQUIPMENT CONNECTION LOCATION FOR ALL UNDERGROUND FEEDERS WITH GENERATOR MANUFACTURER PRIOR TO ROUGH-IN. RUN CONDUITS ALL 24" BELOW FINISHED GRADE.
- 2 CONNECT POWER CONDUCTORS TO GENERATOR MAIN CIRCUIT BREAKER FROM RACK MOUNTED 3PDT DISCONNECT SWITCH WITH INVERTED NIPPLES. SEE RISER DIAGRAM FOR CONTINUATION, CONDUIT AND WIRE SIZES.
- 3 1" CONDUIT FROM GENERATOR GAP PANEL TO 15KVA XFMR VIA ENCLOSED CB.
- 4 EXTEND 1" CONDUIT WITH 12#12 AND 2C/TRS TWISTED PAIR ('BELDEN' #9413) FROM CONTROL PANEL TO REMOTE GENERATOR ANNUNCIATOR PANEL (RGAP).
- 5 1" CONDUIT WITH CONDUCTORS TO EXTERIOR WALL MOUNTED GENERATOR CONNECTION BOX AS REQUIRED TO PARALLEL GENERATOR REMOTE START AND STOP CONTROLS AT ATS-GEN. PROVIDE SCREW DOWN WIRING STRIP IN ENCLOSURE FOR PARALLEL CONNECTION OF ROLL-UP GENERATOR CONTROL WIRING.
- 6 4#20 IN 3/4" C FROM GENERATOR CONTROL PANEL TO DAY TANK FOR CONTROL.
- 7 #4/0 AWG BTC GROUND CONDUCTOR TO GROUND ROD. CADWELD CONDUCTORS TO GENERATOR FRAME AND GROUND ROD.
- 8 10' BY 3/4" STEEL COPPER CLAD GROUND BAR DRIVEN 36" BELOW GRADE AND CONNECTED TO GROUND ROD CONDUCTOR.
- 9 20'-1/0 BTC UFER GROUND GENERATOR TRANSFORMER FOUNDATION FOOTING.
- 10 EQUIPMENT RACK. SEE 4/E5 FOR DETAILS.
- 11 4#500+1#3G IN 3" C FROM GENERATOR TO DOUBLE THROW, CENTER OFF SWITCH.
- 12 3#6+1#10G IN 1" C FROM 200A FSS TO 'ATS-FP'.
- 13 4#1+1#6G IN 2" C FROM 100A FSS TO 'ATS-EHSB'.
- 14 EXTEND 4#250+1#4G IN 3" C FROM 400A FSS TO 'ATS-EHLS'.
- 15 1" CONDUIT WITH CONDUCTORS TO EXTERIOR WALL MOUNTED GENERATOR CONNECTION BOX AS REQUIRED TO PARALLEL GENERATOR REMOTE START AND STOP CONTROLS AT ATS-GEN. PROVIDE SCREW DOWN WIRING STRIP IN ENCLOSURE FOR PARALLEL CONNECTION OF ROLL-UP GENERATOR CONTROL WIRING.
- 16 WALL MOUNTED REMOTE MANUAL STOP STATION WIRED TO GENERATOR CONTROL PANEL TO PROVIDE EMERGENCY SHUT DOWN OF THE GENERATOR.
- 17 2#12+1#12G IN 1" C FROM GAP TO DAY TANK
- 18 2#12 IN 1" C FROM GENERATOR CONTROL PANEL TO DAY TANK

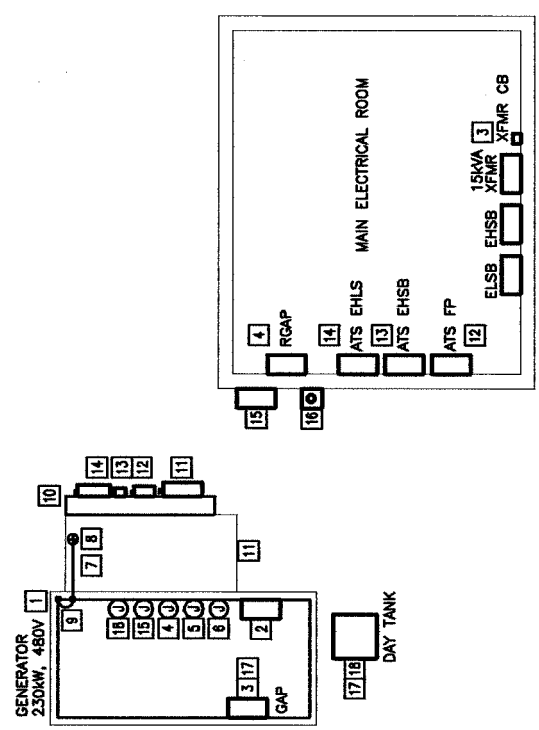

GENERATOR SCHEMATIC DETAIL
 EX NOT TO SCALE

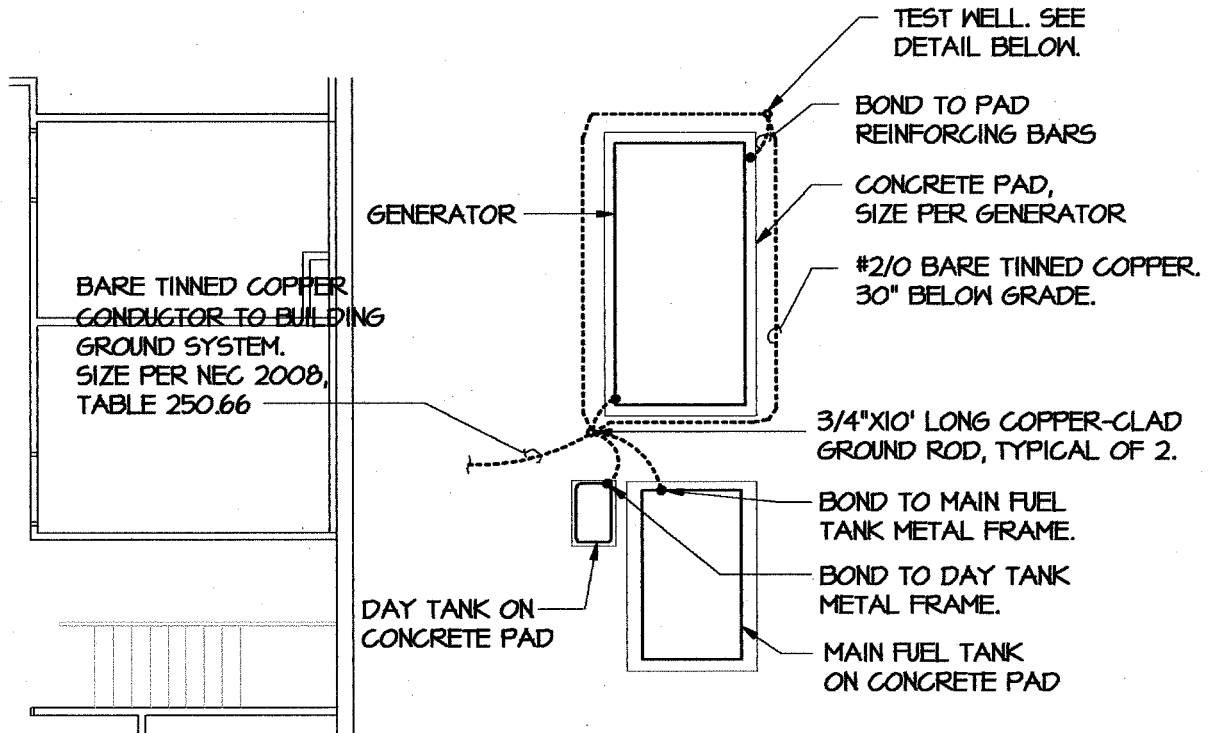

GENERATOR
GROUNDING DETAIL
NOT TO SCALE

NOTE: ALL EQUIPMENTS SHALL BE GROUNDED IN ACCORDANCE WITH THE NATIONAL ELECTRICAL CODE 2008 EDITION ARTICLE 250, GROUNDING AND BONDING.

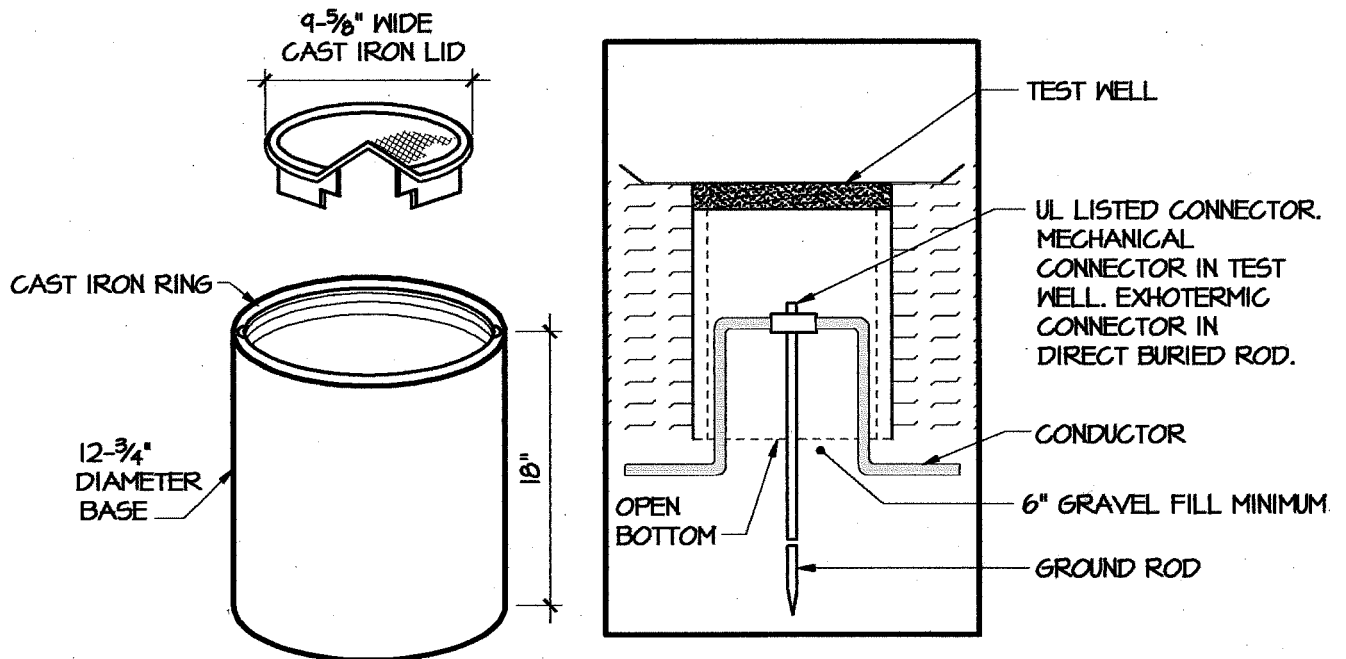

3/8" STEEL GROUND TEST WELL DETAIL

NTS