

Fairfax County, Virginia

Typical Retaining Wall Details

Based on the 2009 International Residential Code

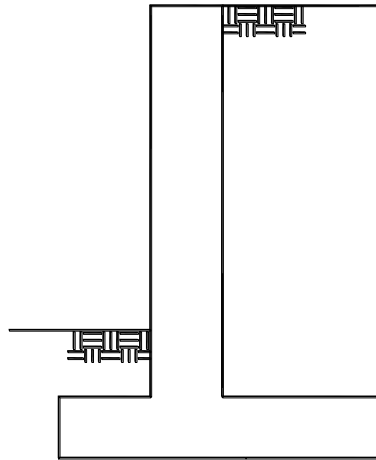

CONTENTS

Timber Retaining Wall	2
General Requirements	2
Wall Construction	2
Deadmen	3
Connections.....	3
Masonry Retaining Wall	4
General Requirements	4
Wall Construction	4
Bond Beam and Reinforcement Details.....	4
Dowels and Keyway.....	5
Vertical Joints	6
Backfill and Drainage.....	6
Concrete Retaining Wall	6
General Requirements	6
Wall Construction	6
Dowels and Keyway.....	8
Vertical Joints	8
Backfill and Drainage.....	8

This design document applies to residential non-tiered, non-stacked retaining walls with level backfill and no surcharge loading retaining no more than 4 feet of earth. Retaining walls must be constructed in conformance with the details contained herein. A copy of these details is required to be on the job site and available to the inspector during each required inspection.

TIMBER RETAINING WALLS

General Requirements

1. All lumber shall be 6x6, southern pine, grade #2 or better and pressure treated in accordance with American Wood-Preservers' Association standards for ground contact.
2. All spikes shall be 60d or equivalent, hot-dipped galvanized or stainless steel and driven into pre-drilled holes. Spikes shall be of sufficient length to penetrate the base member a minimum of 2 inches.
3. Member joints shall be staggered a minimum of 3.5 feet from the joints of the course above and below.

Wall Construction

The construction of a timber retaining wall shall conform to the requirements shown in FIGURE 1 through FIGURE 3.

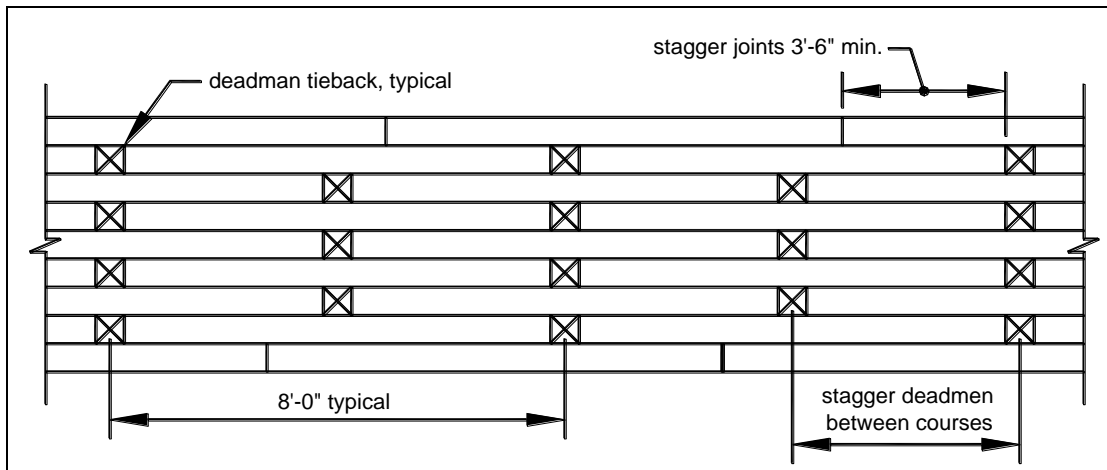

FIGURE 1: TYPICAL ELEVATION

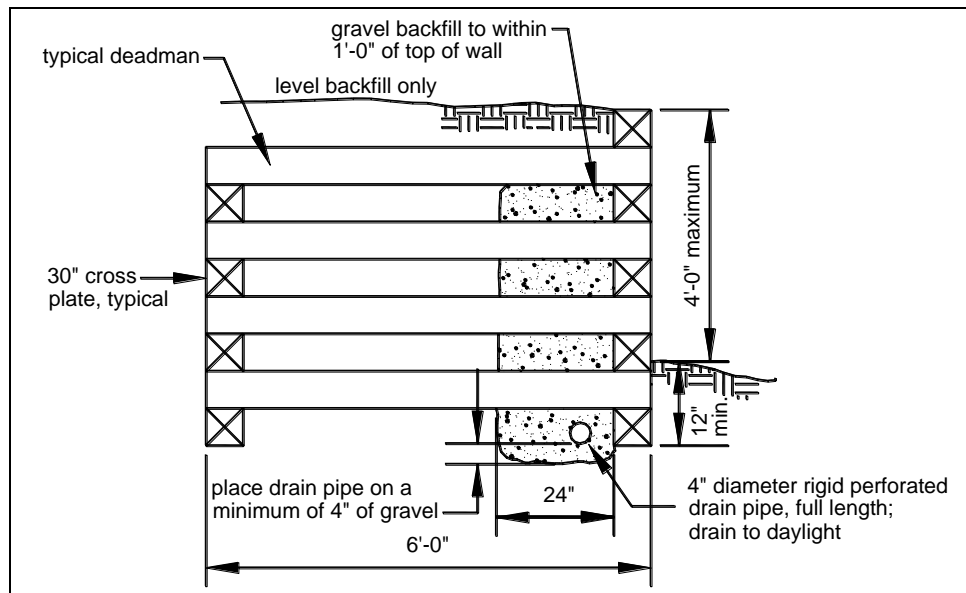

FIGURE 2: TYPICAL SECTION

Deadmen

Deadmen shall be placed at 8 feet on center as shown in FIGURE 1. Deadmen and cross plates shall be constructed as shown in FIGURE 3. Deadmen are not required in the bottom course below grade.

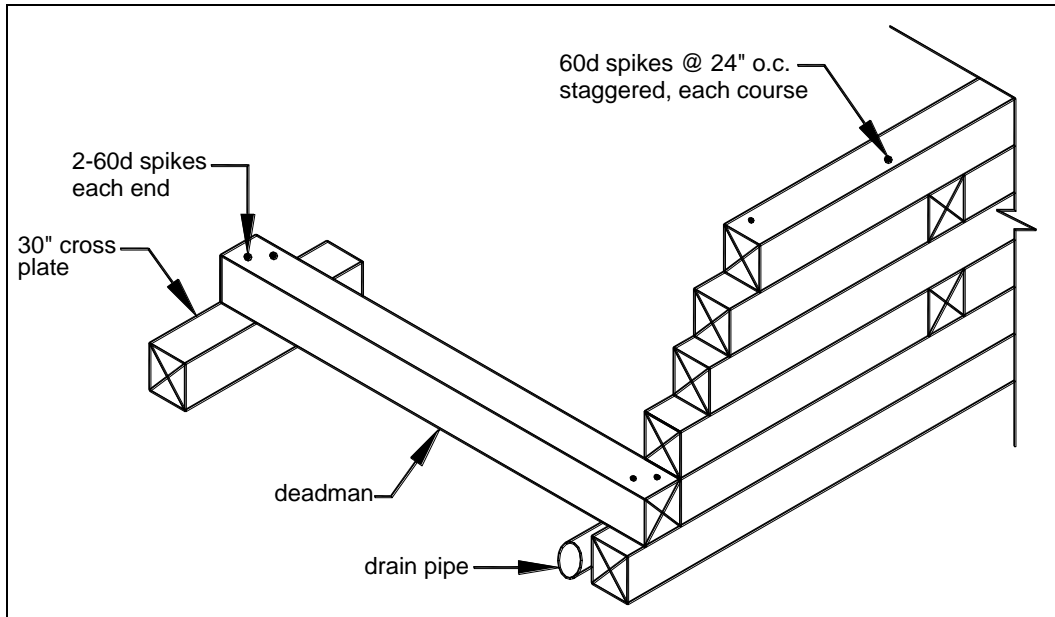

FIGURE 3: TYPICAL DEADMAN DETAIL

Connections

Each 6x6 member shall be secured at each end with 2-60d spikes driven vertically into the member below. The corners shall be secured with 2-60d spikes and driven horizontally as shown in FIGURE 4.

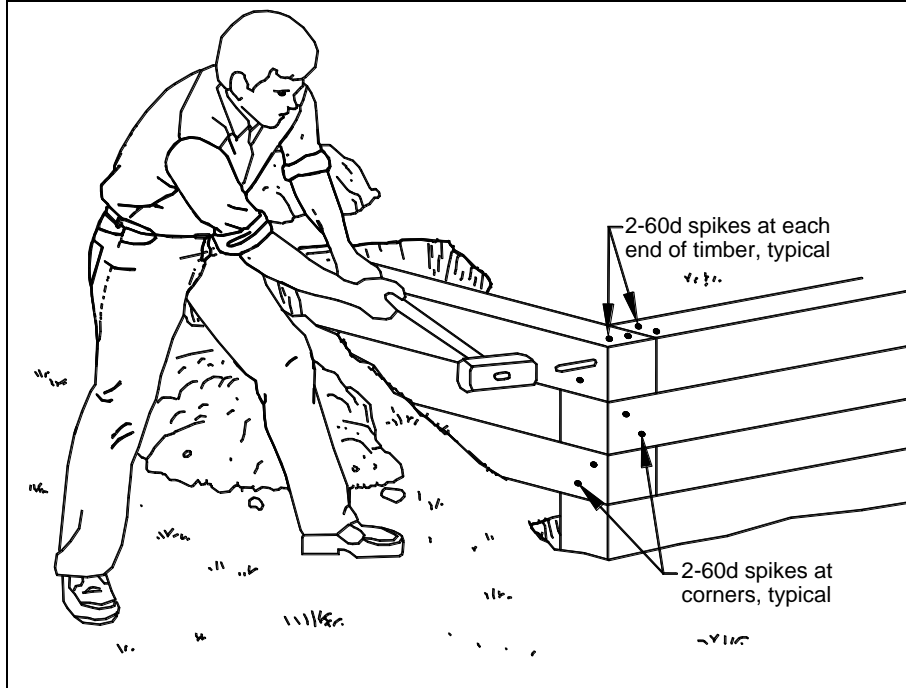

FIGURE 4: TYPICAL CORNER DETAIL

MASONRY RETAINING WALLS

General Requirements

1. The minimum concrete compressive strength at 28 days shall be 3,500 PSI and shall comply with ACI 318.
2. Reinforcing steel shall comply with ASTM A615 and shall have a yield strength of 60,000 PSI.
3. Concrete masonry blocks shall comply with ASTM C90.
4. All joint reinforcement, ties and other accessories shall be resistant to corrosion.
5. All head and bed joints shall be $\frac{3}{8}$ -inch thick. Bed joints of the starting course over the concrete foundation may be between $\frac{1}{4}$ -inch and $\frac{3}{4}$ -inch. Mortar shall conform to ASTM C270.

Wall Construction

The construction of a concrete masonry retaining wall shall conform to the dimensions and reinforcing steel requirements shown in FIGURE 5 and TABLE 1. O bars, or dowels, can be lapped above the footing in accordance with FIGURE 9.

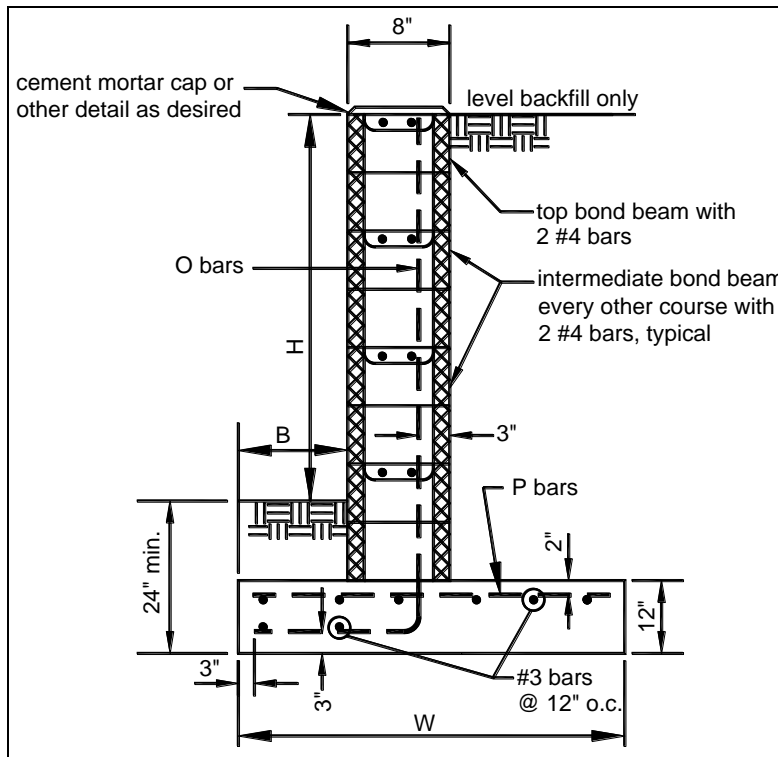

FIGURE 5: TYPICAL MASONRY WALL SECTION

TABLE 1: TYPICAL MASONRY WALL SPECIFICATIONS

H	B	W	O-bars (dowels)	P-bars
24"	12"	39"	#3@32"	#3@27"
36"	12"	39"	#4@32"	#3@27"
48"	12"	63"	#4@16"	#4@30"

Bond Beam And Reinforcement Details

A bond beam shall be provided at the top course and at intermediate courses below as shown in FIGURE 5. Bond beams shall be constructed using the block types shown in FIGURE 6. Vertical and horizontal steel placement shall be per FIGURE 7 and FIGURE 8.

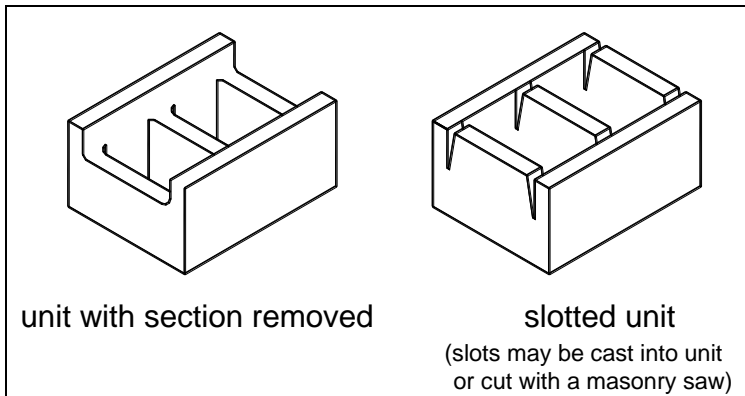

FIGURE 6: BOND BEAM BLOCK TYPE

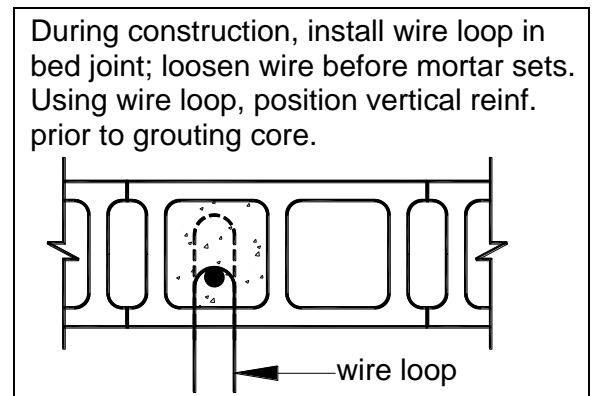

FIGURE 7: VERTICAL REINFORCEMENT TIE HOLD DETAIL

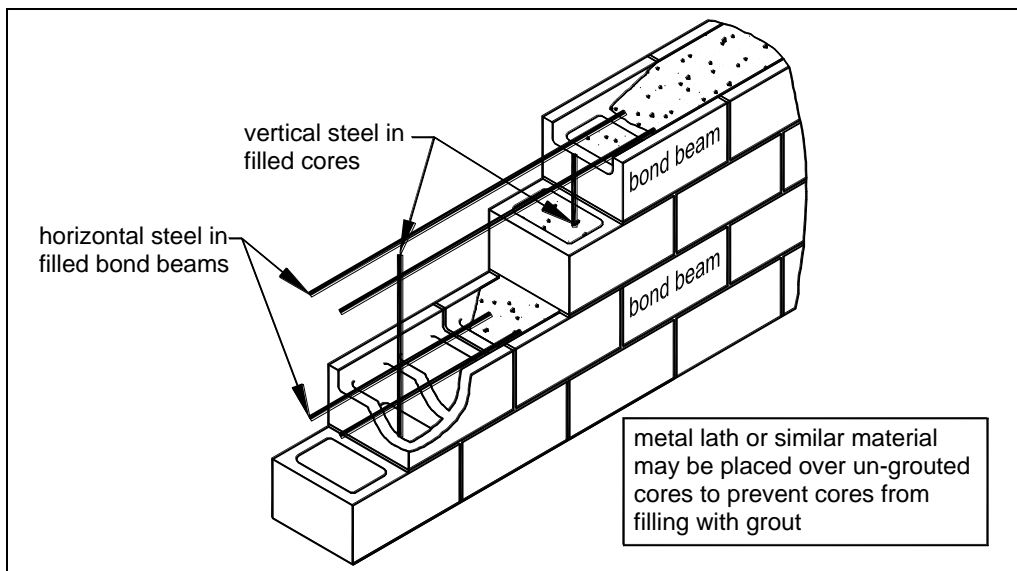

FIGURE 8: TYPICAL WALL REINFORCEMENT DETAIL

Dowels And Keyway

O bars, or dowels, can be lapped as shown in FIGURE 9. The minimum lap length shall be 15 inches for a #3 bar, 20 inches for a #4 bar, 25 inches for a #5 bar and 30 inches for a #6 bar. A keyway or roughened concrete shall be placed on the footing surface below the block wall; see FIGURE 9.

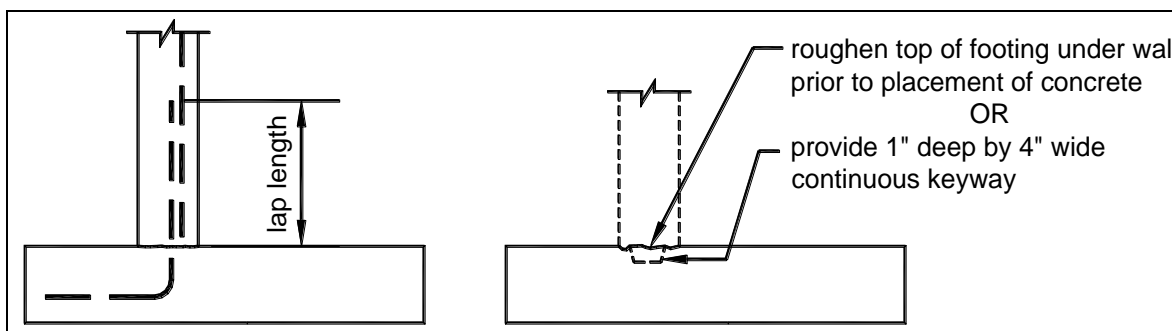

FIGURE 9: TYPICAL DOWEL AND KEYWAY DETAIL

Vertical Joint

Control joints, constructed per FIGURE 10, shall be placed no more than 20 feet on center. Expansion joints, constructed per FIGURE 11, shall be placed at every fourth control joint.

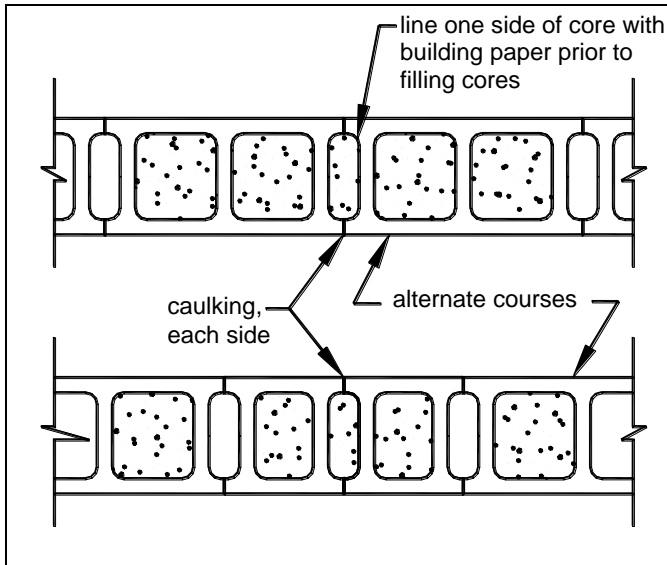

FIGURE 10: CONTROL JOINT DETAIL

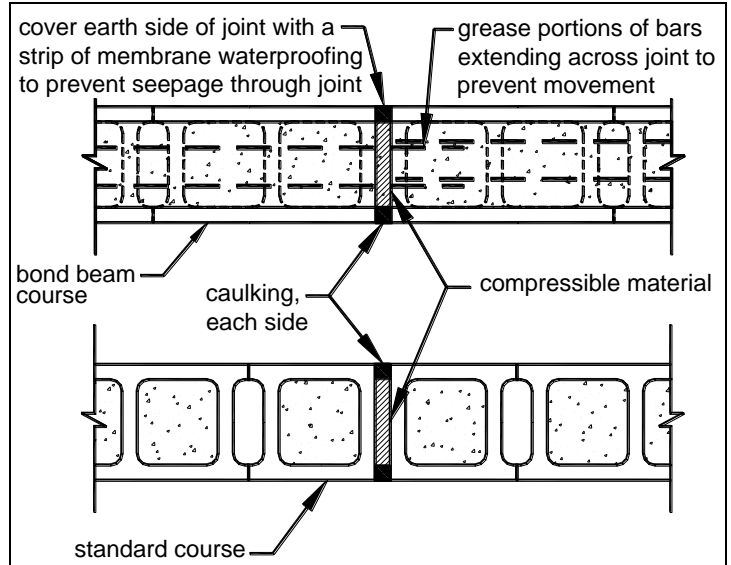

FIGURE 11: EXPANSION JOINT DETAIL

Backfill And Drainage

Backfilling against reinforced masonry retaining walls shall not be permitted until at least 7 days after placing concrete or grout in cores. Heavy equipment shall maintain a distance away from the wall equal to the wall's height. Care shall be taken to avoid exerting large impact forces on the wall.

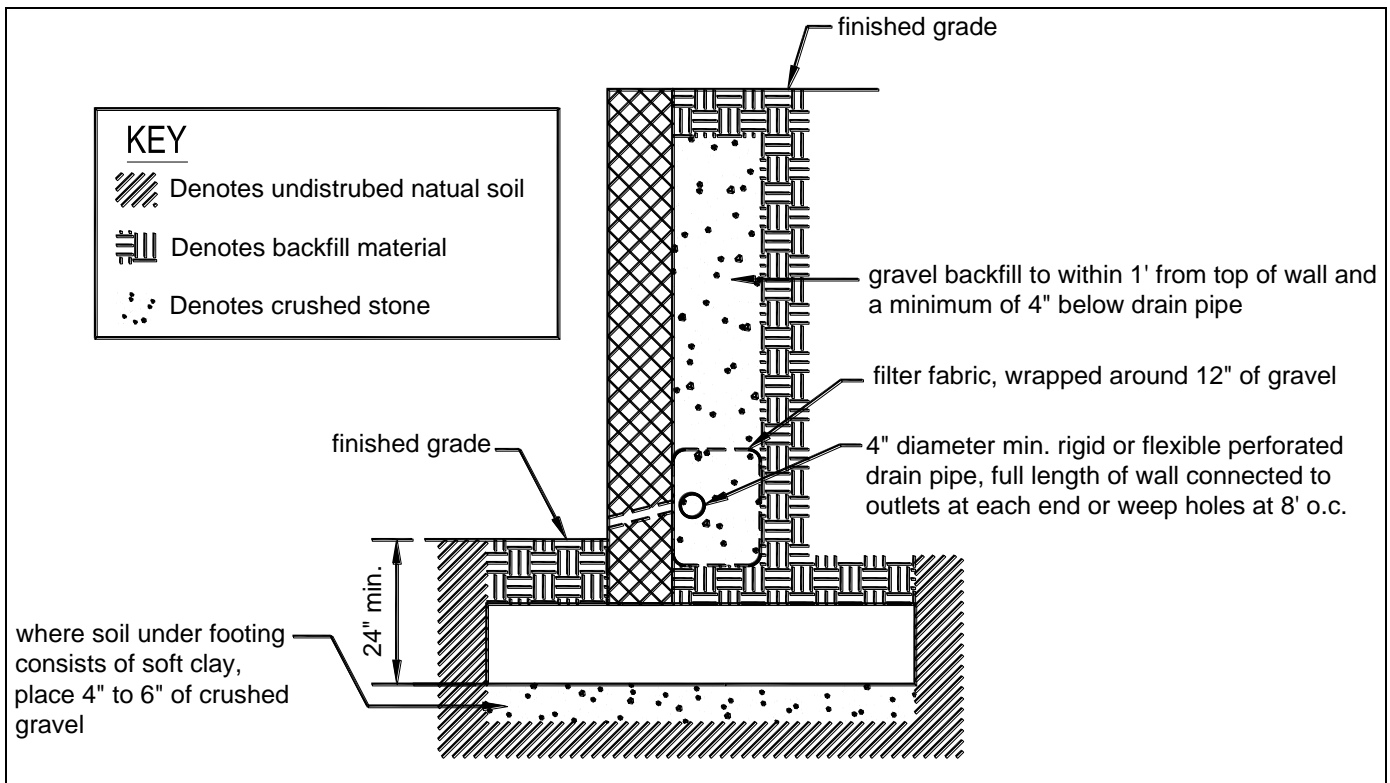

FIGURE 12: TYPICAL BACKFILL AND DRAINAGE DETAIL

CONCRETE RETAINING WALLS

General Requirements

1. The minimum concrete compressive strength at 28 days shall be 3,500 PSI and shall comply with ACI 318.
2. Reinforcing steel shall comply with ASTM A615 and shall have a yield strength of 60,000 PSI.

Wall Construction

The construction of a concrete retaining wall shall conform to the dimensions and reinforcing steel requirements shown in FIGURE 13 and TABLE 2. Dowels, can be lapped above the footing in accordance with FIGURE 14.

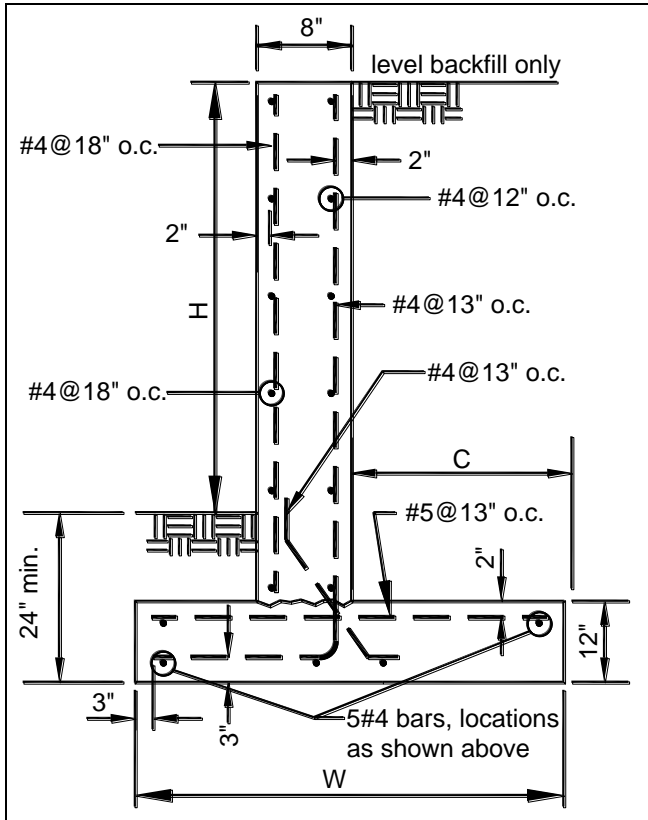

FIGURE 13: TYPICAL CONCRETE WALL SECTION

TABLE 2: TYPICAL CONCRETE WALL DIMENSIONS¹

H	C	W
24"	19"	39"
36"	28"	48"
48"	40"	60"

¹Reference: Concrete Reinforcing Steel Institute

Dowels And Keyway

Dowels, #4@13" o.c., must be lapped a minimum of 20 inches. A keyway or roughened concrete shall be placed on the footing surface below the block wall. See FIGURE 14.

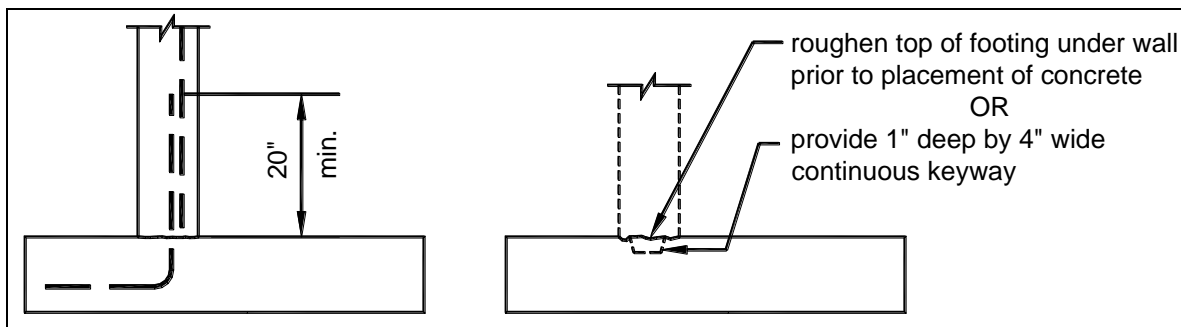

FIGURE 14: TYPICAL DOWEL AND KEYWAY DETAIL

Vertical Joint

Control joints, constructed per FIGURE 15, shall be placed no more than 20 feet on center. Expansion joints, constructed per FIGURE 16, shall be placed at every fourth control joint.

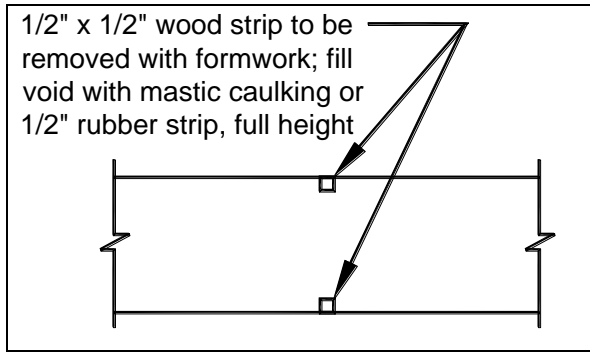

FIGURE 15: TYPICAL CONTROL JOINT

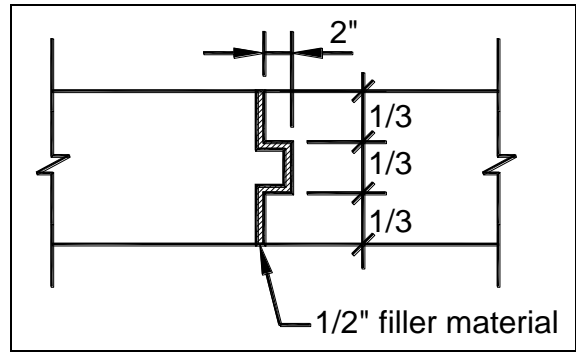

FIGURE 16: TYPICAL EXPANSION JOINT

Backfill And Drainage

Backfilling against reinforced concrete retaining walls shall not be permitted until the concrete has reached its 28-day strength. Heavy equipment shall maintain a distance away from the wall equal to the wall's height. Care shall be taken to avoid exerting large impact forces on the wall.

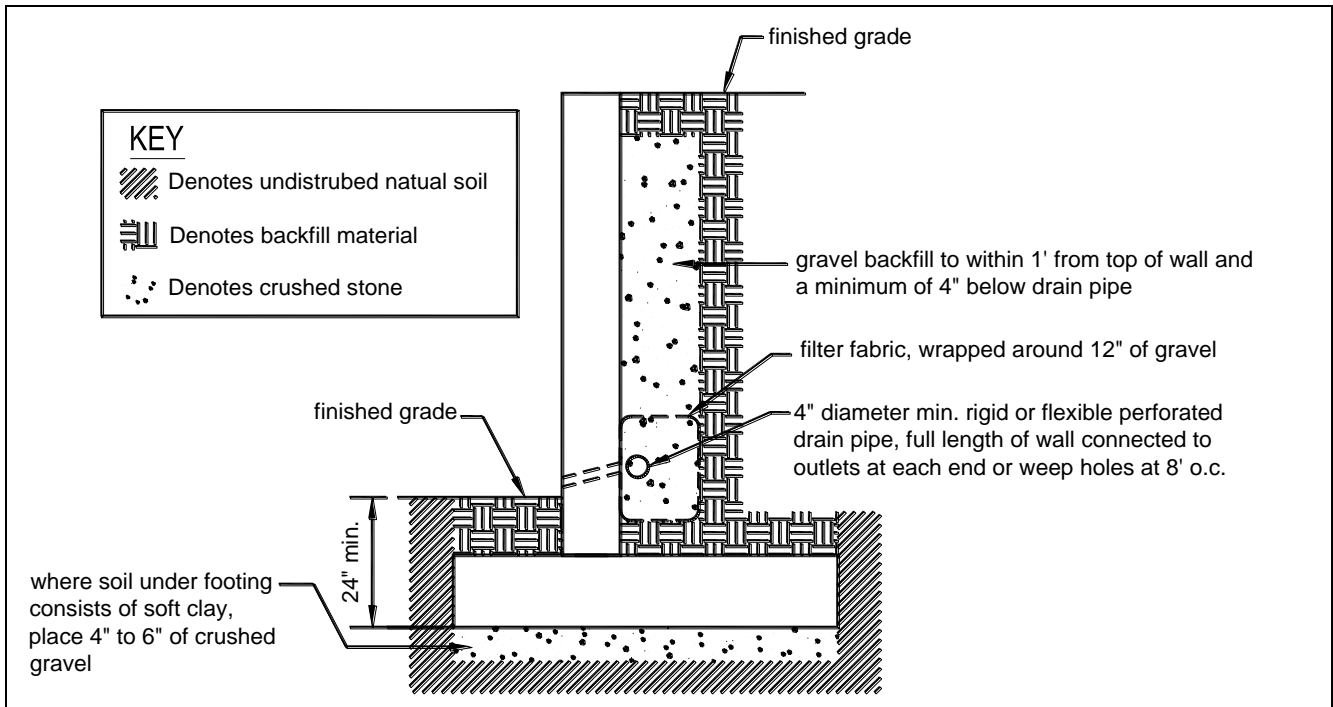

FIGURE 17: TYPICAL BACKFILL AND DRAINAGE DETAIL

Fairfax County is committed to a policy of nondiscrimination in all county programs, services and activities and will provide this document in alternative formats and in different languages upon request. Please call **703-324-5033, TTY 711** or write Department of Public Works and Environmental Services, Suite 659, 12055 Government Center Parkway, Fairfax, VA 22035-5506. Please allow at least seven working days for preparation of material.



A Fairfax County, Virginia Publication