

# Demographic Reports 1995

*Fairfax County, Virginia*

*A Report of the Urban Development Information System (UDIS)*

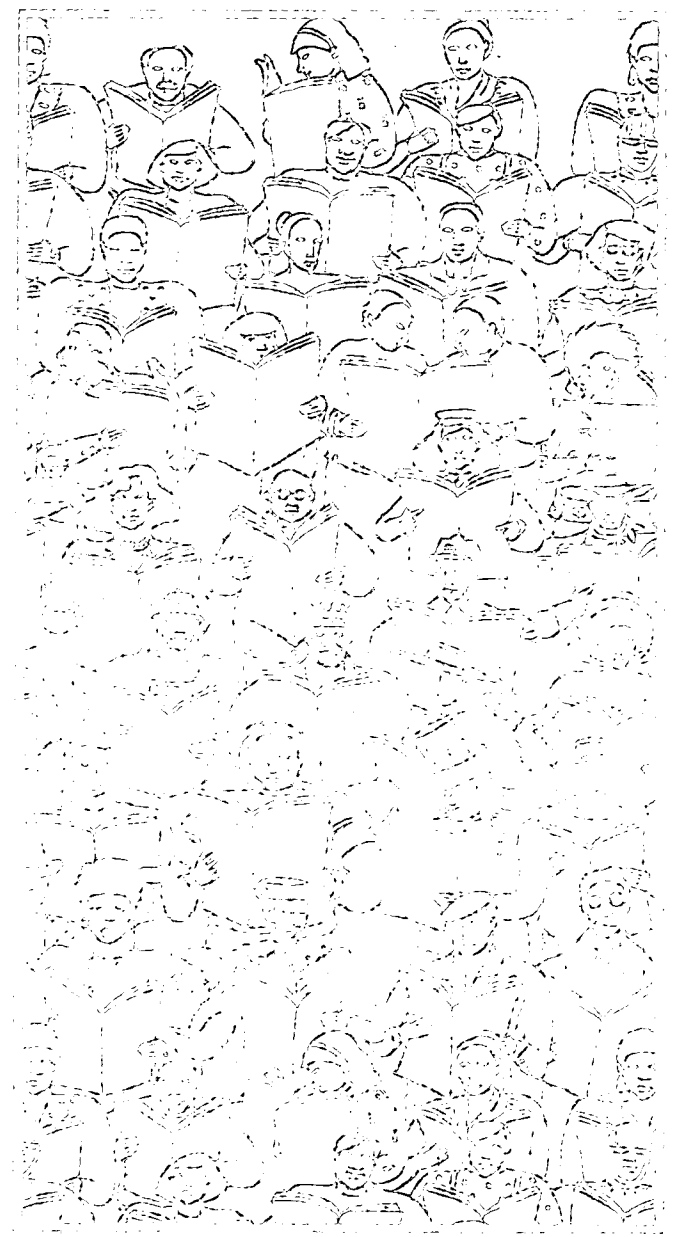
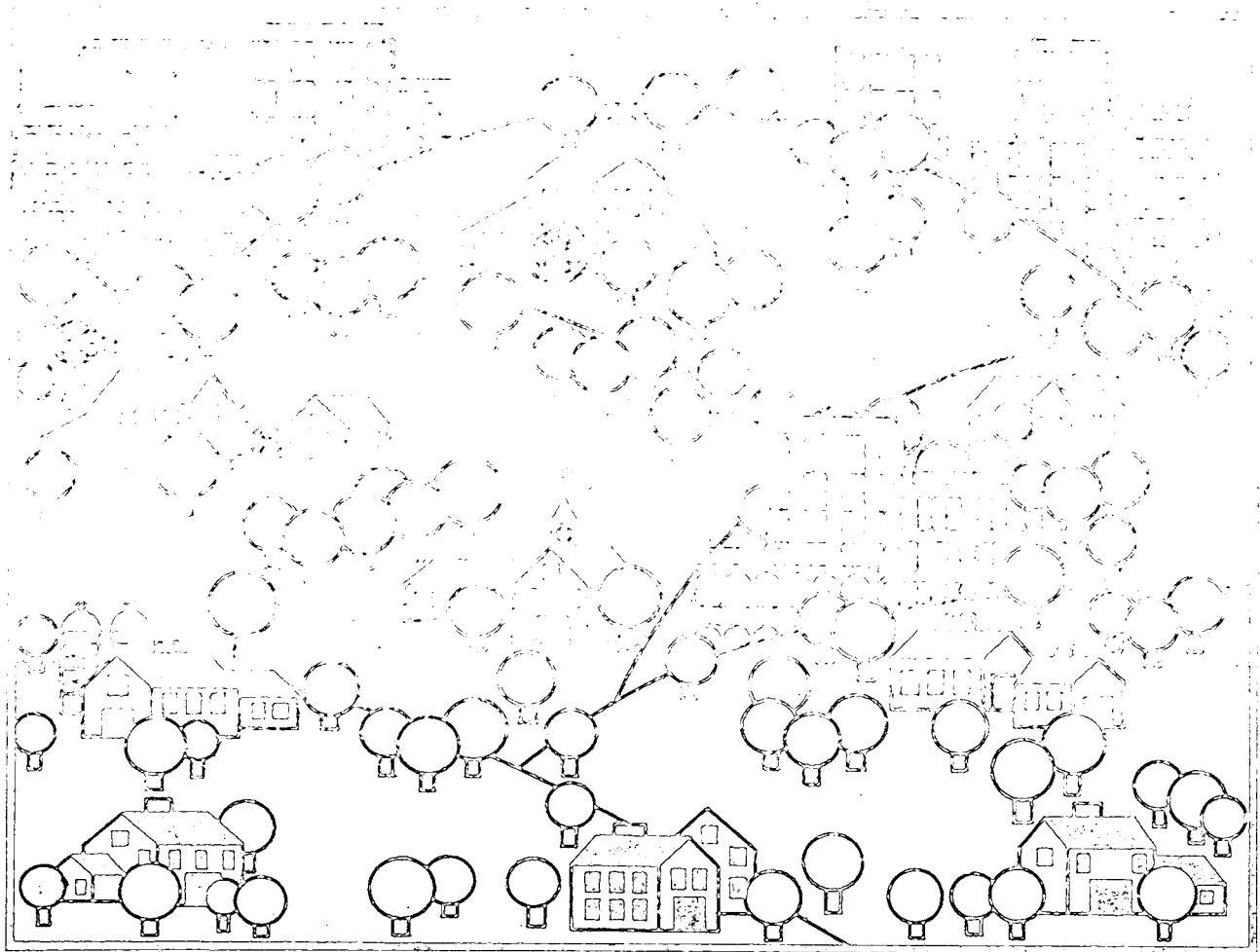

*Office of  
Management & Budget*

**FAIRFAX COUNTY BOARD OF SUPERVISORS**

**Katherine K. Hanley**  
*Chairman*

**Gerald W. Hyland**  
*Vice Chairman*  
*Mount Vernon District*

**Sharon Bulova**  
*Braddock District*

**Gerald E. Connolly**  
*Providence District*

**Robert B. Dix, Jr.**  
*Hunter Mill District*

**Michael R. Frey**  
*Sully District*

**Penelope A. Gross**  
*Mason District*

**Dana Kauffman**  
*Lee District*

**Elaine N. McConnell**  
*Springfield District*

**Stuart Mendelsohn**  
*Dranesville District*

**William J. Leidinger**  
*County Executive*

**James P. McDonald**  
*Deputy County Executive for*  
*Management & Budget*

**Edward L. Long, Jr.**  
*Director, Office of*  
*Management & Budget*

**Office of  
Management & Budget**

**Anne Pickford Cahill**  
**David L. Beavers, *Project Manager***  
**Fatima A. Khaja**  
**Frances A. Mummert**  
**Sonja H. Vaughan**  
**E. Lara Reduque**

**Department of  
Information Technology**

**George J. Kohut**  
**Mai-Huong Tran**  
**Neal Campion**  
**Robert Pfoutz**

**Office of  
Waste Management**

**Gilbert Osei-Kwadwo**  
**Lana Tran**

**Office of  
Comprehensive Planning**

**Kwasi Bosompem**  
**Lillian Cerdeira**  
**Donna Chamberlain**  
**Sterling Wheeler**

# DEMOGRAPHIC REPORTS<sup>©</sup>

*Providing a Summary and Analysis of Population, Housing, Development Activity  
and Land Use Data for Fairfax County*

1995



*Prepared by:*

Fairfax County  
Office of Management and Budget

Price: \$18

*For sale by:*

**Maps and Publications Sales  
12000 Government Center Parkway  
Suite 156  
Fairfax, Virginia 22035**

**(703) 324-2974  
1-(800) 828-1120 (TDD)**

**\$ 18**

# TABLE OF CONTENTS

	<u>Page</u>
Foreword .....	vi
Economic and Demographic Publications .....	vii
Fairfax County Information Network Bulletin Board .....	ix

## I. MAPS

Subcensus Tract with Supervisor Districts and Planning Districts .....	Included
Figure 1.1 – Major Roads .....	I-2
Figure 1.2 – Sewersheds .....	I-3
Table 1.1 – Fairfax County Sewershed Codes .....	I-4

## II. DEMOGRAPHIC PROFILE

Table 2.1 – Historical, Estimated and Projected Population, Housing Units and Occupied Housing Units, Fairfax County, 1970 to 2020 .....	II-2
Figure 2.1 – Historical, Estimated and Projected Population, Housing Units and Households, 1960 to 2020 .....	II-3
Table 2.2 – Historical, Estimated and Projected Population by Supervisor District, Fairfax County, 1990 to 2020 .....	II-4
Figure 2.2 – Estimated and Projected Population by Supervisor District, Fairfax County, 1995 to 2020 .....	II-5
Table 2.3 – Historical, Estimated and Projected Population by Planning District, Fairfax County, 1980 to 2020 .....	II-6
Table 2.4 – Population Age Distribution, Fairfax County, 1960 - 1990 .....	II-7
Table 2.5 – Estimated and Projected Population Age Distribution, Fairfax County, 1995 - 2010 .....	II-8
Figure 2.3 – Population Age Distribution, Fairfax County, 1980 to 2010 .....	II-9
Table 2.6 – Population of Towns in Fairfax County, 1982 to 1995 .....	II-10
Table 2.7 – Racial and Ethnic Distribution of Population, Fairfax County, 1980 and 1990 .....	II-10

	<u>Page</u>
Table 2.8 – Household and Family Income Distribution, Fairfax County, 1993 .....	II-11
Table 2.9 – Estimates of Median Household Income and Median Family Income, Fairfax County, 1979 to 1993 .....	II-11
Table 2.10 – Historical, Estimated and Projected Housing Units by Planning District, Fairfax County, 1970 to 2020 .....	II-12
Table 2.11 – Historical, Estimated and Projected Housing Units by Type of Structure, Fairfax County, 1950 to 2020 .....	II-13
Figure 2.4 – Historical and Projected Housing Units by Type of Structure .....	II-14
Table 2.12 – Rental Housing Complex Census: Total and Participating Units, Vacancy Rate and Average Monthly Rent, Fairfax County, 1975 to 1995 .....	II-15
Table 2.13 – Estimated Median Market Value, Owned Housing Units, Fairfax County, 1975 to 1995 .....	II-15
Table 2.14 – Estimated Median and Average Market Values, Owned Housing Units by Unit Type and Planning District, Fairfax County, January 1995 .....	II-16
Table 2.15 – Population, Median Household Income and Median Family Income by Jurisdiction, Washington DC Primary Metropolitan Statistical Area (PMSA), Commonwealth of Virginia and the United States .....	II-17
Figure 2.5 – Nonresidential Structure Gross Floor Area by Supervisor District and Type of Structure, January 1995 ..	II-18
Figure 2.6 – Average Annual Unemployment Rates and Total Employment, Fairfax County, 1984 to 1994 .....	II-19

## III. CURRENT POPULATION

Current Population Narrative .....	III-1
Table 3.1 – Average Household Size and Vacancy Rate by Planning District, Fairfax County, 1995 .....	III-2
Figure 3.1 – Average Household Size, Fairfax County, U.S. South Region, and the U.S., 1966 to 1995 .....	III-3
Table 3.2 – Special Institutional Population, Fairfax County, 1982 - 1995 .....	III-4

## **Table of Contents (continued)**

	<u>Page</u>
Figure 3.2 – Current Population Density, January 1995 . . . . .	III-5
Population – Supervisor District, Towns . . . . .	III-6
Population – Planning District . . . . .	III-7
Population – Sewershed . . . . .	III-8
Population – Census and Subcensus Tract . . . . .	III-11

### **IV. POPULATION FORECASTS**

Population Forecasts Narrative . . . . .	IV-1
Table 4.1 – Average Household Size by Race, Fairfax County, 1980 and 1990 . . . . .	IV-1
Table 4.2 – Current and Forecasted Average Household Size by Planning District, 1995 - 2020 . . . . .	IV-2
Figure 4.1 – Forecasted Population Growth, 1995 to 2020 . . . .	IV-3
Historical, Estimated and Forecasted Population – Supervisor District, Towns . . . . .	IV-4
Historical, Estimated and Forecasted Population – Planning District . . . . .	IV-5
Historical and Forecasted Population – Census and Subcensus Tract . . . . .	IV-6

### **V. HOUSING UNIT INVENTORY**

Housing Unit Inventory Narrative . . . . .	V-1
Table 5.1 – Total Housing Units, 1978 - 1995 . . . . .	V-1
Table 5.2 – Median Market Value of Housing Units by Supervisor District, 1994 - 1995 . . . . .	V-2
Table 5.3 – Median Market Value of Housing Units by Planning District, 1994 - 1995 . . . . .	V-2
Figure 5.1 – Housing Units by Structure Type, 1950 to 1995 . . .	V-4
Figure 5.2 – Median Market Value of Housing Units by Census Tract, January 1995 . . . . .	V-5
Housing Unit Inventory – Supervisor District, Towns . . . . .	V-6
Housing Unit Inventory – Planning District . . . . .	V-7
Housing Unit Inventory – Sewershed . . . . .	V-8
Housing Unit Inventory – Census and Subcensus Tract . . . . .	V-11
Market Value of Housing Units – Supervisor District . . . . .	V-31
Market Value of Housing Units – Planning District . . . . .	V-34

### **VI. HOUSING UNIT FORECASTS**

	<u>Page</u>
Housing Unit Forecasts Narrative . . . . .	VI-1
Table 6.1 – Housing Unit Change by Supervisor District, 1995 - 2020 . . . . .	VI-2
Table 6.2 – Housing Unit Change by Planning District, 1995 - 2020 . . . . .	VI-2
Estimated and Forecasted Housing Units – Supervisor District, Towns . . . . .	VI-3
Historical, Estimated and Forecasted Housing Units – Planning District . . . . .	VI-4
Estimated and Forecasted Housing Units – Census and Subcensus Tract . . . . .	VI-5

### **VII. RESIDENTIAL DEVELOPMENT ACTIVITY**

Residential Development Activity Narrative . . . . .	VII-1
Table 7.1 – Housing Units in the Development Process by Development Stage, 1994 - 1995 . . . . .	VII-1
Table 7.2 – Housing Units in the Development Process by Unit Type, 1994 - 1995 . . . . .	VII-2
Figure 7.1 – Housing Units in the Residential Development Process, by Structure Type, 1973 to 1995 . . . . .	VII-3
Figure 7.2 – Housing Units in the Development Process by Subcensus Tract, January 1995 . . . . .	VII-4
Summary of Residential Development Activity – Supervisor District, Towns . . . . .	VII-5
Summary of Residential Development Activity – Planning District . . . . .	VII-7
Summary of Residential Development Activity – Census and Subcensus Tract . . . . .	VII-9

### **VIII. NONRESIDENTIAL GROSS FLOOR AREA**

Nonresidential Gross Floor Area Narrative . . . . .	VIII-1
Table 8.1 – Nonresidential Structure Gross Floor Area by General Activity Type, January 1995 . . . . .	VIII-1

**Table of Contents (continued)**

	<u>Page</u>
Figure 8.1 – Existing Nonresidential Structure Gross Floor Area by Year Built and Structure Type, 1965 to 1995 . . . . .	VIII-3
Table 8.2 – Nonresidential Land Use Categories by General Activity Type . . . . .	VIII-4
Nonresidential Structure Gross Floor Area by General Activity – Inventory of Existing Structures by Year . . . . .	VIII-5
Nonresidential Structure Gross Floor Area by General Activity – Supervisor District, Towns . . . . .	VIII-6
Nonresidential Structure Gross Floor Area by General Activity – Planning District . . . . .	VIII-7
Nonresidential Structure Gross Floor Area by General Activity – Sewershed . . . . .	VIII-8
Nonresidential Structure Gross Floor Area by General Activity – Census and Subcensus Tract . . . . .	VIII-11

**IX. EXISTING LAND USE**

Existing Land Use Narrative . . . . .	IX-1
Table 9.1 – Vacant Acres in Fairfax County, 1980, 1985, 1990 and 1995 . . . . .	IX-1
Table 9.2 – Acres of Land by General Land Use Category, January 1995 . . . . .	IX-2
Figure 9.1 – Land Acreage by Major Zoning Class, Fairfax County, January 1995 . . . . .	IX-3
Table 9.3 – Total Acres by Major Zoning Class, Fairfax County, January 1995 . . . . .	IX-4
Table 9.4 – Acres of Vacant Land by Major Zoning Class, Fairfax County, January 1995 . . . . .	IX-5
Figure 9.2 – Acres of Land by Land Use, Fairfax County, January 1995 . . . . .	IX-6
Table 9.5 – Fairfax County Zoning Codes . . . . .	IX-7
Table 9.6 – Zoning Codes for Towns within Fairfax County . . . . .	IX-9
Acres of Land by Zoning Class – Supervisor District . . . . .	IX-10
Acres of Land by Zoning Class – Planning District . . . . .	IX-13
Acres of Land by Zoning Class Within the Towns in Fairfax County . . . . .	IX-19
Acres of Land by Land Use Category – Supervisor District . . . . .	IX-20
Acres of Land by Land Use Category – Planning District . . . . .	IX-24

**X. PLANNED LAND USE**

	<u>Page</u>
Planned Land Use Narrative . . . . .	X-1
Acres of Land by Planned Land Use – Supervisor District . . . . .	X-3
Acres of Land by Planned Land Use – Planning District . . . . .	X-4
Acres of Vacant and Underutilized Residential Land, Acres of Vacant Nonresidential Land, by Planned Land Use – Supervisor District . . . . .	X-5
Acres of Vacant and Underutilized Residential Land, Acres of Vacant Nonresidential Land, by Planned Land Use – Planning District . . . . .	X-6
Housing Units at Planned Buildout – Supervisor District, Towns . . . . .	X-7
Housing Units at Planned Buildout – Planning District . . . . .	X-8
Housing Units at Planned Buildout – Sewershed . . . . .	X-9
Housing Units at Planned Buildout – Census and Subcensus Tract . . . . .	X-12

## FOREWORD

The Demographic Reports is a compilation of population, housing development activity, nonresidential gross floor area, and land use information. Specifically, within the Demographic Reports are tables showing the following: a Demographic Profile of Fairfax County; population estimates, densities, and forecasts; the County's dwelling unit inventory by type of unit; ranges of estimated market values of houses in the County; housing unit forecasts; the number and type of units within the County's residential development process; nonresidential structures; and existing and planned land use data. Various geographic arrangements are used to present the data, such as Supervisor Districts, Planning Districts, Sewersheds, and Census/Subcensus Tracts. Also, within each section of the Demographic Reports is a narrative that highlights significant changes in the data, major trends/occurrences, and methodologies, where appropriate. All information, except the historical and forecast data, is as of January 1, 1995.

The Demographic Reports is the primary publication associated with the Urban Development Information System (UDIS). While the Demographic Reports summarizes and aggregates much of the information in UDIS, many additional computer generated reports exist that contain detailed information. There are reports that list each rental apartment complex with its average rents, office building listings with gross floor area information, reports on active residential development projects, and listings of wholesale and warehouse storage facilities. For a complete list of all available Economic and Demographic Publications, please refer to page vii of this section.

Additionally, the data presented in the Demographic Reports is available electronically, from the Fairfax County Information Network Bulletin Board System (FCIN BBS), and also on computer diskette from Maps and Publications Sales. Instructions on accessing the FCIN BBS are presented on page ix of the Demographic Reports.

A list of the economic and demographic information published by the Office of Management and Budget can be obtained from:

The Maps and Publications Desk  
12000 Government Center Parkway, Suite 156  
Fairfax, Virginia 22035-0009  
Telephone: (703) 324-2974

Inquiries concerning the Demographic Reports and UDIS-related information should be directed to:

The Office of Management and Budget  
12000 Government Center Parkway, Suite 561  
Fairfax, Virginia 22035-0074  
Telephone: (703) 324-4519  
TDD: 1-(800) 828-1120



# ECONOMIC & DEMOGRAPHIC PUBLICATIONS

Maps & Publication Center, Suite 156  
12000 Government Center Parkway  
Fairfax, Virginia 22035

Tel: 703/324-2974 TDD Tel: 1-800/828-1120

**Demographic Reports (1995) \$18**

*Small area housing, population, development and land use information. Estimates and projections of data presented by supervisor district, planning district, census tract and subcensus tract. Also includes data from the 1990 Census.*

**Fairfax County Profile (1991) \$9.50**

*An extensive economic and demographic profile of Fairfax County. Includes Information on income, age, race, employment and housing. Also contains information from the 1990 Census.*

**Characteristics of Fairfax County (1994) Free**

*An abbreviated demographic profile of Fairfax County.*

**Demographics by Planning Districts (1994) Free**

*The 1994 Fairfax County Biennial Household Survey results are highlighted by each Planning Districts. Information on population, housing, income, labor force, land use and other social characteristics are provided.*

**1990 Census Data by Supervisor District \$2**

*1990 Census data from Summary Tape File (STF) 1B on population, race, age, household tenure and type, housing and occupancy/vacancy rates by Supervisor District.*

**1990 Census Data by Planning District \$3**

*1990 Census data from Summary Tape File (STF) 1B on population, race, age, household tenure and type, housing and occupancy/vacancy rates by Planning District.*

**Economic & Demographic Bulletins \$1 each**

**Publication 1 - 1990 Census Update**

*1990 Census highlights from Summary Tape File (STF) 1A on population, race, age, sex and type of household.*

**Publication 2 - 1990 Census Update, Economic and Social Characteristics**

*1990 Census highlights from Summary Tape (STF) 3A on population, housing, income, employment and economic indicators.*

**Publication 3 - 1992 Household Survey Results**

*Results of the 1992 Fairfax County Biennial Household Survey. Information on population, households, education, income, employment and other social characteristics are provided.*

**Publication 4 - A Decade of Change: 1980 to 1990**

*Comparison of 1980 and 1990 decennial censuses. Provides information on changes that occurred in population, income, employment and transportation, and their future implications.*

**Publication 5 - 1994 Population Update**

*Current estimates and projections of population, households, housing units, residential vacancy rates and household sizes.*

**Publication 6 - 1994 Household Survey Results**

*Results of 1994 Fairfax County Biennial Household Survey provides information on population, households, education, income, education, labor force, day care usage, disability and other social characteristics.*

## Economic and Demographic Publications (continued)

**A Demographic Profile: Income in Fairfax County** \$3

*A geographical analysis of income and income-related demographic data from the 1990 Decennial Census, presented by census tract within the County. Includes thematic maps and discussion.*

**Rental Housing Complex Census Analysis (1995)** \$6

*Report documenting the results on the annual Rental Housing Census, providing analysis of rents and vacancy rates. Individual project data on number of units, rents and vacancy rates are provided.*

**Offices: An Inventory of Existing Structures (1995)** \$3

*A listing of office buildings in Fairfax County by type of structure. Includes gross floor area and year built information.*

**Wholesale and Warehouse Storage Facilities (1995)** \$1

*A listing of existing wholesale and warehouse storage facilities in the County. Includes data on gross floor area and year built.*

**Shopping Center Directory (1991)** \$.50

*A listing of the shopping centers in Fairfax County that includes gross floor area, map reference number, address and number of businesses.*

**Hotel/Motel Directory (1991)** \$.50

*A listing of hotels and motels within Fairfax County. Includes hotel/motel name, address, number of rooms and year built.*

**Residential Condominium Housing Projects (1995)** \$1

*A listing of residential condominium projects in Fairfax County.*

**Nonresidential Condominium Projects (1995)** \$1

*A listing of office and warehouse condominium projects including year built, gross floor areas and number of units.*

**Nonresidential Gross Floor Area (1995)** \$1

*Tables showing annual increase in gross floor area of retail, industrial, office and institutional structures.*

**Vacant Commercial/Industrial Land (1995)** \$1

*A listing of vacant parcels planned for commercial/industrial uses. Includes land area, zoning, existing land use and map reference number.*

**Vacant and Underutilized Multifamily Residential Land (1995)** \$1

*A listing of vacant or partially improved parcels for multifamily housing (12 or more housing units per acre). Includes land area, zoning, existing land use and map reference number.*

### AVAILABLE ON 3.5" DISKETTE

**Demographic Reports Data (1995)** \$10

*A series of data files on computer diskette, providing the information presented in the Demographic Reports in computer-readable format. Files are presented in Lotus 1-2-3, .wk1 format. Data topics include population, housing units, residential development activity, nonresidential structure gross floor area and land use.*

**Rental Housing Complex Census Data (1995)** \$10

*Computer-readable data collected from the annual census of rental housing projects in Fairfax County. Data fields presented include project name, number of units by type, average rent by unit type, vacant units by type and amenities included in the rent.*

# FAIRFAX COUNTY INFORMATION NETWORK BULLETIN BOARD

Data published in the Demographic Reports is now also available online to users with a PC and a modem. The files are in Lotus 1-2-3 .wk1 format.

## How to Download Demographic Reports data:

1. Set up your personal computer communications software (N/8/1).
2. Dial the FCIN BBS at (703) 802-3270 using your modem.
3. When connected, the screen will read "WELCOME TO THE FCIN BBS".
4. First time users must register. Type your name and other information items. The screen (s) will guide you. The next time you access the BBS, go directly to Step 5!
5. Once you are connected, choose the "File Listings" function from the Main Menu.
6. Select "Demographic Reports Data" to view a listing of all Demographic Reports files available. Mark the files with the space bar that you wish to download.
7. Return to the Main Menu and select "Download". Affirm that you want to download flagged files, select the appropriate communications protocol, and proceed with the file transfer.
8. To exit type G to log-off the system.

Additional information on downloading is available on the BBS under the Item *Download File(s)*, by typing "H" or by calling the Fairfax County Bulletin Board Voice Help Line at (703) 324-4584.

# I. MAPS

The information contained in the Demographic Reports is presented in a variety of geographic arrangements – supervisor district, planning district, sanitary sewershed, census tract and subcensus tract. The large scale map (4,000 feet = 1 inch) included with the Demographic Reports displays supervisor districts, planning districts and census and subcensus tracts. Smaller scale maps of major roads and sanitary sewersheds are displayed on the following pages. Additional copies of the large scale map are available through Maps and Publications Sales in the Fairfax County Government Center (see address on page ii).

# Major Roads

Fairfax County, Virginia

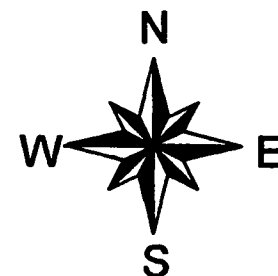
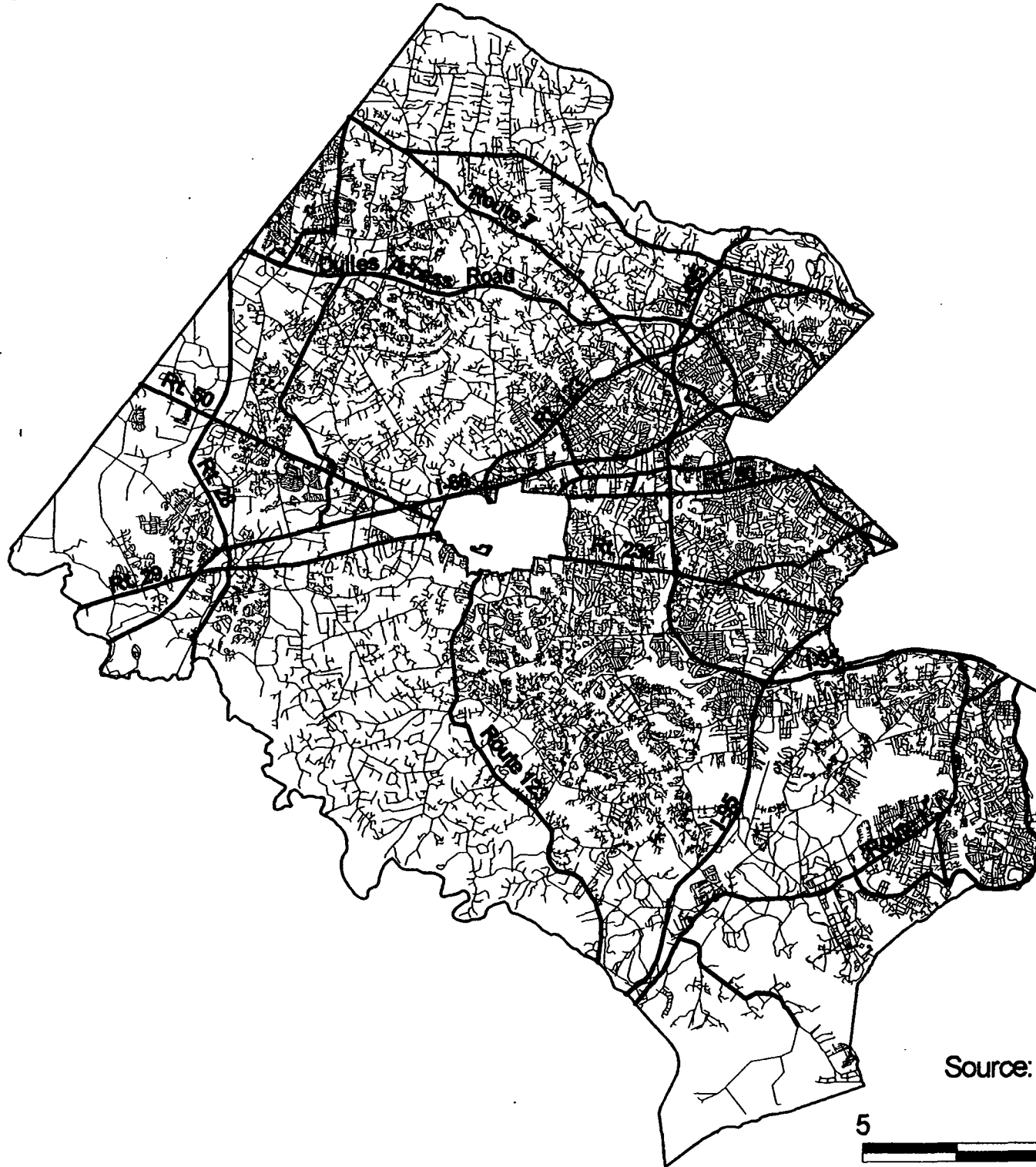

Source: U.S. Bureau of the Census, TIGER 1994.



# Sewersheds

## Fairfax County, Virginia

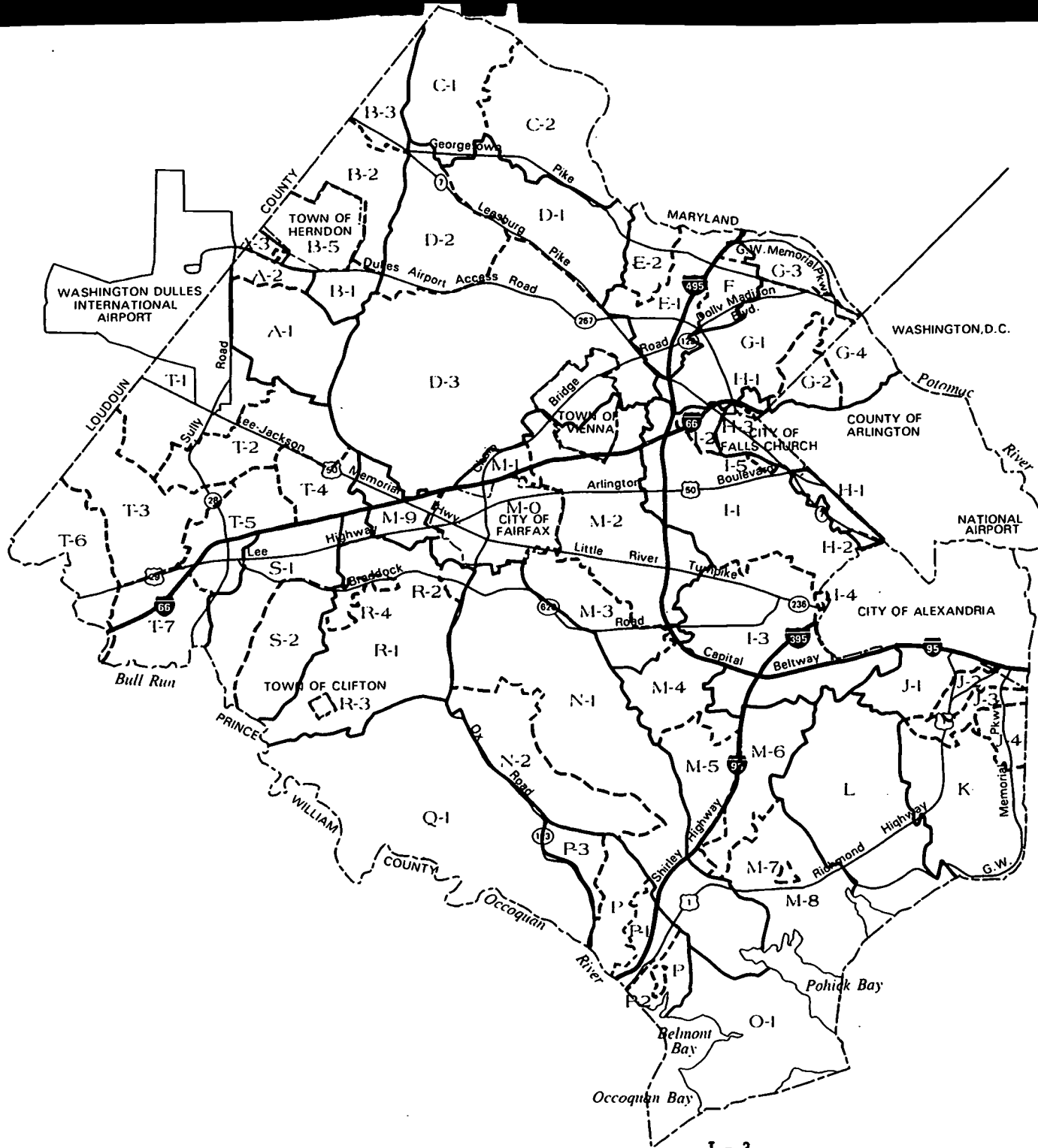

TABLE 1.1

**Fairfax County Sewershed Codes**

<u>Code</u>	<u>Sewershed</u>	<u>Servicing Treatment Plant</u>	<u>Code</u>	<u>Sewershed</u>	<u>Servicing Treatment Plant</u>
A-1	Horsepen Creek	Blue Plains	M-7	Accotink Village	Lower Potomac
A-2	Horsepen Creek E Branch	Blue Plains	M-8	Fort Belvoir	Lower Potomac
A-3	Horsepen Creek F Branch	Blue Plains	M-9	Accotink Creek	Lower Potomac
B-1	Sugarland Run	Blue Plains	N-1	Pohick Creek	Lower Potomac
B-2	Sugarland Run	Blue Plains	N-2	Pohick Creek	Lower Potomac
B-3	Sugarland Run	Blue Plains	O-1	Kane Branch	None
B-5	Sugarland Run (Herndon) and Follylick Branch	Blue Plains	P	Mill Branch	None
C-1	Nichols Run	None	P-1	Mill Branch (Lorton South)	Lower Potomac
C-2	Pond Branch	Blue Plains	P-2	Mill Branch (Harbor View)	Harbor View
D-1	Difficult Run	Blue Plains	P-3	Mill Branch (Giles Run)	Lower Potomac
D-2	Colvin Run	Blue Plains	Q-1	Occoquan	None
D-3	Difficult Run	Blue Plains	R-1	Popes Head Creek	None
E-1	Scotts Run	Blue Plains	R-2	Upper Popes Head Creek	Lower Potomac
E-2	Bull Neck Run	None	R-3	Popes Head Creek (Clifton)	Pump and Haul
F	Dead Run	Blue Plains	R-4	Popes Head Creek	UOSA
G-1	Pimmit	Blue Plains	S-1	Little Rocky Run	UOSA
G-2	Little Pimmit	Blue Plains	S-2	Johnny Moore Creek	None
G-3	Turkey Run	Blue Plains	T-1	Cub Run	UOSA
G-4	Strohman Run	Blue Plains	T-2	Cub Run	UOSA
H-1	Four Mile Run	Arlington	T-3	Cub Run	UOSA
H-2	Four Mile Run	Arlington	T-4	Cub Run	UOSA
H-3	Cameron (Falls Church Service Area)	Alexandria and Arlington	T-5	Cub Run	UOSA
I-1	Cameron Run	Alexandria	T-6	Bull Run	None
I-2	Cameron Run	Alexandria	T-7	Cub Run	UOSA
I-3	Cameron Run	Alexandria			
I-4	Cameron Run	Alexandria			
I-5	Cameron Run	Alexandria			
J-1	Cameron Run	Alexandria			
J-2	Cameron Run	Alexandria			
J-3	Cameron Run	Alexandria			
J-4	Cameron Run	Alexandria			
K	Little Hunting Creek	Lower Potomac			
L	Dogue Creek	Lower Potomac			
M-0	Accotink Creek (City of Fairfax)	Lower Potomac			
M-1	Accotink Creek	Lower Potomac			
M-2	Accotink Creek	Lower Potomac			
M-3	Accotink Creek	Lower Potomac			
M-4	Accotink Creek	Lower Potomac			
M-5	Accotink Creek	Lower Potomac			
M-6	Long Branch	Lower Potomac			



## II. DEMOGRAPHIC PROFILE

## DEMOGRAPHIC PROFILE

The following section provides an overview of the information that is provided by the Fairfax County Office of Management and Budget in the 1995 Demographic Reports. This section presents tables and graphics on the following subjects:

Population, Housing Units and Households  
Population Age Distributions  
Racial and Ethnic Distributions  
Measures of Income  
Rental Housing Complex Characteristics  
Market Value of Housing Units  
Nonresidential Structure Gross Floor Area  
Unemployment Rates and Total Employment

Data is presented covering historical, current and future time frames.

For more detailed information about a particular subject, please refer to the individual sections of the Demographic Reports.

TABLE 2.1

**Historical, Estimated and Projected Population, Housing Units and Occupied Housing Units  
Fairfax County, 1970 to 2020**

Year	Population			Total Housing Units <sup>a</sup>	Occupied Housing Units <sup>b</sup> (Households)		
	Total	Average Annual Increase	Average Annual Growth Rate		Total	Average Annual Increase	Average Annual Growth Rate
1970	454,275 <sup>c</sup>	--	--	130,800	126,500	--	--
1975	537,200	16,600	3.4%	173,000	166,400	8,000	5.6%
1980	596,901	11,940	2.1%	215,600	205,200	7,800	4.3%
1985	668,300	14,300	2.3%	247,800	238,500	6,700	3.1%
1990	818,584	30,057	4.1%	302,500	292,300	10,800	4.2%
1991	827,100	8,500	1.0%	308,200	296,300	4,000	1.4%
1992	837,100	10,000	1.2%	312,200	301,900	5,600	1.9%
1993	851,900	14,800	1.8%	316,700	307,000	5,100	1.7%
1994	863,100	11,200	1.3%	322,000	312,000	5,000	1.6%
1995	879,400	16,300	1.9%	328,200	317,000	5,000	1.6%
2000	943,300	12,800	1.4%	352,700	340,500	4,700	1.4%
2005	1,000,500	11,400	1.2%	375,700	362,600	4,400	1.3%
2010	1,058,300	11,600	1.1%	400,300	386,300	4,700	1.3%
2015	1,120,900	12,500	1.2%	427,000	412,000	5,100	1.3%
2020	1,193,400	14,500	1.3%	458,200	442,000	6,000	1.4%

Sources: U.S. Bureau of the Census, 1970, 1980 and 1990 (figures as of April 1);  
Fairfax County Office of Management and Budget, 1991 through 2020 (figures as of January 1).

<sup>a</sup> 1970 and 1980 figures are Census counts and include Fort Belvoir.

<sup>b</sup> 1970, 1980 and 1990 figures are Census counts and include Fort Belvoir.

<sup>c</sup> Datum is 1970 Census total population figure after 1975 revision.

Figure 2.1

# Historical, Estimated and Projected Population, Housing Units and Households 1960 to 2020

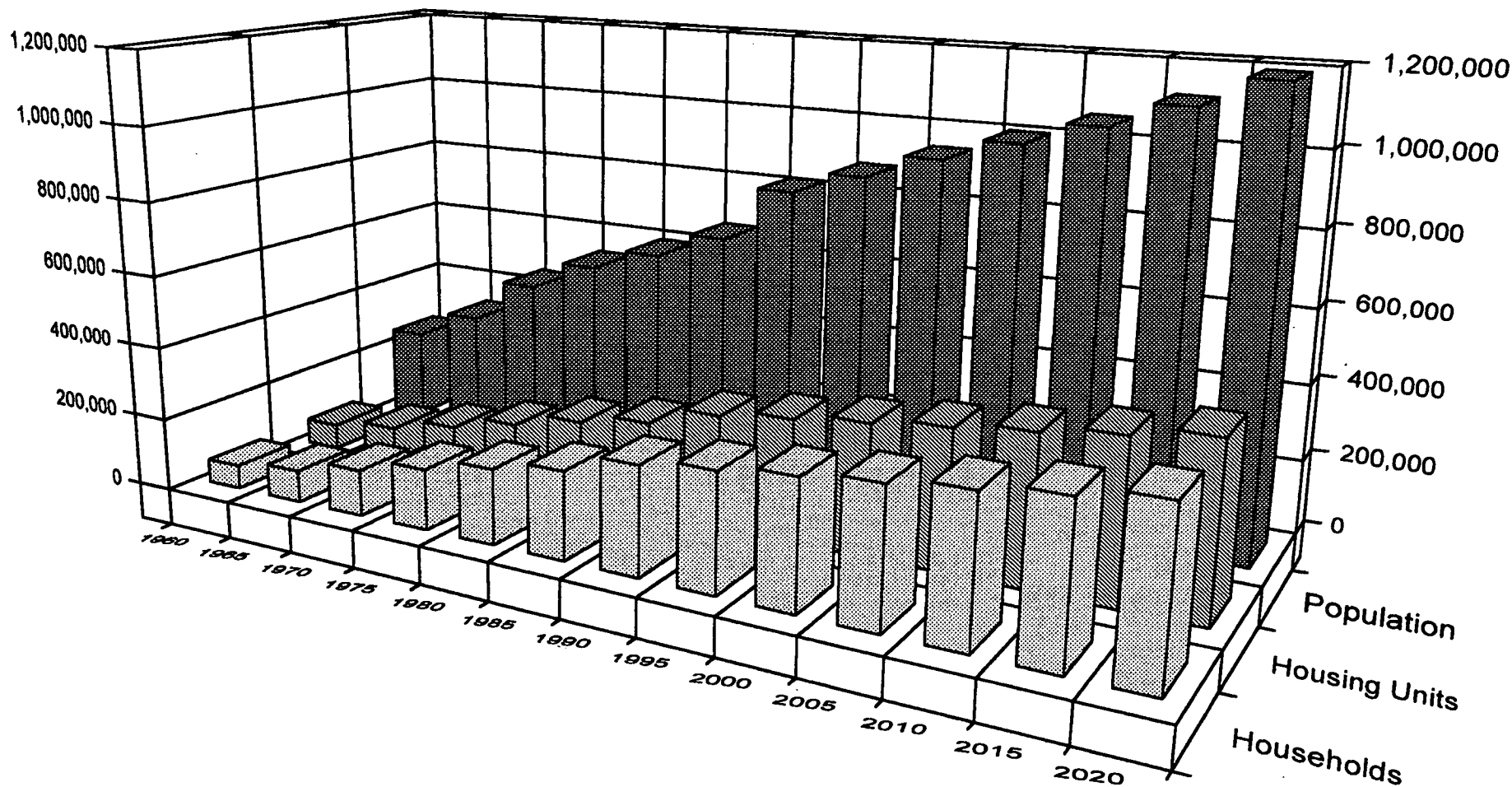

Sources: U.S. Bureau of the Census, U.S. Census of Population and Housing: 1960, 1970, 1980 and 1990;  
Fairfax County Office of Management and Budget.

TABLE 2.2

**Historical, Estimated and Projected Population by Supervisor District**  
**Fairfax County, 1990 to 2020**

<b>Supervisor District</b>	<b>1990</b>	<b>1995</b>	<b>2000</b>	<b>2005</b>	<b>2010</b>	<b>2015</b>	<b>2020</b>
Braddock	90,767	89,824	90,215	93,549	96,385	99,344	102,675
Dranesville <sup>a</sup>	92,296	97,924	105,070	110,138	114,614	119,473	125,109
Hunter Mill <sup>b</sup>	90,714	97,934	108,995	117,014	125,732	135,346	146,868
Lee	90,049	93,513	108,608	119,314	130,412	142,109	154,515
Mason	90,725	89,855	91,693	95,066	98,742	102,785	107,586
Mount Vernon	87,124	96,114	100,549	104,642	108,654	112,966	118,001
Providence	90,778	95,314	100,446	107,026	114,397	122,590	132,460
Springfield <sup>c</sup>	92,626	98,607	103,156	107,148	110,623	114,253	118,339
Sully	93,505	120,316	134,599	146,564	158,694	172,005	187,877
<b>Fairfax County</b>	<b>818,584</b>	<b>879,401</b>	<b>943,333</b>	<b>1,000,461</b>	<b>1,058,252</b>	<b>1,120,870</b>	<b>1,193,430</b>

Sources: U.S. Bureau of the Census, U.S. Census of Population and Housing: 1990. (Figures as of April 1.)  
Fairfax County Office of Management and Budget: 1995 through 2020. (Figures as of January 1.)

Note: Figures may not sum to total due to rounding.

<sup>a</sup> Includes the Town of Herndon.

<sup>b</sup> Includes the Town of Vienna.

<sup>c</sup> Includes the Town of Clifton.

Figure 2.2

# Estimated and Projected Population by Supervisor District Fairfax County, 1995 to 2020

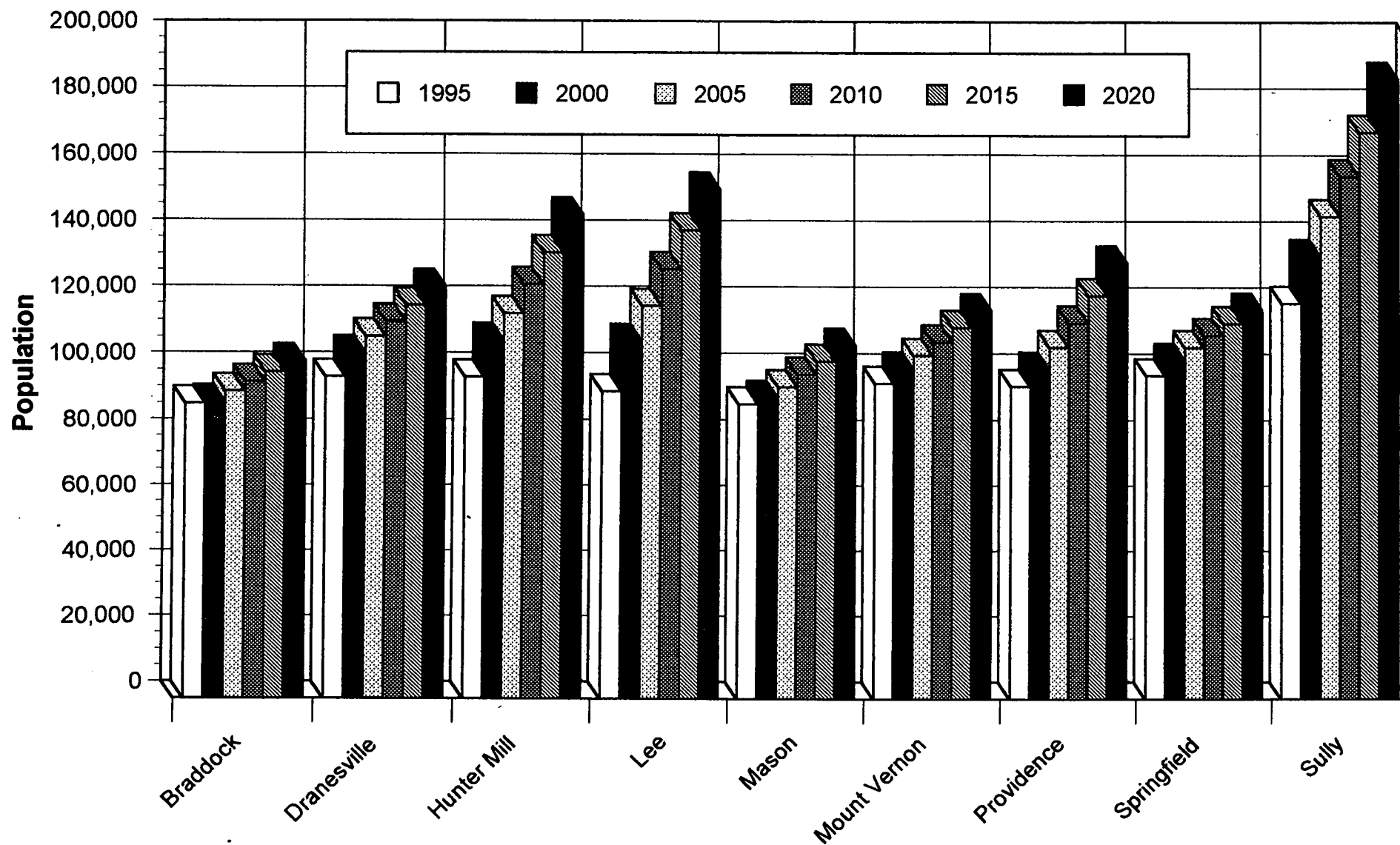

Source: Fairfax County Office of Management and Budget.

TABLE 2.3

**Historical, Estimated and Projected Population by Planning District  
Fairfax County, 1980 to 2020**

Planning District	1980	1990	1995	2000	2005	2010	2015	2020
Annandale	66,466	66,329	67,635	68,068	69,418	70,701	72,068	73,626
Baileys	30,290	38,392	37,499	38,160	40,198	42,604	45,318	48,611
Bull Run	23,566	66,234	87,641	98,506	108,665	119,232	130,850	144,766
Fairfax	32,332	45,244	50,524	53,714	56,860	59,823	63,085	66,959
Jefferson	38,152	42,859	45,167	45,562	47,160	48,980	51,017	53,478
Lincolnia	9,978	14,010	13,388	14,147	15,001	15,934	16,931	18,094
Lower Potomac	16,305	24,371	25,830	28,210	29,995	32,135	34,496	37,356
McLean	54,669	58,747	62,566	66,446	68,862	71,154	73,683	76,667
Mount Vernon	79,533	82,483	85,539	87,206	91,900	96,284	101,069	106,718
Pohick <sup>a</sup>	71,543	127,040	132,049	137,459	143,353	148,553	153,939	159,970
Rose Hill	23,262	34,520	38,692	42,646	46,174	50,185	54,583	59,860
Springfield	31,667	39,919	43,240	54,018	58,620	63,058	67,382	70,892
Upper Potomac <sup>b</sup>	70,795	125,169	138,227	154,662	166,813	179,359	193,158	209,582
Vienna <sup>c</sup>	48,343	53,267	51,402	54,531	57,441	60,252	63,292	66,851
<b>Fairfax County</b>	<b>596,901</b>	<b>818,584</b>	<b>879,401</b>	<b>943,333</b>	<b>1,000,461</b>	<b>1,058,252</b>	<b>1,120,870</b>	<b>1,193,430</b>

Sources: U.S. Bureau of the Census, U.S. Census of Population and Housing: 1980 and 1990 (Figures as of April 1).  
Fairfax County Office of Management and Budget: 1995 through 2020 (Figures as of January 1).

Note: Figures may not sum to total due to rounding.

<sup>a</sup> Includes the Town of Clifton.

<sup>b</sup> Includes the Town of Herndon.

<sup>c</sup> Includes the Town of Vienna.

TABLE 2.4

**Population Age Distribution  
Fairfax County, 1960 - 1990**

Age Group	1960		1970		1980		1990	
	Persons	Percent	Persons	Percent	Persons	Percent	Persons	Percent
Under 5	34,475	13.9%	40,726	9.0%	38,326	6.4%	57,892	7.1%
5 to 9	33,902	13.6%	52,113	11.5%	45,307	7.6%	55,698	6.8%
10 to 14	27,034	10.9%	56,178	12.3%	54,936	9.2%	53,112	6.5%
15 to 19	15,881	6.4%	42,934	9.4%	54,754	9.2%	54,207	6.6%
20 to 24	13,136	5.3%	34,269	7.5%	47,646	8.0%	59,425	7.3%
25 to 34	36,708	14.7%	64,926	14.3%	112,191	18.8%	158,602	19.4%
35 to 44	47,981	19.3%	67,648	14.9%	98,037	16.4%	158,119	19.3%
45 to 54	22,834	9.2%	59,141	13.0%	70,151	11.8%	107,709	13.2%
55 to 64	9,686	3.9%	23,412	5.1%	48,564	8.1%	60,276	7.4%
65 and Over	7,260	2.9%	13,674	3.0%	26,989	4.5%	53,544	6.5%
<b>Total</b>	<b>248,897</b>	<b>100.0%</b>	<b>455,021</b>	<b>100.0%</b>	<b>596,901</b>	<b>100.0%</b>	<b>818,584</b>	<b>100.0%</b>
<b>Median Age</b>	<b>25.0 Years</b>		<b>25.2 Years</b>		<b>30.1 Years</b>		<b>33.1 Years</b>	

Source: U.S. Bureau of the Census, U.S. Census of Population.

Notes: Percentages may not sum to total due to rounding.

The 1970 Fairfax County population total was revised to 454,275 in September 1975 by the Census Bureau. However, population age distributions were not made available based on this revised total.



TABLE 2.5

**Estimated and Projected Population Age Distribution  
Fairfax County, 1995 to 2010**

Age Group	1995		2000		2005		2010	
	Persons	Percent	Persons	Percent	Persons	Percent	Persons	Percent
Under 5	55,835	6.3%	53,869	5.7%	51,714	5.2%	54,466	5.1%
5 to 9	61,297	7.0	60,109	6.4	58,857	5.9	57,274	5.4
10 to 14	57,150	6.5	65,025	6.9	64,114	6.4	63,362	6.0
15 to 19	58,853	6.7	60,579	6.4	71,174	7.1	70,712	6.7
20 to 24	52,695	6.0	60,468	6.4	62,273	6.2	72,978	6.9
25 to 34	143,335	16.3	126,942	13.5	127,337	12.7	134,858	12.7
35 to 44	166,819	19.0	168,717	17.9	155,778	15.6	138,548	13.1
45 to 54	148,648	16.9	169,849	18.0	167,584	16.8	168,352	15.9
55 to 64	71,044	8.1	99,037	10.5	141,696	14.2	162,967	15.4
65 and Over	63,725	7.2	78,738	8.3	99,934	10.0	134,733	12.7
<b>Total</b>	<b>879,401</b>	<b>100.0%</b>	<b>943,333</b>	<b>100.0%</b>	<b>1,000,461</b>	<b>100.0%</b>	<b>1,058,252</b>	<b>100.0%</b>

Source: Fairfax County Office of Management and Budget.

Notes: Figures may not sum to total due to rounding.

Includes the populations of Fort Belvoir and the D.C. Correctional Complex at Lorton.

Figure 2.3

# Population Age Distribution Fairfax County, 1980 - 2010

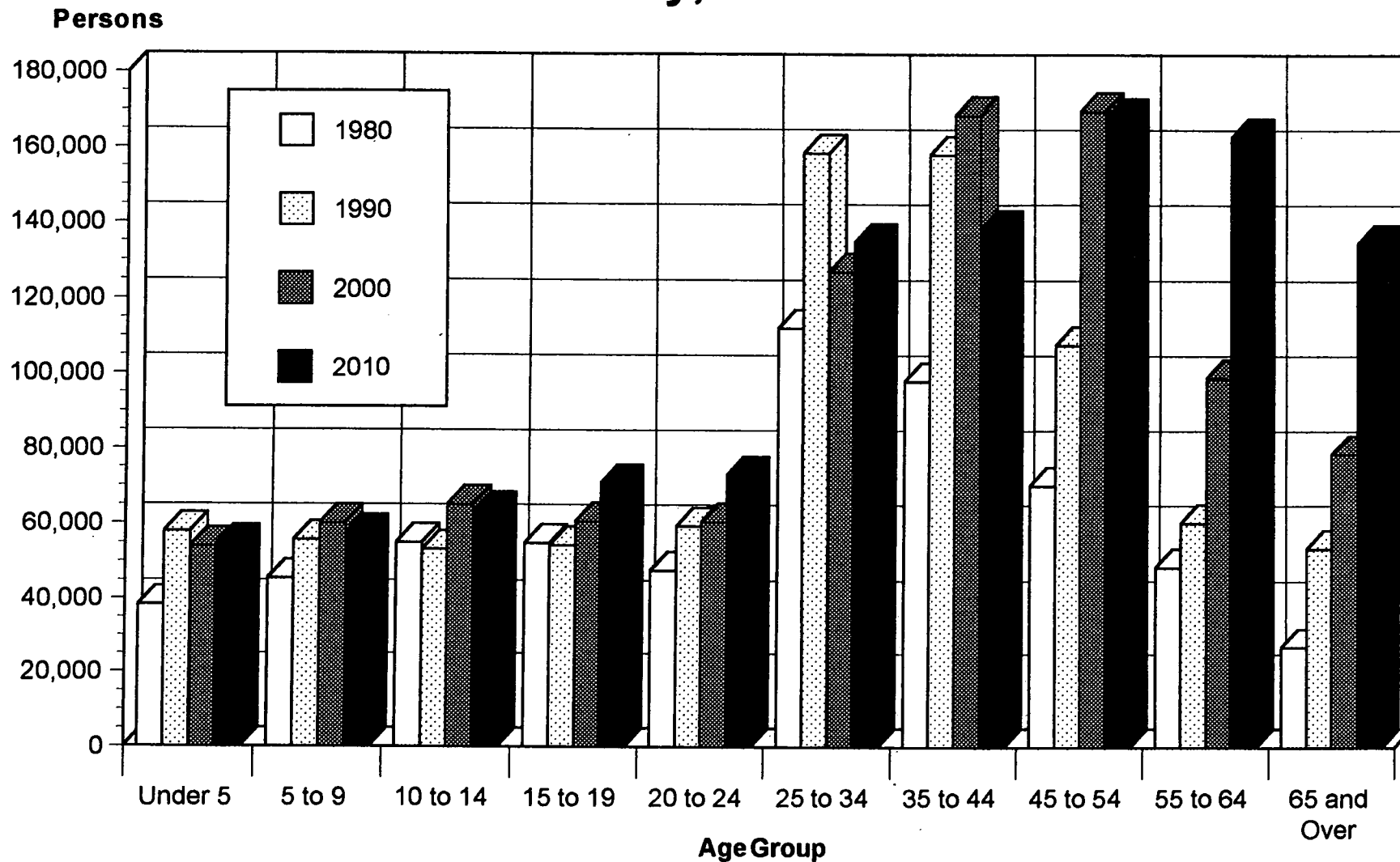

Sources: U.S. Bureau of the Census, U.S. Census of Population and Housing: 1980, 1990;  
Fairfax County Office of Management and Budget: 2000, 2010.

TABLE 2.6

**Population of Towns in Fairfax County  
1982 to 1995**

Year	Town of Clifton	Town of Herndon	Town of Vienna	Total
1982	229	12,524	14,999	27,752
1983	225	12,530	14,942	27,697
1984	240	13,011	15,717	28,968
1985	241	13,040	15,582	28,863
1986	226	13,318	13,829	27,373
1987	210	14,391	13,642	28,243
1988	215	15,150	14,429	29,794
1989	216	16,127	14,674	31,017
1990	176	16,143	14,852	31,171
1991	196	16,521	14,704	31,421
1992	224	15,750	14,911	30,885
1993	226	15,792	15,128	31,146
1994	222	16,061	14,644	30,927
1995	222	16,737	14,838	31,798

Sources: U.S. Bureau of the Census, U.S. Census of Population and Housing: 1990.

Fairfax County Office of Management and Budget, 1982-1989 and 1991-1995.

TABLE 2.7

**Racial and Ethnic Distribution of Population  
Fairfax County, 1980 and 1990**

Race	1980		1990	
	Persons	Percent	Persons	Percent
White	532,204	89.2%	665,399	81.3%
Black	35,050	5.9%	63,325	7.7%
Asian and Pacific Islander	23,184	3.9%	69,338	8.5%
American Indian, Eskimo and Aleut	1,380	0.2%	2,038	0.2%
Other	5,083	0.9%	18,484	2.3%
<b>Total</b>	<b>596,901</b>	<b>100.0%</b>	<b>818,584</b>	<b>100.0%</b>
Hispanic <sup>a</sup>	19,983	3.3%	51,874	6.3%

Source: U.S. Bureau of the Census, U.S. Census of Population and Housing, 1980 and 1990.

Note: Percentages may not sum to total due to rounding.

<sup>a</sup> Hispanic persons may be of any race.

TABLE 2.8

**Household and Family Income Distribution**  
**Fairfax County, 1993**

Income Level	Percent of Households	Percent of Families
Under \$25,000	12.0%	8.9%
\$25,000 - \$49,999	21.4%	16.1%
\$50,000 - \$74,999	27.0%	27.3%
\$75,000 - \$99,999	16.7%	19.7%
\$100,000 - \$149,999	16.9%	20.9%
\$150,000 or More	6.0%	7.1%
<b>Total</b>	<b>100.0%</b>	<b>100.0%</b>

Source: 1994 Household Survey, Fairfax County Office of Management and Budget.

Notes: Percentages may not sum to total due to rounding;  
 Data pertain to income reported for 1993.

TABLE 2.9

**Estimates of Median Household Income**  
**and Median Family Income**  
**Fairfax County, 1979 to 1993**

Year	Median Household Income	Median Family Income
1979	\$30,100	\$33,200
1981	n/a	\$41,600
1983	\$42,600	\$47,100
1985	\$49,700	\$54,200
1987	\$55,100	\$62,000
1989	\$59,300	\$65,200
1991	\$61,000	\$70,000
1993	\$64,000	\$72,000

Sources: U.S. Bureau of the Census, U.S. Census of Population and Housing; 1980 and 1990; Summary Tape File 3, Virginia.

Fairfax County Office of Management and Budget.

Note: Figures are rounded to the nearest \$100.

TABLE 2.10

**Historical, Estimated and Projected Housing Units by Planning District  
Fairfax County, 1970 to 2020**

Planning District	1970	1980	1990	1995	2000	2005	2010	2015	2020
Annandale	17,413	23,600	24,901	25,157	25,304	25,852	26,392	26,969	27,632
Baileys	10,770	13,963	16,573	16,931	17,259	18,246	19,423	20,752	22,367
Bull Run	3,927	7,705	24,559	33,117	37,434	41,329	45,720	50,562	56,388
Fairfax	6,783	11,838	17,181	18,854	20,178	21,437	22,791	24,289	26,082
Jefferson	12,587	15,033	17,365	18,362	18,504	19,223	20,056	20,992	22,126
Lincolnia	3,592	4,128	5,464	5,571	5,862	6,256	6,693	7,160	7,703
Lower Potomac <sup>a</sup>	3,350	3,968	3,936	4,997	5,949	6,664	7,522	8,471	9,620
McLean	13,307	19,874	23,601	24,068	25,563	26,686	27,845	29,139	30,689
Mount Vernon	23,565	31,491	35,338	36,009	36,627	38,476	40,472	42,661	45,259
Pohick <sup>b</sup>	3,884	22,547	41,032	43,736	45,367	47,403	49,269	51,203	53,380
Rose Hill	5,979	7,591	13,524	16,267	17,994	19,579	21,410	23,420	25,835
Springfield	8,914	11,432	14,590	15,239	19,319	21,204	23,035	24,807	26,199
Upper Potomac <sup>c</sup>	6,239	25,702	44,898	49,909	56,174	60,906	65,974	71,574	78,281
Vienna <sup>d</sup>	10,507	16,774	19,502	19,934	21,146	22,396	23,660	25,033	26,652
<b>Fairfax County</b>	<b>130,817</b>	<b>215,646</b>	<b>302,464</b>	<b>328,151</b>	<b>352,680</b>	<b>375,656</b>	<b>400,262</b>	<b>427,033</b>	<b>458,214</b>

Sources: U.S. Bureau of the Census: 1970 and 1980.  
Fairfax County Office of Management and Budget: 1990 through 2020.

Note: Figures may not sum to total due to rounding.

<sup>a</sup> 1970 and 1980 figures include units at Fort Belvoir; 1990 through 2020 do not. As of April 1990, there were 2,106 units on Fort Belvoir.

<sup>b</sup> Includes the Town of Clifton.

<sup>c</sup> Includes the Town of Herndon.

<sup>d</sup> Includes the Town of Vienna.

TABLE 2.11

**Historical, Estimated and Projected Housing Units  
By Type of Structure  
Fairfax County, 1950 to 2020**

Year	Single Family		Townhouse		Multifamily		Total	
	Housing Units	Percent of Total	Housing Units	Percent of Total	Housing Units	Percent of Total	Housing Units	Percent of Total
1950	19,979	75.2 %	1,997	7.5 %	4,582	17.3 %	26,558	100.0 %
1960	59,261	85.7	3,526	5.1	6,394	9.2	69,181	100.0
1970	91,134	69.7	7,747	5.9	31,887	24.4	130,768	100.0
1980	125,717	58.3	31,882	14.8	58,072	26.9	215,671	100.0
1990	165,404	53.7	66,828	21.7	75,734	24.6	307,966	100.0
1995	172,359	52.5	77,356	23.6	78,436	23.9	328,151	100.0
2000	182,262	51.7	87,212	24.7	83,206	23.6	352,680	100.0
2010	189,662	47.4	114,615	28.6	95,985	24.0	400,262	100.0
2020	195,040	42.6	150,508	32.8	112,666	24.6	458,214	100.0

Sources: U.S. Bureau of the Census, U.S. Census of Population and Housing: 1950 through 1990;  
Fairfax County Office of Management and Budget: 1995 through 2020.

Notes: 1995 figures are estimates; 2000 through 2020 figures are forecasts.

The single family category includes single family and mobile home units. The townhouse category includes townhouses, duplex units and multiplex units. Multifamily includes garden apartments, mid rise apartments and high rise apartments.

# Historical and Projected Housing Units By Type of Structure 1950 to 2020

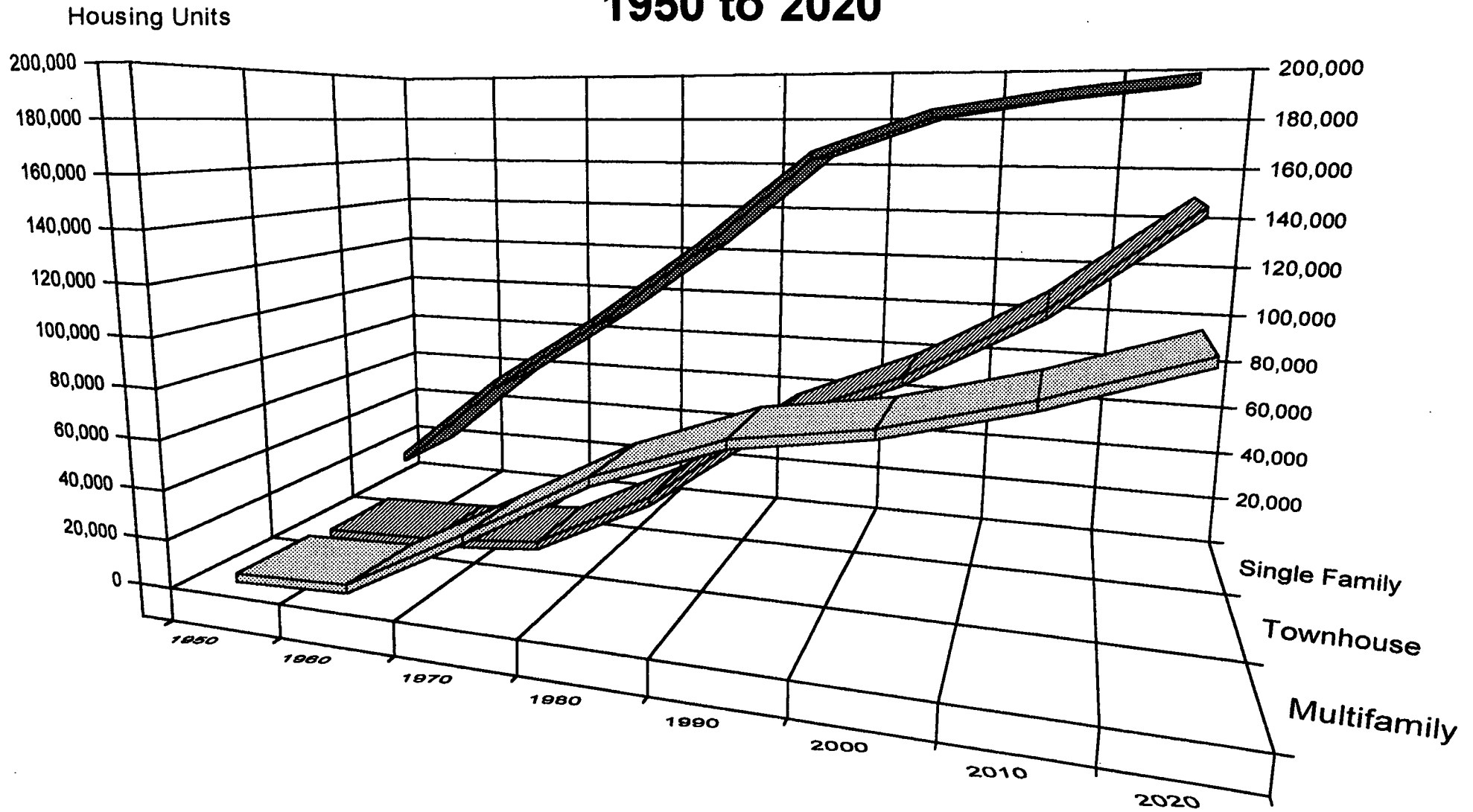

Sources: U.S. Bureau of the Census, U.S. Census of Population and Housing: 1950 through 1990;  
Fairfax County Office of Management and Budget: 2000 through 2020.

TABLE 2.12

**Rental Housing Complex Census:  
Total and Participating Units,  
Vacancy Rate and Average Monthly Rent  
Fairfax County, 1975 to 1995**

Year	Total Units	Participating Units	Vacancy Rate	Average Monthly Rent
1975	43,190	43,005	4.4 %	\$ 236
1980	44,130	43,813	4.1 %	\$ 334
1981	43,114	42,653	2.6 %	\$ 367
1982	42,238	41,641	2.6 %	\$ 403
1983	41,600	40,918	3.0 %	\$ 430
1984	40,813	39,676	2.1 %	\$ 466
1985	40,186	38,950	2.2 %	\$ 517
1986	40,762	39,236	2.5 %	\$ 566
1987	41,745	40,003	4.4 %	\$ 615
1988	42,802	40,522	3.1 %	\$ 662
1989	45,578	45,474	7.4 %	\$ 705
1990	48,567	48,406	6.6 %	\$ 734
1991	49,253	49,097	7.6 %	\$ 747
1992	50,148	50,071	6.2 %	\$ 739
1993	49,811	49,754	5.2 %	\$ 753
1994	50,184	50,184	4.7 %	\$ 767
1995	50,243	49,677	4.9 %	\$ 792

Source: *Rental Housing Complex Census Analysis, August 1995, Fairfax County Office of Management and Budget.*

Note: Vacancy rate and average monthly rent figures are calculated based on information provided by those rental housing complexes participating in the census of units located in major rental housing projects having five or more units.

TABLE 2.13

**Estimated Median Market Value  
Owned Housing Units  
Fairfax County, 1975 to 1995**

Year	Median Market Value	Percent Change
1975	\$ 59,100	-
1976	62,600	5.9
1977	64,600	3.2
1978	68,200	5.6
1979	75,200	10.3
1980	87,200	16.0
1981	97,700	12.0
1982	104,100	6.6
1983	103,600	-0.5
1984	108,100	4.3
1985	110,500	2.2
1986	118,400	7.1
1987	133,400	12.7
1988	152,800	14.5
1989	179,500	17.5
1990	194,700	8.5
1991	190,100	-2.4
1992	183,700	-3.4
1993	183,500	-0.1
1994	184,400	0.5
1995	186,800	1.3

Source: Fairfax County Office of Management and Budget.



TABLE 2.14

**Estimated Median and Average Market Values  
Owned Housing Units by Unit Type and Planning District  
Fairfax County, January 1995**

Planning District	Median Market Value				Average Market Value			
	Single Family	Townhouse	Condominium Apartment	All Units	Single Family	Townhouse	Condominium Apartment	All Units
Annandale	\$205,638	\$161,126	\$72,500	\$188,338	\$220,036	\$159,629	\$80,580	\$196,740
Baileys	\$226,923	\$167,225	\$79,564	\$146,391	\$258,691	\$177,960	\$87,383	\$170,122
Bull Run	\$222,015	\$132,777	\$101,100	\$167,222	\$231,417	\$134,443	\$103,660	\$182,773
Fairfax	\$261,297	\$157,183	\$97,911	\$206,253	\$283,975	\$163,285	\$98,001	\$228,451
Jefferson	\$179,525	\$160,389	\$80,467	\$165,036	\$198,048	\$166,835	\$86,284	\$170,152
Lincolnia	\$183,486	\$173,022	\$77,677	\$172,185	\$201,366	\$184,088	\$78,298	\$184,433
Lower Potomac	\$166,123	\$118,193		\$125,758	\$214,958	\$114,628		\$152,743
McLean	\$318,000	\$244,275	\$123,827	\$279,511	\$378,305	\$264,759	\$126,307	\$335,868
Mount Vernon	\$223,595	\$109,700	\$86,335	\$166,680	\$243,756	\$114,558	\$93,701	\$189,563
Pohick <sup>a</sup>	\$229,578	\$139,475	\$99,086	\$197,952	\$258,152	\$141,362	\$98,670	\$216,249
Rose Hill	\$182,777	\$172,361	\$119,088	\$171,538	\$194,797	\$173,859	\$115,655	\$178,831
Springfield	\$181,193	\$142,777	\$72,350	\$165,760	\$192,734	\$150,364	\$71,799	\$169,104
Upper Potomac <sup>b</sup>	\$245,997	\$137,166	\$78,400	\$198,400	\$284,386	\$145,794	\$82,329	\$225,652
Vienna <sup>c</sup>	\$237,500	\$172,247	\$80,549	\$220,711	\$258,224	\$187,318	\$79,018	\$237,428
Fairfax County	\$226,601	\$143,366	\$86,335	\$186,813	\$258,190	\$150,724	\$93,379	\$211,702

Note: The townhouse category includes townhouses, duplex units and multiplex units. Condominium apartments include new and converted condominium multifamily units.

<sup>a</sup> Includes the Town of Clifton.

<sup>b</sup> Includes the Town of Herndon.

<sup>c</sup> Includes the Town of Vienna.

TABLE 2.15

**Population, Median Household Income and Median Family Income by Jurisdiction**  
**Washington DC Primary Metropolitan Statistical Area (PMSA), Commonwealth of Virginia and the United States**

Jurisdiction	1990 Population	1989 Median Household Income	1989 Median Family Income
Fairfax County, VA	818,584	\$ 59,284	\$ 65,201
Arlington County, VA	170,936	\$ 44,600	\$ 55,346
Clarke County, VA	12,101	\$ 34,636	\$ 38,096
Culpeper County, VA	27,791	\$ 33,523	\$ 36,605
Fauquier County, VA	48,741	\$ 45,222	\$ 48,806
King George County, VA	13,527	\$ 35,556	\$ 38,210
Loudoun County, VA	86,129	\$ 52,064	\$ 56,006
Prince William County, VA	215,686	\$ 49,370	\$ 52,078
Spotsylvania County, VA	57,403	\$ 41,342	\$ 43,596
Stafford County, VA	61,236	\$ 44,661	\$ 47,526
Warren County, VA	26,142	\$ 31,062	\$ 35,130
Alexandria City, VA	111,183	\$ 41,472	\$ 50,812
Fairfax City, VA	19,622	\$ 50,913	\$ 56,419
Falls Church City, VA	9,578	\$ 51,011	\$ 62,187
Fredericksburg City, VA	19,027	\$ 26,614	\$ 33,353
Manassas City, VA	27,957	\$ 46,674	\$ 51,045
Manassas Park City, VA	6,734	\$ 39,076	\$ 40,213
Calvert County, MD	51,372	\$ 47,608	\$ 50,845
Charles County, MD	101,154	\$ 46,415	\$ 49,724
Frederick County, MD	150,208	\$ 41,382	\$ 45,847
Montgomery County, MD	757,027	\$ 54,089	\$ 61,988
Prince Georges County, MD	729,268	\$ 43,127	\$ 48,471
District of Columbia	606,900	\$ 30,727	\$ 36,256
Berkeley County, WV	59,253	\$ 27,412	\$ 32,040
Jefferson County, WV	35,926	\$ 30,941	\$ 34,887
Washington DC-MD-VA-WV PMSA	4,223,485	\$ 45,901	\$ 52,669
Commonwealth of Virginia	6,187,358	\$ 33,328	\$ 38,213
United States of America	249,632,692	\$ 30,056	\$ 35,225

Source: U.S. Bureau of the Census, U.S. Census of Population and Housing: 1990.

Figure 2.5

# Nonresidential Structure Gross Floor Area By Supervisor District and Type of Structure January 1995

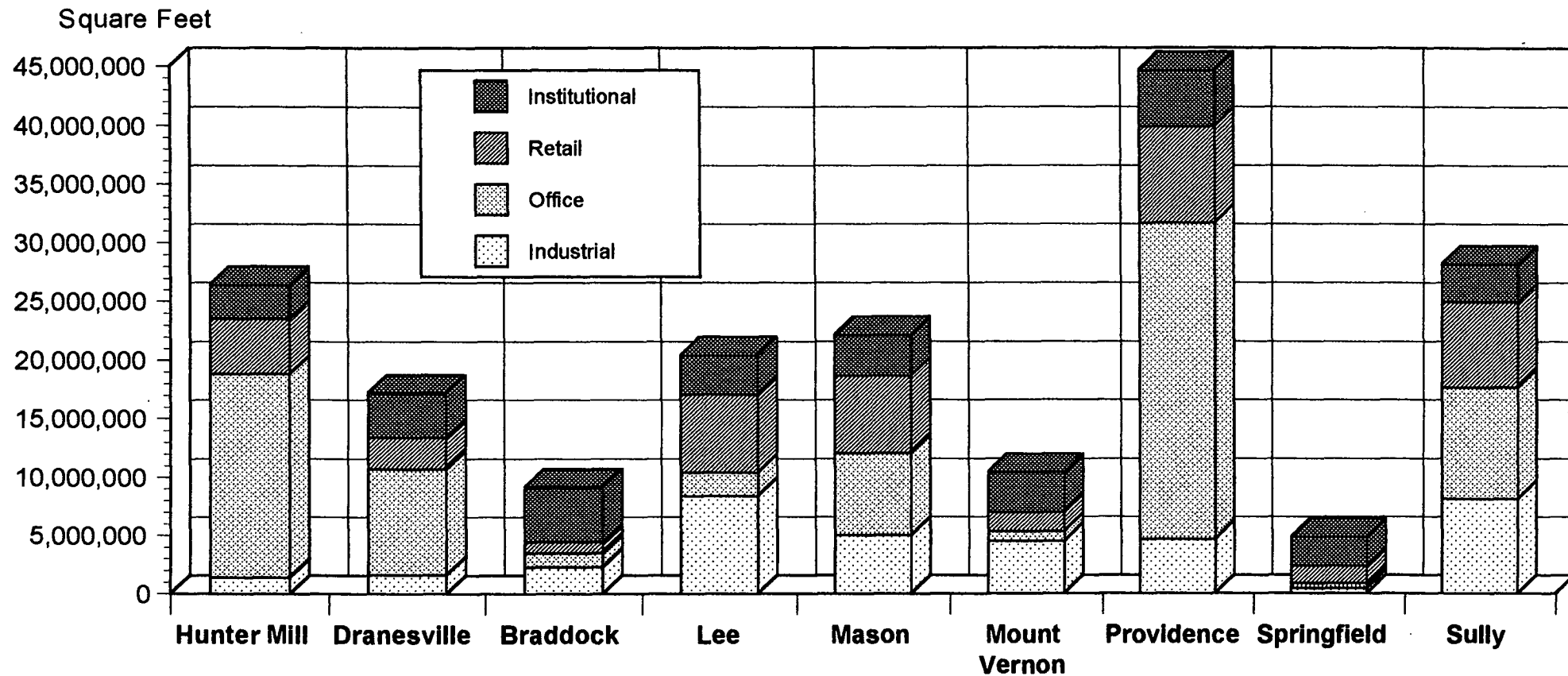

<b>Industrial</b>	1,388,182	1,618,407	2,249,124	8,348,313	4,969,100	4,440,968	4,619,854	413,691	8,114,856
<b>Office</b>	17,423,141	9,071,392	1,200,916	2,044,557	7,063,371	873,365	27,056,499	439,378	9,512,269
<b>Retail</b>	4,716,956	2,714,642	959,339	6,676,207	6,616,248	1,662,351	8,230,032	1,489,808	7,271,607
<b>Institutional</b>	2,875,635	3,764,383	4,678,460	3,322,512	3,485,253	3,389,012	4,747,677	2,481,001	3,267,511

Figure 2.6

# Average Annual Unemployment Rates and Total Employment Fairfax County, 1984 to 1994

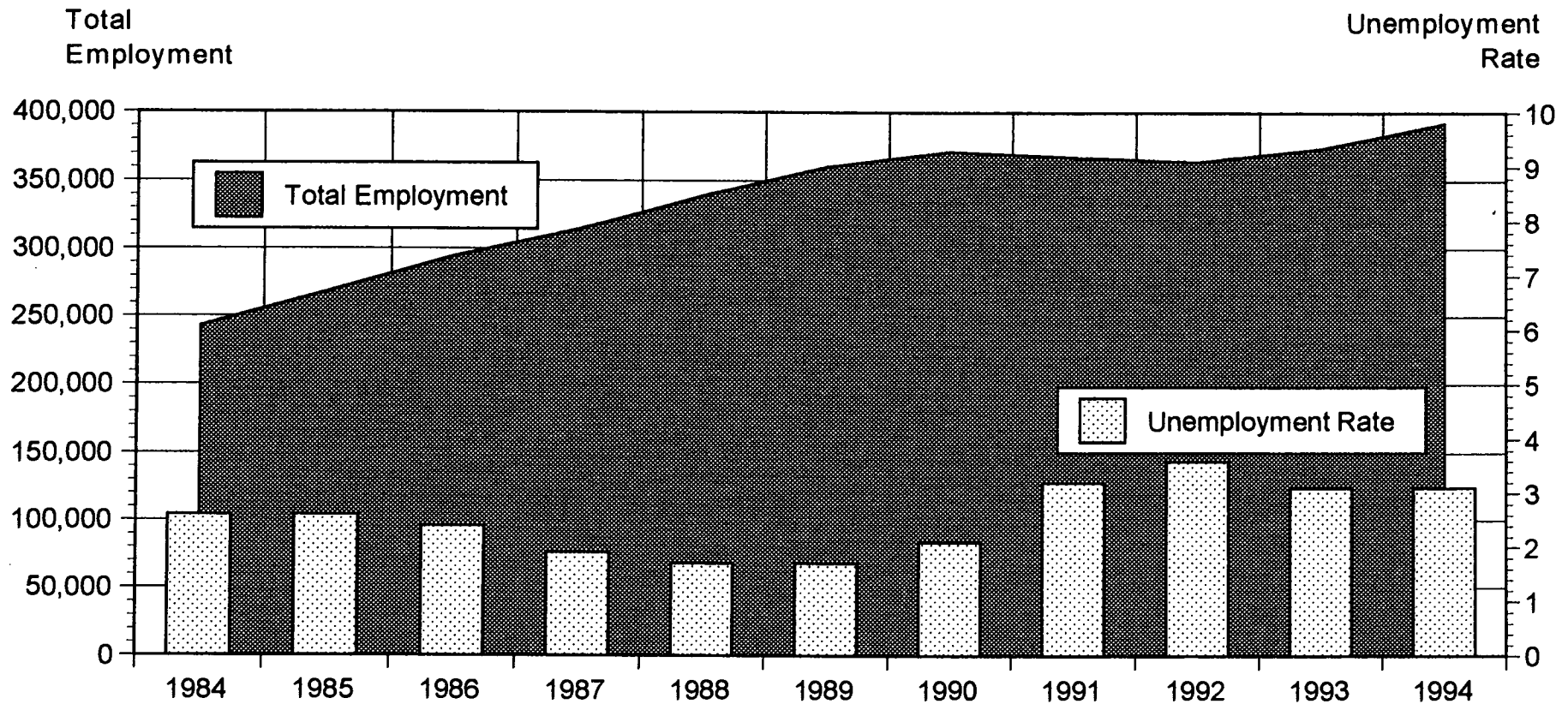

Total Employment	242,988	268,380	294,216	314,575	339,164	360,530	371,716	367,555	364,389	374,115	392,066
Unemployment Rate	2.6	2.6	2.4	1.9	1.7	1.7	2.1	3.2	3.6	3.1	3.1

Sources: U.S. Department of Labor, Bureau of Labor Statistics (unemployment rate);  
Virginia Employment Commission (total employment)

# III. CURRENT POPULATION

## CURRENT POPULATION

As of January 1995, there were an estimated 879,401 persons residing in Fairfax County. The County's population has increased by 16,267 persons, or 1.9 percent, over the 1994 population estimate of 863,134.

Among the nine supervisor districts, the Sully District is the largest in terms of total population (120,316 persons), while the Springfield District is largest in terms of total acreage (40,965 acres). The Braddock and Mason Districts have the lowest total populations with 89,824 persons and 89,855 persons, respectively.

The population density for the entire County is approximately 3.8 persons per acre, or 2,454 persons per square mile. The Springfield District has the lowest population density among supervisor districts -- 2.4 persons per acre. The Mason and Braddock Districts have the highest population densities, 7.9 persons per acre in Mason and 7.5 persons per acre in Braddock. Population density is based on the total acres in the County, excluding roads and water areas.

### Methodology

The current population information is summarized by supervisor district, and planning district, sewershed, and census and subcensus tract. Population estimates are developed for these specific geographical areas by applying vacancy rates and household size factors by dwelling unit type for the applicable planning district to the current housing inventory of the geographical area. Specifically, the housing unit type categories of single family, townhouse / condominium, and rental multifamily are multiplied by their corresponding vacancy rates. This generates the number of vacant housing units, which when subtracted from the total number of housing units yields the number of occupied housing units, or households, by unit type and by each geographical unit. The household figures are multiplied by the average household size figure for the dwelling unit type and planning district. This generates a population figure for each of the housing unit types which, when combined, reflect the composite population for a particular geographical entity.

The 1995 vacancy rates for each planning district were obtained from a combination of the analysis of 1994 water accounts from the Fairfax County Water Authority and from localities serving Fairfax County dwelling units, and the 1995 Rental Housing Census. The rental complex and non-rental complex vacancy rates are shown in Table 3.1.

The household size factors used for the population estimates were obtained based on the results of the 1994 Household Survey and regression analysis of factors related to household size. The household size factors used for each planning district and dwelling unit type are presented in Table 3.1. Figure 3.1 depicts the relationship between Fairfax County, the United States and the United States South region average household sizes from 1966 to 1995.

Table 3.2 shows the special institutional population from 1982 to 1995. The population of special institutions, such as Fort Belvoir and the District of Columbia Correctional Complex at Lorton, is obtained directly from these institutions. Additionally, "Other" special populations identified include the Fairfax County Adult Detention Center, George Mason University dormitories, and various nursing homes throughout the County. As of January 1995, the total population of all special institutions in Fairfax County was 20,220.

Population density for the County is presented in Figure 3.2. Each dot on the map represents ten persons. More lightly dotted areas of the map correspond to lower population densities. The map shows highest population densities in the Falls Church, Baileys Crossroads, Seven Corners, Huntington and Route 1 areas.

TABLE 3.1

**Average Household Size and Vacancy Rate By Planning District  
Fairfax County, 1995**

Planning District	Average Household Size (Persons per Occupied Unit)					Vacancy Rate			
	Single Family	Townhouse	Multi-Family	Mobile Home	Overall	Non-Rental Complex Units		Rental Complex Units	Overall
						Single Family	Townhouse / Condominium		
Annandale	2.92	2.47	2.26		2.70	0.9	0.2	2.7	1.0
Baileys	2.70	2.36	2.07		2.28	1.4	1.9	4.9	2.7
Bull Run	3.31	2.58	1.93	2.23	2.78	4.8	5.8	6.0	5.3
Fairfax	3.16	2.30	2.07	2.09	2.59	4.8	5.8	4.2	4.9
Jefferson	2.83	2.69	2.17		2.55	1.7	4.9	4.7	3.4
Lincolnia	2.82	1.95	2.58		2.44	2.0	0.0	2.7	1.7
Lower Potomac	2.85	2.71	2.19		2.62	5.7	6.4	23.0	11.0
McLean	3.06	2.43	1.67		2.68	2.6	3.8	6.3	3.3
Mount Vernon	2.88	2.36	1.93	2.49	2.42	1.5	0.6	4.1	2.0
Pohick	3.37	2.65	1.76		3.07	2.5	0.7	3.5	1.9
Rose Hill	2.89	2.23	1.86		2.47	4.8	2.5	4.5	3.8
Springfield	3.28	2.59	2.26		2.93	2.0	4.7	2.1	3.1
Upper Potomac	3.29	2.61	2.08		2.88	4.6	2.6	5.4	4.0
Vienna	2.98	2.25	2.14		2.72	5.2	6.3	3.8	5.3
<b>Fairfax County</b>	<b>3.11</b>	<b>2.51</b>	<b>2.04</b>	<b>2.38</b>	<b>2.71</b>	<b>3.1</b>	<b>3.1</b>	<b>4.9</b>	<b>3.4</b>

Source: Fairfax County Office of Management and Budget.

Figure 3.1

# Average Household Size

*Fairfax County, U.S. South Region, and the U.S., 1966 to 1995*

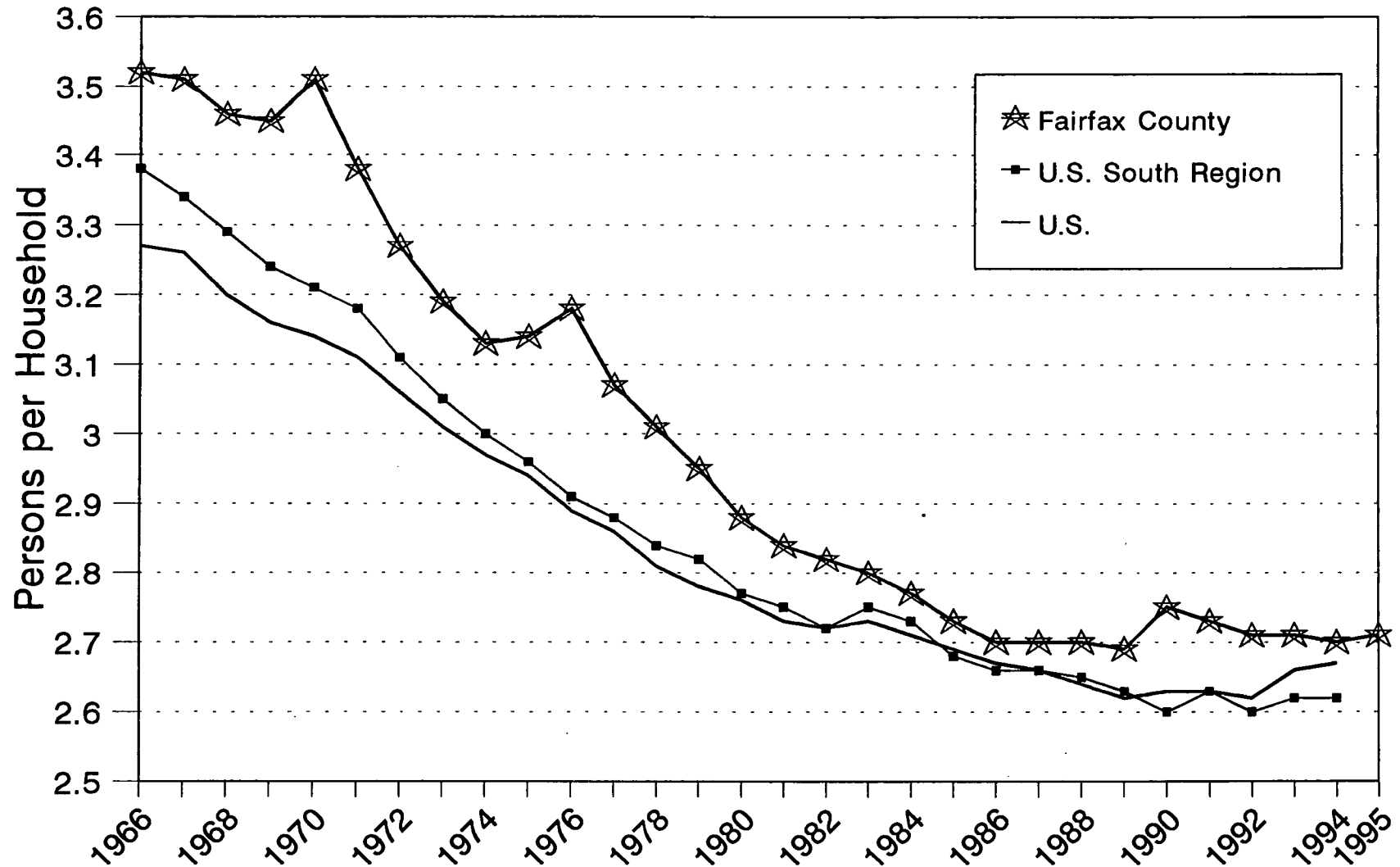

Sources: U.S. Bureau of the Census; Fairfax County Office of Management and Budget.



TABLE 3.2

**Special Institutional Population**  
**Fairfax County, 1982 -1995**

Year	D.C. Correctional Complex at Lorton		Fort Belvoir		Other		Total	
	Population	Percent Change	Population	Percent Change	Population	Percent Change	Population	Percent Change
1982	2,525	---	9,563	---			12,088	---
1983	2,837	12.4%	8,482	-11.3%			11,319	-6.4%
1984	3,256	14.8%	10,934	28.9%			14,190	25.4%
1985	3,537	8.6%	12,247	12.0%			15,784	11.2%
1986	4,327	22.3%	9,393	-23.3%			13,720	-13.1%
1987	4,651	7.5%	9,075	-3.4%			13,726	0.0%
1988	5,462	17.4%	9,334	2.9%			14,796	7.8%
1989	6,064	11.0%	10,027	7.4%			16,091	8.8%
1990	5,548	-8.5%	8,590	-14.3%	5,372	---	19,510	21.2% <sup>a</sup>
1991	6,225	12.2%	7,575	-11.8%	5,643	5.0%	19,443	-0.3%
1992	6,904	10.9%	6,634	-12.4%	5,574	-1.2%	19,112	-1.7%
1993	7,025	1.8%	6,426	-3.1%	6,142	10.2%	19,593	2.5%
1994	7,278	3.6%	6,803	5.9%	6,243	1.6%	20,324	3.7%
1995	7,281	0.0%	6,723	-1.2%	6,216	-0.4%	20,220	-0.5%

Sources: District of Columbia Department of Corrections; U.S. Department of the Army; U.S. Bureau of the Census, U.S. Census of Population and Housing 1990; Fairfax County Office of the Sheriff.

Note: "Other" includes the Fairfax County Adult Detention, Juvenile Detention, Pre-Release Centers, Nursing Homes and George Mason University dormitories.

<sup>a</sup> Percent change includes "Other" population not previously enumerated.

# Current Population Density

## January 1995

Fairfax County, Virginia

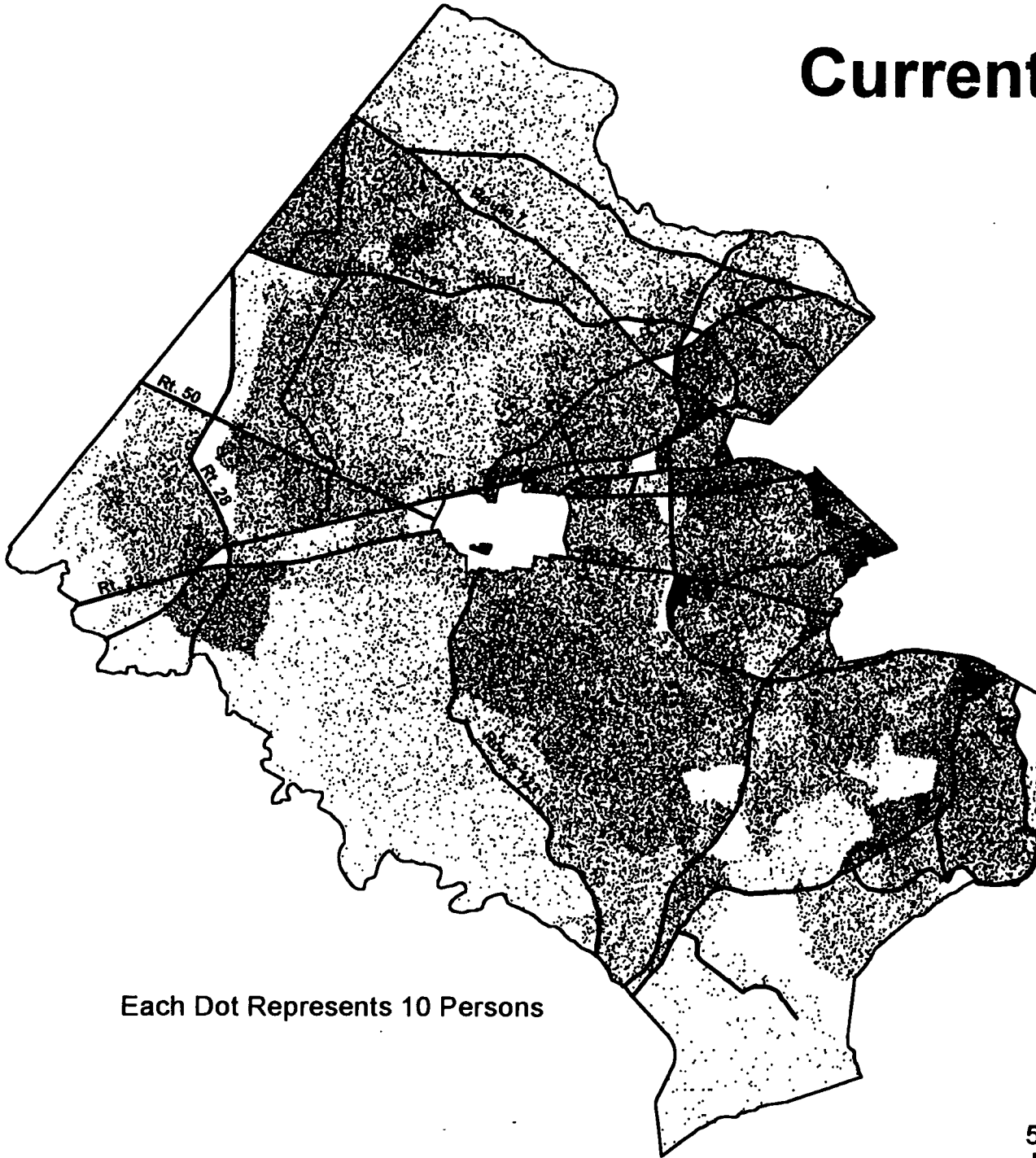
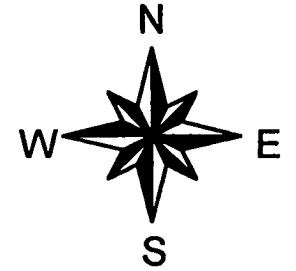

Each Dot Represents 10 Persons

Source: Urban Development Information System,  
Office of Management and Budget.



Population  
Supervisor District  
(January 1995)

Supervisor District	Population	Acres	Population per Acre	Square Miles	Population per Sq Mile
Braddock	89,824	12,006	7.5	18.76	4,788
Dranesville 1/	97,924	36,027	2.7	56.29	1,740
Hunter Mill 2/	97,934	21,824	4.5	34.10	2,872
Lee	93,513	16,592	5.6	25.93	3,607
Mason	89,855	11,370	7.9	17.77	5,058
Mount Vernon	96,114	36,634	2.6	57.24	1,679
Providence	95,314	14,363	6.6	22.44	4,247
Springfield 3/	98,607	40,965	2.4	64.01	1,541
Sully	120,316	39,588	3.0	61.86	1,945
FAIRFAX COUNTY	879,401	229,370	3.8	358.39	2,454

Population  
Towns  
(January 1995)

Town	Population	Acres	Population per Acre	Square Miles	Population per Sq Mile
Town of Clifton	222	140	1.6	0.22	1,015
Town of Herndon	16,737	2,338	7.2	3.65	4,581
Town of Vienna	14,838	2,390	6.2	3.73	3,973
TOWNS TOTAL	31,798	4,868	6.5	7.61	4,180

Note: The 1990 Census population for the City of Falls Church and the City of Fairfax is 9,578 and 19,622, respectively.

- 1/ Includes the Town of Herndon.
- 2/ Includes the Town of Vienna.
- 3/ Includes the Town of Clifton.

Population  
Planning District  
(January 1995)

Planning District	Population	Acres	Population per Acre	Square Miles	Population per Sq Mile
Annandale	67,635	10,085	6.7	15.76	4,292
Baileys	37,499	3,436	10.9	5.37	6,983
Bull Run	87,641	29,112	3.0	45.49	1,927
Fairfax	50,524	11,470	4.4	17.92	2,819
Jefferson	45,167	5,181	8.7	8.10	5,576
Lincolnia	13,388	1,732	7.7	2.71	4,940
Lower Potomac	25,830	23,625	1.1	36.91	700
McLean	62,566	16,466	3.8	25.73	2,432
Mount Vernon	85,539	11,863	7.2	18.54	4,614
Pohick 1/	132,049	45,741	2.9	71.47	1,848
Rose Hill	38,692	8,182	4.7	12.78	3,028
Springfield	43,240	8,888	4.9	13.89	3,113
Upper Potomac 2/	138,227	43,292	3.2	67.64	2,044
Vienna 3/	51,402	10,300	5.0	16.09	3,195
FAIRFAX COUNTY	879,401	229,370	3.8	358.39	2,454

Note: The 1990 Census population for the City of Falls Church and the City of Fairfax is 9,578 and 19,622, respectively.

- 1/ Includes the Town of Clifton.
- 2/ Includes the Town of Herndon.
- 3/ Includes the Town of Vienna.

Population  
Sewershed  
(January 1995)

Sewershed Code	Population	Acres	Population per Acre	Square Miles	Population per Sq Mile
A1	20,629	4,127	5.0	6.45	3,198
A2	617	672	0.9	1.05	587
A3	2,080	261	8.0	0.41	5,073
B1	4,549	962	4.7	1.50	3,032
B2	16,709	3,110	5.4	4.86	3,438
B3	1,935	1,513	1.3	2.36	820
B5 1/	16,408	2,327	7.1	3.64	4,508
C1	2,812	4,828	0.6	7.54	373
C2	3,303	5,644	0.6	8.82	374
D1	7,666	6,160	1.2	9.63	796
D2	20,680	4,806	4.3	7.51	2,754
D3 2/	70,475	20,726	3.4	32.38	2,176
E1	12,785	3,186	4.0	4.98	2,567
E2	1,437	1,347	1.1	2.11	681
F	6,969	1,072	6.5	1.68	4,148
G1	32,961	4,641	7.1	7.25	4,546
G2	3,277	649	5.0	1.01	3,245
G3	2,062	1,964	1.0	3.07	672
G4	1,011	155	6.5	0.24	4,212
H1	12,509	968	12.9	1.51	8,284
H2	6,865	100	68.8	0.16	42,907
H3	549	55	9.9	0.09	6,096
I1	60,982	7,590	8.0	11.86	5,142
I2	3,346	494	6.8	0.77	4,345
I3	48,233	7,689	6.3	12.01	4,016
I4	120	48	2.5	0.08	1,497
I5	748	62	12.0	0.10	7,483

(CONTINUED)

Note: The 1990 Census population for the City of Falls Church and the City of Fairfax is 9,578 and 19,622, respectively.

- 1/ Town of Herndon.
- 2/ Comprises part of the Town of Vienna
- 3/ Town of Clifton.

Population  
Sewershed  
(January 1995)

Sewershed Code	Population	Acres	Population per Acre	Square Miles	Population per Sq Mile
J1	19,040	2,124	9.0	3.32	5,735
J2	6,937	503	13.8	0.79	8,781
J3	4,901	637	7.7	1.00	4,901
J4	4,910	702	7.0	1.10	4,464
K	40,934	6,352	6.4	9.93	4,122
L	39,017	7,858	5.0	12.28	3,177
M0	6,110	581	10.5	0.91	6,714
M1	9,227	737	12.5	1.15	8,023
M2 2/	60,381	8,704	6.9	13.60	4,440
M3	18,511	2,765	6.7	4.32	4,285
M4	22,336	3,628	6.2	5.67	3,939
M5	7,562	2,220	3.4	3.47	2,179
M6	10,722	3,400	3.2	5.31	2,019
M7	414	28	14.8	0.04	10,362
M8	6,781	8,426	0.8	13.17	515
M9	5,385	1,392	3.9	2.18	2,470
N1	108,434	14,499	7.5	22.65	4,787
N2	16,682	4,575	3.6	7.15	2,333
O1	1,174	7,000	0.2	10.94	107
P	299	1,153	0.3	1.80	166
P1	191	854	0.2	1.33	143
P2	473	100	4.7	0.16	2,957
P3	2,639	840	3.1	1.31	2,014
Q1	14,381	19,156	0.8	29.93	480
R1	8,385	9,358	0.9	14.62	574
R2	729	339	2.2	0.53	1,376
R3 3/	225	149	1.5	0.23	979

(CONTINUED)

Note: The 1990 Census population for the City of Falls Church and the City of Fairfax is 9,578 and 19,622, respectively.

- 1/ Town of Herndon.
- 2/ Comprises part of the Town of Vienna
- 3/ Town of Clifton.

Population  
Sewershed  
(January 1995)

Sewershed Code	Population	Acres	Population per Acre	Square Miles	Population per Sq Mile
R4	753	565	1.3	0.88	856
S1	21,075	5,172	4.1	8.08	2,608
S2	697	2,592	0.3	4.05	172
T1	4,313	6,373	0.7	9.96	433
T2	17,397	3,926	4.4	6.14	2,833
T3	16,332	5,102	3.2	7.97	2,049
T4	16,642	2,295	7.3	3.59	4,636
T5	19,416	2,509	7.7	3.92	4,953
T6	169	4,110	0.0	6.42	26
T7	4,111	3,487	1.2	5.45	754
FAIRFAX COUNTY	879,401	229,370	3.8	358.39	2,454

Note: The 1990 Census population for the City of Falls Church and the City of Fairfax is 9,578 and 19,622, respectively.

- 1/ Town of Herndon.
- 2/ Comprises part of the Town of Vienna
- 3/ Town of Clifton.

Population  
Census and Subcensus Tract  
(January 1995)

Census Tract	Subcensus Tract	Population	Acres	Population per Acre.	Square Miles	Population per Sq Mile
151	151.01	1,316	163	8.1	0.26	5,063
	151.02	1,330	239	5.6	0.37	3,595
	151.03	870	89	9.8	0.14	6,212
	Census Tract Total	3,516	491	7.2	0.77	4,566
152	152.01	879	307	2.9	0.48	1,832
	152.02	2,888	171	16.9	0.27	10,695
	152.03	332	65	5.1	0.10	3,318
	152.04		72		0.11	
	Census Tract Total	4,099	615	6.7	0.96	4,269
153	153.01	771	91	8.4	0.14	5,504
	153.02	1,509	178	8.5	0.28	5,390
	153.03	1,187	67	17.7	0.10	11,867
	153.04	284	109	2.6	0.17	1,668
	Census Tract Total	3,750	446	8.4	0.70	5,357
154	154.01	5,245	525	10.0	0.82	6,396
	154.02	1,154	237	4.9	0.37	3,120
	154.03	983	102	9.7	0.16	6,145
	Census Tract Total	7,382	864	8.5	1.35	5,469
155	155.01	2,912	424	6.9	0.66	4,412
	155.02	1,951	266	7.3	0.42	4,646
	155.03	837	120	7.0	0.19	4,403
	155.04	255	27	9.4	0.04	6,381
	Census Tract Total	5,955	837	7.1	1.31	4,546
156	156.01	1,554	351	4.4	0.55	2,826
	156.02	223	43	5.2	0.07	3,187
	156.03	829	216	3.8	0.34	2,438
	156.04	324	558	0.6	0.87	373
	Census Tract Total	2,931	1,168	2.5	1.83	1,601
157	157.01	1,225	224	5.5	0.35	3,500
	157.02	2,118	355	6.0	0.56	3,783

(CONTINUED)



Population  
Census and Subcensus Tract  
(January 1995)

Census Tract	Subcensus Tract	Population	Acres	Population per Acre	Square Miles	Population per Sq Mile
157	157.03	546	342	1.6	0.53	1,031
	<b>Census Tract Total</b>	<b>3,890</b>	<b>921</b>	<b>4.2</b>	<b>1.44</b>	<b>2,701</b>
158	158.01	1,894	259	7.3	0.40	4,736
	158.02	1,502	242	6.2	0.38	3,953
	158.03	1,309	266	4.9	0.42	3,117
	<b>Census Tract Total</b>	<b>4,706</b>	<b>767</b>	<b>6.1</b>	<b>1.20</b>	<b>3,922</b>
159	159.01	2,412	576	4.2	0.90	2,681
	159.02	535	235	2.3	0.37	1,447
	159.03		119		0.19	
	159.04	354	193	1.8	0.30	1,182
	<b>Census Tract Total</b>	<b>3,302</b>	<b>1,122</b>	<b>2.9</b>	<b>1.75</b>	<b>1,887</b>
160	160.01	631	195	3.2	0.30	2,105
	160.02	2,467	328	7.5	0.51	4,837
	160.03	839	208	4.0	0.33	2,541
	<b>Census Tract Total</b>	<b>3,937</b>	<b>731</b>	<b>5.4</b>	<b>1.14</b>	<b>3,453</b>
161	161.01	482	414	1.2	0.65	742
	161.02	274	61	4.5	0.09	3,046
	161.03	1,768	460	3.8	0.72	2,455
	161.04	1,307	343	3.8	0.54	2,421
	<b>Census Tract Total</b>	<b>3,832</b>	<b>1,277</b>	<b>3.0</b>	<b>2.00</b>	<b>1,916</b>
162	162.01	5,580	2,766	2.0	4.32	1,292
	162.02		2,005		3.13	
	<b>Census Tract Total</b>	<b>5,580</b>	<b>4,771</b>	<b>1.2</b>	<b>7.45</b>	<b>749</b>
163	163.01	669	2,354	0.3	3.68	182
	163.02	1,260	6,699	0.2	10.47	120
	<b>Census Tract Total</b>	<b>1,929</b>	<b>9,054</b>	<b>0.2</b>	<b>14.15</b>	<b>136</b>
201	201.01	1,401	132	10.6	0.21	6,672
	201.02	1,846	556	3.3	0.87	2,122
	<b>Census Tract Total</b>	<b>3,247</b>	<b>689</b>	<b>4.7</b>	<b>1.08</b>	<b>3,006</b>
202	202.01	2,947	482	6.1	0.75	3,929

(CONTINUED)

Population  
Census and Subcensus Tract  
(January 1995)

Census Tract	Subcensus Tract	Population	Acres	Population per Acre	Square Miles	Population per Sq Mile
202	202.02	2,154	429	5.0	0.67	3,215
	Census Tract Total	5,101	911	5.6	1.42	3,592
203	203.01	1,755	282	6.2	0.44	3,988
	203.02	1,684	368	4.6	0.57	2,954
	203.03	666	91	7.3	0.14	4,757
	203.04	752	150	5.0	0.23	3,269
	Census Tract Total	4,857	890	5.5	1.39	3,494
204	204.01	3,090	126	24.6	0.20	15,452
	Census Tract Total	3,090	126	24.6	0.20	15,452
205	205.01	6,176	200	30.9	0.31	19,923
	205.02	504	35	14.2	0.06	8,392
	Census Tract Total	6,680	235	28.4	0.37	18,053
206	206.01	449	39	11.6	0.06	7,484
	206.02	961	40	24.3	0.06	16,011
	206.03	2,361	210	11.3	0.33	7,153
	Census Tract Total	3,770	288	13.1	0.45	8,379
207	207.01	1,720	259	6.6	0.41	4,195
	207.02	355	98	3.6	0.15	2,367
	207.03	1,508	245	6.2	0.38	3,969
	Census Tract Total	3,583	602	5.9	0.94	3,812
208	208.01	922	247	3.7	0.39	2,364
	208.02	729	81	9.0	0.13	5,610
	208.03	1,482	233	6.4	0.36	4,118
	Census Tract Total	3,134	561	5.6	0.88	3,561
210	210.01	900	465	1.9	0.73	1,233
	210.02	1,636	136	12.0	0.21	7,789
	210.03	730	222	3.3	0.35	2,086
	210.04	922	484	1.9	0.76	1,213
	Census Tract Total	4,188	1,307	3.2	2.04	2,053
211	211.01	5,564	1,120	5.0	1.75	3,180

(CONTINUED)

Population  
Census and Subcensus Tract  
(January 1995)

Census Tract	Subcensus Tract	Population	Acres	Population per Acre	Square Miles	Population per Sq Mile
211	211.02	3,232	890	3.6	1.39	2,325
	211.03	482	126	3.8	0.20	2,408
	Census Tract Total	9,278	2,137	4.3	3.34	2,778
212	212.01	1,901	486	3.9	0.76	2,501
	Census Tract Total	1,901	486	3.9	0.76	2,501
213	213.01	3,461	384	9.0	0.60	5,769
	213.02	250	1,545	0.2	2.41	104
	Census Tract Total	3,712	1,929	1.9	3.01	1,233
214	214.01	1,915	192	10.0	0.30	6,384
	214.02	3,073	231	13.3	0.36	8,536
	Census Tract Total	4,988	424	11.8	0.66	7,558
215	215.01	4,473	400	11.2	0.62	7,215
	Census Tract Total	4,473	400	11.2	0.62	7,215
216	216.01	3,221	130	24.7	0.20	16,103
	216.02	1,133	135	8.4	0.21	5,397
	Census Tract Total	4,354	265	16.4	0.41	10,620
217	217.01	6,507	515	12.6	0.80	8,133
	Census Tract Total	6,507	515	12.6	0.80	8,133
218	218.01	4,378	369	11.8	0.58	7,548
	Census Tract Total	4,378	369	11.8	0.58	7,548
219	219.01	1,143	3,416	0.3	5.34	214
	Census Tract Total	1,143	3,416	0.3	5.34	214
220	220.01	3	236	0.0	0.37	9
	220.02		261		0.41	
	220.03	1,288	275	4.7	0.43	2,995
	220.04	27	76	0.4	0.12	224
	220.05	414	28	14.8	0.04	10,362
	Census Tract Total	1,732	876	2.0	1.37	1,265
221	221.01	3,930	643	6.1	1.00	3,930
	221.02	3	216	0.0	0.34	8

(CONTINUED)

Population  
Census and Subcensus Tract  
(January 1995)

Census Tract	Subcensus Tract	Population	Acres	Population per Acre	Square Miles	Population per Sq Mile
221	221.03	1,051	752	1.4	1.18	890
	221.04	2,486	464	5.4	0.73	3,405
	221.05	596	516	1.2	0.81	736
	221.06	102	425	0.2	0.66	155
	Census Tract Total	8,168	3,017	2.7	4.71	1,734
222	222.01	7,281	2,988	2.4	4.67	1,559
	Census Tract Total	7,281	2,988	2.4	4.67	1,559
223	223.01	5,141	696	7.4	1.09	4,717
	Census Tract Total	5,141	696	7.4	1.09	4,717
224	224.01	6,825	1,060	6.4	1.66	4,111
	224.02	1,208	157	7.7	0.25	4,830
	Census Tract Total	8,032	1,217	6.6	1.90	4,227
301	301.01	1,528	286	5.3	0.45	3,396
	301.02	3,470	429	8.1	0.67	5,179
	301.03	2,796	213	13.1	0.33	8,474
	Census Tract Total	7,794	928	8.4	1.45	5,375
302	302.01	11,984	1,393	8.6	2.18	5,497
	Census Tract Total	11,984	1,393	8.6	2.18	5,497
304	304.01	4,106	964	4.3	1.51	2,719
	304.02	2,473	373	6.6	0.58	4,264
	Census Tract Total	6,579	1,338	4.9	2.09	3,148
305	305.01	1,640	211	7.8	0.33	4,969
	Census Tract Total	1,640	211	7.8	0.33	4,969
306	306.01	1,525	90	16.9	0.14	10,890
	306.02	1,125	75	15.0	0.12	9,372
	306.03	1,313	123	10.7	0.19	6,909
	306.04	1,397	171	8.1	0.27	5,173
	Census Tract Total	5,359	459	11.7	0.72	7,443
307	307.01	697	185	3.8	0.29	2,405
	307.02	1,086	207	5.2	0.32	3,394

(CONTINUED)

Population  
Census and Subcensus Tract  
(January 1995)

Census Tract	Subcensus Tract	Population	Acres	Population per Acre	Square Miles	Population per Sq Mile
307	307.03	1,198	210	5.7	0.33	3,629
	Census Tract Total	2,981	603	4.9	0.94	3,171
308	308.01	8,957	890	10.1	1.39	6,444
	Census Tract Total	8,957	890	10.1	1.39	6,444
309	309.01	6,306	863	7.3	1.35	4,671
	Census Tract Total	6,306	863	7.3	1.35	4,671
310	310.01	6,595	669	9.9	1.04	6,341
	Census Tract Total	6,595	669	9.9	1.04	6,341
313	313.01	4,378	533	8.2	0.83	5,275
	Census Tract Total	4,378	533	8.2	0.83	5,275
314	314.01	3,928	469	8.4	0.73	5,381
	Census Tract Total	3,928	469	8.4	0.73	5,381
315	315.01	5,773	849	6.8	1.33	4,340
	Census Tract Total	5,773	849	6.8	1.33	4,340
316	316.01	2,138	521	4.1	0.81	2,640
	316.02	2,493	331	7.5	0.52	4,795
	316.03	10	807	0.0	1.26	8
	Census Tract Total	4,641	1,659	2.8	2.59	1,792
318	318.01	6,934	738	9.4	1.15	6,030
	Census Tract Total	6,934	738	9.4	1.15	6,030
319	319.01	3,446	333	10.4	0.52	6,628
	Census Tract Total	3,446	333	10.4	0.52	6,628
320	320.01	3,232	324	10.0	0.51	6,338
	Census Tract Total	3,232	324	10.0	0.51	6,338
321	321.01	3,725	390	9.6	0.61	6,107
	Census Tract Total	3,725	390	9.6	0.61	6,107
322	322.01	6,677	713	9.4	1.11	6,015
	Census Tract Total	6,677	713	9.4	1.11	6,015
323	323.01	3,387	355	9.5	0.56	6,048
	323.02	1,372	288	4.8	0.45	3,050

(CONTINUED)

Population  
Census and Subcensus Tract  
(January 1995)

Census Tract	Subcensus Tract	Population	Acres	Population per Acre	Square Miles	Population per Sq Mile
323	Census Tract Total	4,760	643	7.4	1.01	4,712
324	324.01	8,303	952	8.7	1.49	5,572
	Census Tract Total	8,303	952	8.7	1.49	5,572
325	325.01	5,706	723	7.9	1.13	5,049
	Census Tract Total	5,706	723	7.9	1.13	5,049
326	326.01	4,683	641	7.3	1.00	4,683
	Census Tract Total	4,683	641	7.3	1.00	4,683
327	327.01	7,339	878	8.4	1.37	5,357
	Census Tract Total	7,339	878	8.4	1.37	5,357
328	328.01	2,045	688	3.0	1.08	1,894
	Census Tract Total	2,045	688	3.0	1.08	1,894
401	401.01	1,812	422	4.3	0.66	2,746
	401.02	3,068	596	5.2	0.93	3,299
	401.03	2,441	288	8.5	0.45	5,425
	Census Tract Total	7,322	1,305	5.6	2.04	3,589
402	402.01	614	296	2.1	0.46	1,334
	402.02	4,650	553	8.4	0.86	5,407
	402.03		118		0.18	
	402.04	394	214	1.8	0.33	1,194
	Census Tract Total	5,658	1,181	4.8	1.84	3,075
403	403.01	1,362	345	3.9	0.54	2,523
	403.02	1,292	304	4.3	0.47	2,749
	Census Tract Total	2,654	649	4.1	1.01	2,628
405	405.01	3,049	426	7.2	0.67	4,550
	405.02	1,305	219	6.0	0.34	3,837
	405.03	4,718	951	5.0	1.49	3,166
	405.04	1,084	48	22.5	0.08	13,550
	Census Tract Total	10,155	1,644	6.2	2.57	3,951
406	406.01	2,549	844	3.0	1.32	1,931
	Census Tract Total	2,549	844	3.0	1.32	1,931

(CONTINUED)

Population  
Census and Subcensus Tract  
(January 1995)

Census Tract	Subcensus Tract	Population	Acres	Population per Acre	Square Miles	Population per Sq Mile
407	407.01	5,139	726	7.1	1.13	4,548
	407.02	2,864	388	7.4	0.61	4,696
	<b>Census Tract Total</b>	<b>8,003</b>	<b>1,114</b>	<b>7.2</b>	<b>1.74</b>	<b>4,600</b>
408	408.01	2,392	353	6.8	0.55	4,348
	408.02	281	63	4.5	0.10	2,805
	408.03	1,263	226	5.6	0.35	3,609
	408.04	1,932	486	4.0	0.76	2,542
	408.05		229		0.36	
	<b>Census Tract Total</b>	<b>5,867</b>	<b>1,356</b>	<b>4.3</b>	<b>2.12</b>	<b>2,768</b>
501	501.01	3,279	265	12.4	0.41	7,997
	501.02	875	66	13.3	0.10	8,750
	501.03	1,106	100	11.1	0.16	6,912
	<b>Census Tract Total</b>	<b>5,260</b>	<b>431</b>	<b>12.2</b>	<b>0.67</b>	<b>7,850</b>
502	502.01	1,312	43	30.3	0.07	18,747
	502.02	675	58	11.7	0.09	7,497
	502.03	469	63	7.4	0.10	4,691
	502.04	1,091	101	10.8	0.16	6,817
	<b>Census Tract Total</b>	<b>3,547</b>	<b>265</b>	<b>13.4</b>	<b>0.41</b>	<b>8,651</b>
503	503.01	846	60	14.2	0.09	9,399
	503.02	818	63	12.9	0.10	8,180
	503.03	1,944	164	11.8	0.26	7,478
	503.04	631	63	10.0	0.10	6,309
	<b>Census Tract Total</b>	<b>4,239</b>	<b>350</b>	<b>12.1</b>	<b>0.55</b>	<b>7,707</b>
504	504.01	1,011	206	4.9	0.32	3,159
	504.02	940	140	6.7	0.22	4,275
	504.03	637	169	3.8	0.26	2,451
	<b>Census Tract Total</b>	<b>2,589</b>	<b>515</b>	<b>5.0</b>	<b>0.80</b>	<b>3,236</b>
505	505.01	1,001	80	12.4	0.13	7,700
	505.02	843	72	11.7	0.11	7,664
	505.03	623	52	12.0	0.08	7,791

(CONTINUED)

Population  
Census and Subcensus Tract  
(January 1995)

Census Tract	Subcensus Tract	Population	Acres	Population per Acre	Square Miles	Population per Sq Mile
505	Census Tract Total	2,467	205	12.1	0.32	7,710
506	506.01	531	177	3.0	0.28	1,898
	506.02	3,793	338	11.2	0.53	7,156
	506.03	829	82	10.1	0.13	6,378
	506.04	528	69	7.7	0.11	4,804
	506.05	715	116	6.2	0.18	3,973
	506.06	1,043	112	9.3	0.18	5,797
	506.07	483	61	7.9	0.10	4,832
	Census Tract Total	7,923	955	8.3	1.49	5,318
507	507.01	2,601	442	5.9	0.69	3,769
	507.02	3,352	260	12.9	0.41	8,175
	Census Tract Total	5,952	702	8.5	1.10	5,411
508	508.01	850	118	7.2	0.18	4,724
	508.02	1,303	171	7.6	0.27	4,826
	508.03	1,058	126	8.4	0.20	5,291
	Census Tract Total	3,212	415	7.7	0.65	4,941
509	509.01	796	165	4.8	0.26	3,061
	509.02	824	166	5.0	0.26	3,168
	Census Tract Total	1,619	331	4.9	0.52	3,114
510	510.01	1,186	127	9.3	0.20	5,929
	510.02	1,627	217	7.5	0.34	4,786
	Census Tract Total	2,813	344	8.2	0.54	5,210
511	511.01	958	168	5.7	0.26	3,686
	511.02	1,200	202	6.0	0.31	3,871
	Census Tract Total	2,158	369	5.8	0.58	3,721
512	512.01	602	176	3.4	0.28	2,149
	512.02	820	225	3.6	0.35	2,342
	512.03	264	101	2.6	0.16	1,647
	Census Tract Total	1,685	502	3.4	0.78	2,160
513	513.01	1,139	207	5.5	0.32	3,558

(CONTINUED)



Population  
Census and Subcensus Tract  
(January 1995)

Census Tract	Subcensus Tract	Population	Acres	Population per Acre	Square Miles	Population per Sq Mile
513	513.02	1,109	146	7.6	0.23	4,823
	Census Tract Total	2,248	352	6.4	0.55	4,087
514	514.01	414	15	26.8	0.02	20,713
	514.02	1,428	32	44.6	0.05	28,569
	514.03	679	52	13.0	0.08	8,491
	Census Tract Total	2,522	100	25.3	0.16	15,763
515	515.01	2,006	93	21.5	0.15	13,372
	515.02	2,824	166	17.0	0.26	10,862
	515.03	1,736	237	7.3	0.37	4,692
	515.04	1,986	141	14.1	0.22	9,025
	Census Tract Total	8,552	638	13.4	1.00	8,552
516	516.01	1,678	66	25.6	0.10	16,780
	516.02	213	30	7.2	0.05	4,259
	516.03	1,661	72	23.0	0.11	15,104
	516.04	1,316	109	12.0	0.17	7,743
	516.05	958	145	6.6	0.23	4,167
	Census Tract Total	5,827	422	13.8	0.66	8,829
518	518.01	1,221	164	7.4	0.26	4,697
	518.02	461	95	4.8	0.15	3,070
	518.03	1,132	205	5.5	0.32	3,538
	Census Tract Total	2,814	464	6.1	0.72	3,908
519	519.01	4,994	619	8.1	0.97	5,148
	Census Tract Total	4,994	619	8.1	0.97	5,148
520	520.01	2,926	492	5.9	0.77	3,800
	Census Tract Total	2,926	492	5.9	0.77	3,800
521	521.01	344	135	2.6	0.21	1,639
	521.02	2,520	375	6.7	0.59	4,272
	521.03	1,477	232	6.4	0.36	4,102
	521.04	1,647	266	6.2	0.42	3,921
	521.05	1,060	253	4.2	0.39	2,718

(CONTINUED)

Population  
Census and Subcensus Tract  
(January 1995)

Census Tract	Subcensus Tract	Population	Acres	Population per Acre	Square Miles	Population per Sq Mile
521	Census Tract Total	7,048	1,260	5.6	1.97	3,578
522	522.01	3,417	206	16.6	0.32	10,679
	522.02	1,107	164	6.7	0.26	4,258
	522.03	1,018	113	9.0	0.18	5,656
	Census Tract Total	5,542	483	11.5	0.75	7,390
523	523.01	7,104	235	30.2	0.37	19,199
	Census Tract Total	7,104	235	30.2	0.37	19,199
524	524.01	1,466	165	8.9	0.26	5,640
	524.02	998	89	11.2	0.14	7,127
	524.03	821	83	9.8	0.13	6,318
	524.04	1,849	207	8.9	0.32	5,779
	524.05	1,216	177	6.9	0.28	4,344
	Census Tract Total	6,351	722	8.8	1.13	5,620
525	525.01	827	449	1.8	0.70	1,182
	525.02	1,116	313	3.6	0.49	2,277
	525.03	951	259	3.7	0.40	2,378
	525.04	3,837	246	15.6	0.38	10,096
	Census Tract Total	6,730	1,267	5.3	1.98	3,399
526	526.01	1,944	295	6.6	0.46	4,226
	526.02	1,075	191	5.6	0.30	3,584
	526.03	588	122	4.8	0.19	3,092
	Census Tract Total	3,607	608	5.9	0.95	3,796
527	527.01	3,720	327	11.4	0.51	7,294
	Census Tract Total	3,720	327	11.4	0.51	7,294
528	528.01	7,974	261	30.5	0.41	19,449
	Census Tract Total	7,974	261	30.5	0.41	19,449
601	601.01	1,006	485	2.1	0.76	1,324
	601.02	1,962	518	3.8	0.81	2,422
	601.03	775	426	1.8	0.67	1,157
	Census Tract Total	3,744	1,429	2.6	2.23	1,679

(CONTINUED)

Population  
Census and Subcensus Tract  
(January 1995)

Census Tract	Subcensus Tract	Population	Acres	Population per Acre	Square Miles	Population per Sq Mile
602	602.01	1,380	813	1.7	1.27	1,087
	602.02	175	167	1.0	0.26	674
	602.03	1,818	918	2.0	1.43	1,272
	Census Tract Total	3,374	1,898	1.8	2.97	1,136
603	603.01	681	189	3.6	0.30	2,269
	603.02	1,864	293	6.4	0.46	4,053
	Census Tract Total	2,545	483	5.3	0.75	3,393
604	604.01	664	237	2.8	0.37	1,794
	604.02	2,566	505	5.1	0.79	3,248
	604.03	427	91	4.7	0.14	3,047
	Census Tract Total	3,656	833	4.4	1.30	2,813
605	605.01	1,761	451	3.9	0.70	2,516
	605.02	1,630	234	7.0	0.37	4,405
	605.03	838	115	7.3	0.18	4,657
	605.04	489	97	5.1	0.15	3,258
	605.05	1,359	272	5.0	0.42	3,236
	Census Tract Total	6,077	1,168	5.2	1.82	3,339
606	606.01	415	89	4.7	0.14	2,966
	606.02	3,232	451	7.2	0.71	4,552
	Census Tract Total	3,647	540	6.8	0.84	4,342
607 /1	607.01	7,225	965	7.5	1.51	4,785
	Census Tract Total	7,225	965	7.5	1.51	4,785
608 /1	608.01	2,974	495	6.0	0.77	3,862
	Census Tract Total	2,974	495	6.0	0.77	3,862
609 /1	609.01	2,366	586	4.0	0.92	2,571
	Census Tract Total	2,366	586	4.0	0.92	2,571
610 /1	610.01	2,274	345	6.6	0.54	4,211
	Census Tract Total	2,274	345	6.6	0.54	4,211
611	611.01	1,807	551	3.3	0.86	2,101
	611.02	4,456	868	5.1	1.36	3,277

(CONTINUED)

Population  
Census and Subcensus Tract  
(January 1995)

Census Tract	Subcensus Tract	Population	Acres	Population per Acre	Square Miles	Population per Sq Mile
611	Census Tract Total	6,263	1,419	4.4	2.22	2,821
612	612.01	584	590	1.0	0.92	634
	612.02	3,016	1,732	1.7	2.71	1,113
	612.03	210	324	0.6	0.51	411
	612.04	30	311	0.1	0.49	61
	Census Tract Total	3,839	2,957	1.3	4.62	831
615	615.01	706	161	4.4	0.25	2,822
	615.02	761	105	7.3	0.16	4,757
	615.03	1,069	147	7.3	0.23	4,650
	615.04	1,330	216	6.1	0.34	3,911
	615.05	251	35	7.1	0.06	4,190
	Census Tract Total	4,117	665	6.2	1.04	3,959
616	616.01	1,511	246	6.1	0.38	3,977
	616.02	966	224	4.3	0.35	2,759
	616.04	1,644	96	17.0	0.15	10,960
	616.05	799	80	10.0	0.13	6,148
	616.06	6	196	0.0	0.31	18
	Census Tract Total	4,926	843	5.8	1.32	3,731
617	617.01	3,867	344	11.2	0.54	7,161
	617.02	446	171	2.6	0.27	1,653
	Census Tract Total	4,313	516	8.4	0.81	5,325
618	618.01	820	119	6.9	0.19	4,314
	618.02	4,636	249	18.6	0.39	11,887
	Census Tract Total	5,456	368	14.8	0.58	9,406
619	619.02	4,085	223	18.3	0.35	11,671
	Census Tract Total	4,085	223	18.3	0.35	11,671
701	701.01	838	269	3.1	0.42	1,995
	701.02	1,333	770	1.7	1.20	1,111
	701.03	176	94	1.9	0.15	1,173
	701.04	481	302	1.6	0.47	1,024

(CONTINUED)

Population  
Census and Subcensus Tract  
(January 1995)

Census Tract	Subcensus Tract	Population	Acres	Population per Acre	Square Miles	Population per Sq Mile
701	Census Tract Total	2,828	1,436	2.0	2.24	1,262
702	702.01	6	814	0.0	1.27	5
	Census Tract Total	6	814	0.0	1.27	5
703	703.01	1,987	378	5.3	0.59	3,368
	703.02	377	104	3.6	0.16	2,358
	703.03	892	197	4.5	0.31	2,876
	Census Tract Total	3,256	679	4.8	1.06	3,072
704	704.01	1,410	401	3.5	0.63	2,239
	704.02	128	44	2.9	0.07	1,832
	704.03	1,062	385	2.8	0.60	1,770
	704.04	769	195	4.0	0.30	2,564
	704.05	1,485	252	5.9	0.39	3,807
	Census Tract Total	4,855	1,277	3.8	2.00	2,427
705	705.01	328	77	4.2	0.12	2,733
	705.02	981	188	5.2	0.29	3,383
	705.03	1,941	327	5.9	0.51	3,805
	705.04	875	140	6.3	0.22	3,978
	705.05	468	70	6.7	0.11	4,256
	705.06	802	62	13.0	0.10	8,020
	Census Tract Total	5,395	865	6.2	1.35	3,996
706	706.01	534	214	2.5	0.33	1,617
	706.02	494	90	5.5	0.14	3,528
	706.03	1,005	102	9.9	0.16	6,283
	706.04	501	71	7.1	0.11	4,559
	Census Tract Total	2,534	477	5.3	0.75	3,379
707	707.01	845	155	5.5	0.24	3,522
	707.02	1,184	143	8.3	0.22	5,381
	707.03	834	145	5.7	0.23	3,627
	707.04	1,127	142	7.9	0.22	5,123
	707.05	584	78	7.5	0.12	4,870

(CONTINUED)

Population  
Census and Subcensus Tract  
(January 1995)

Census Tract	Subcensus Tract	Population	Acres	Population per Acre	Square Miles	Population per Sq Mile
707	707.06	766	78	9.8	0.12	6,386
	Census Tract Total	5,341	743	7.2	1.16	4,604
708	708.01	788	143	5.5	0.22	3,580
	708.02	2,222	278	8.0	0.43	5,168
	Census Tract Total	3,010	421	7.2	0.66	4,560
709	709.01	1,933	312	6.2	0.49	3,944
	709.02	2,095	217	9.7	0.34	6,161
	709.03	760	72	10.6	0.11	6,912
	709.04	815	175	4.7	0.27	3,019
	709.05	1,017	111	9.2	0.17	5,982
	709.06	313	27	11.5	0.04	7,827
	Census Tract Total	6,933	913	7.6	1.43	4,848
710	710.01	172	85	2.0	0.13	1,320
	710.02	656	115	5.7	0.18	3,644
	710.03	718	153	4.7	0.24	2,991
	Census Tract Total	1,545	353	4.4	0.55	2,810
711	711.01	508	44	11.5	0.07	7,255
	711.02	614	61	10.1	0.10	6,142
	711.03	796	79	10.1	0.12	6,634
	711.04	912	80	11.5	0.12	7,603
	711.05	731	65	11.2	0.10	7,305
	711.06	1,530	150	10.2	0.23	6,651
	711.07	567	77	7.3	0.12	4,721
	711.08	1,094	185	5.9	0.29	3,773
	Census Tract Total	6,752	741	9.1	1.16	5,820
712	712.01	3	75	0.0	0.12	25
	712.02		61		0.10	
	712.03	547	31	17.7	0.05	10,948
	712.04	4,756	316	15.0	0.49	9,707
	Census Tract Total	5,307	484	11.0	0.76	6,983

(CONTINUED)

Population  
Census and Subcensus Tract  
(January 1995)

Census Tract	Subcensus Tract	Population	Acres	Population per Acre	Square Miles	Population per Sq Mile
713	713.01	7,310	442	16.5	0.69	10,594
	713.02	1,667	249	6.7	0.39	4,274
	Census Tract Total	8,977	691	13.0	1.08	8,312
714	714.01	4,256	624	6.8	0.97	4,388
	714.02	2,026	108	18.7	0.17	11,919
	Census Tract Total	6,283	732	8.6	1.14	5,511
801	801.01	1,171	3,217	0.4	5.03	233
	801.02	680	788	0.9	1.23	553
	801.03	652	1,210	0.5	1.89	345
	801.04	814	2,011	0.4	3.14	259
	801.05	605	1,352	0.4	2.11	287
	Census Tract Total	3,922	8,577	0.5	13.40	293
802	802.01	939	709	1.3	1.11	846
	802.02	1,336	434	3.1	0.68	1,964
	802.03	1,527	255	6.0	0.40	3,817
	802.04	3,445	535	6.4	0.84	4,102
	802.05		128		0.20	
	Census Tract Total	7,247	2,062	3.5	3.22	2,251
803	803.01	2,684	2,456	1.1	3.84	699
	803.02	745	541	1.4	0.84	887
	803.03	2,460	1,790	1.4	2.80	879
	803.04	3	92	0.0	0.14	21
	Census Tract Total	5,893	4,879	1.2	7.62	773
804	804.01	1,854	1,454	1.3	2.27	817
	804.02	1,983	2,421	0.8	3.78	525
	804.03	1,157	1,099	1.1	1.72	673
	804.04	1,141	723	1.6	1.13	1,010
	804.05	2,423	1,256	1.9	1.96	1,236
	Census Tract Total	8,558	6,954	1.2	10.87	787
805	805.01	5,307	609	8.7	0.95	5,586

(CONTINUED)

Population  
Census and Subcensus Tract  
(January 1995)

Census Tract	Subcensus Tract	Population	Acres	Population per Acre	Square Miles	Population per Sq Mile
805	805.02	5,310	1,300	4.1	2.03	2,616
	805.03	5,327	882	6.0	1.38	3,860
	Census Tract Total	15,944	2,791	5.7	4.36	3,657
808 /2	808.01	6,805	1,038	6.6	1.62	4,201
	Census Tract Total	6,805	1,038	6.6	1.62	4,201
809 /2	809.01	9,932	1,300	7.6	2.03	4,893
	Census Tract Total	9,932	1,300	7.6	2.03	4,893
810	810.01	2,655	295	9.0	0.46	5,772
	Census Tract Total	2,655	295	9.0	0.46	5,772
811	811.01	94	250	0.4	0.39	241
	811.02	2,231	578	3.9	0.90	2,479
	811.03	3,330	465	7.2	0.73	4,561
	811.04	3,979	731	5.4	1.14	3,491
	Census Tract Total	9,634	2,024	4.8	3.16	3,049
812	812.01	6,078	1,058	5.7	1.65	3,684
	Census Tract Total	6,078	1,058	5.7	1.65	3,684
814	814.01	7,236	1,227	5.9	1.92	3,769
	Census Tract Total	7,236	1,227	5.9	1.92	3,769
815	815.01	2,395	1,124	2.1	1.76	1,361
	Census Tract Total	2,395	1,124	2.1	1.76	1,361
816	816.01	1,452	974	1.5	1.52	955
	816.02	1,675	1,098	1.5	1.72	974
	Census Tract Total	3,127	2,072	1.5	3.24	965
817	817.01	1,717	872	2.0	1.36	1,262
	817.02	1,701	884	1.9	1.38	1,233
	817.03	1,852	633	2.9	0.99	1,871
	817.04	3,886	609	6.4	0.95	4,090
	Census Tract Total	9,155	2,998	3.1	4.69	1,952
819	819.01	3,284	1,390	2.4	2.17	1,513
	819.02	1,444	1,077	1.3	1.68	859

(CONTINUED)



Population  
Census and Subcensus Tract  
(January 1995)

Census Tract	Subcensus Tract	Population	Acres	Population per Acre	Square Miles	Population per Sq Mile
819	Census Tract Total	4,727	2,466	1.9	3.85	1,228
820	820.01	5,309	1,185	4.5	1.85	2,870
	820.02	1,297	173	7.5	0.27	4,804
	Census Tract Total	6,606	1,358	4.9	2.12	3,116
821	821.01	3,400	207	16.4	0.32	10,624
	Census Tract Total	3,400	207	16.4	0.32	10,624
822	822.01	853	426	2.0	0.66	1,292
	822.02	960	330	2.9	0.52	1,847
	822.03	4,367	328	13.3	0.51	8,563
	Census Tract Total	6,180	1,083	5.7	1.69	3,657
823	823.01	13,317	1,276	10.4	1.99	6,692
	Census Tract Total	13,317	1,276	10.4	1.99	6,692
824	824.01	1,955	904	2.2	1.41	1,387
	Census Tract Total	1,955	904	2.2	1.41	1,387
825	825.01	678	1,810	0.4	2.83	240
	825.02	11,519	1,857	6.2	2.90	3,972
	Census Tract Total	12,197	3,667	3.3	5.73	2,129
826	826.01	1,889	398	4.7	0.62	3,047
	826.02	7,848	1,709	4.6	2.67	2,939
	Census Tract Total	9,737	2,107	4.6	3.29	2,960
901	901.01	13	564	0.0	0.88	14
	901.02	38	438	0.1	0.68	56
	901.03	2,782	1,755	1.6	2.74	1,015
	901.04	3	965	0.0	1.51	2
	901.05	6,545	1,553	4.2	2.43	2,693
	901.06		2,501		3.91	
	Census Tract Total	9,381	7,775	1.2	12.15	772
905	905.01	2,605	245	10.7	0.38	6,856
	905.02	5,037	2,131	2.4	3.33	1,513
	Census Tract Total	7,642	2,375	3.2	3.71	2,060

(CONTINUED)

Population  
Census and Subcensus Tract  
(January 1995)

Census Tract	Subcensus Tract	Population	Acres	Population per Acre	Square Miles	Population per Sq Mile
909 /3	909.01	222	140	1.6	0.22	1,009
	Census Tract Total	222	140	1.6	0.22	1,009
910	910.01	24	1,597	0.0	2.49	10
	910.02	1,567	2,784	0.6	4.35	360
	Census Tract Total	1,591	4,381	0.4	6.84	233
911	911.01	11,836	3,055	3.9	4.77	2,481
	Census Tract Total	11,836	3,055	3.9	4.77	2,481
912	912.01	5,198	435	12.0	0.68	7,645
	912.02		124		0.19	
	Census Tract Total	5,198	559	9.3	0.87	5,975
913	913.01	69	803	0.1	1.25	55
	913.02	113	1,575	0.1	2.46	46
	913.03	1,373	839	1.6	1.31	1,048
	913.04	7,527	976	7.7	1.52	4,952
	Census Tract Total	9,083	4,193	2.2	6.55	1,387
914	914.01	15,264	1,666	9.2	2.60	5,871
	Census Tract Total	15,264	1,666	9.2	2.60	5,871
915	915.01	4,539	1,261	3.6	1.97	2,304
	915.02	1,467	492	3.0	0.77	1,906
	915.03	314	35	8.9	0.06	5,234
	Census Tract Total	6,320	1,788	3.5	2.79	2,265
916	916.01	7,045	886	7.9	1.38	5,105
	Census Tract Total	7,045	886	7.9	1.38	5,105
917	917.01	3,354	492	6.8	0.77	4,356
	917.02	1,477	238	6.2	0.37	3,993
	917.03	518	761	0.7	1.19	435
	917.04	2,479	621	4.0	0.97	2,555
	Census Tract Total	7,828	2,112	3.7	3.30	2,372
918	918.01	10,408	1,179	8.8	1.84	5,657
	Census Tract Total	10,408	1,179	8.8	1.84	5,657

(CONTINUED)

Population  
Census and Subcensus Tract  
(January 1995)

Census Tract	Subcensus Tract	Population	Acres	Population per Acre	Square Miles	Population per Sq Mile
919	919.01	342	1,235	0.3	1.93	177
	919.02	407	984	0.4	1.54	265
	919.03	493	1,110	0.4	1.73	285
	919.04	184	273	0.7	0.43	428
	919.05	375	2,490	0.2	3.89	96
	919.06	131	334	0.4	0.52	253
	919.07	306	1,767	0.2	2.76	111
	919.08	56	106	0.5	0.17	329
	919.09	373	677	0.6	1.06	352
	919.10	141	193	0.7	0.30	471
	919.11	151	1,315	0.1	2.06	73
	919.12	297	496	0.6	0.78	381
		Census Tract Total	3,257	10,981	0.3	17.16
920	920.01	2,143	1,932	1.1	3.02	709
	920.02	2,151	2,235	1.0	3.49	616
	920.03	2,202	1,332	1.7	2.08	1,058
		Census Tract Total	6,495	5,499	1.2	8.59
921	921.01	269	490	0.5	0.77	350
	921.02	417	763	0.5	1.19	351
	921.03	1,088	2,020	0.5	3.16	344
	921.04	723	633	1.1	0.99	730
	921.05	905	658	1.4	1.03	879
	921.06	1,160	1,192	1.0	1.86	624
	921.07	2,455	1,446	1.7	2.26	1,086
		Census Tract Total	7,018	7,203	1.0	11.25
922	922.01	380	2,649	0.1	4.14	92
	922.02	1,428	2,979	0.5	4.65	307
	922.03	6,032	1,279	4.7	2.00	3,016
	922.04	652	1,738	0.4	2.72	240
	922.05	3,332	1,053	3.2	1.65	2,019

(CONTINUED)

Population  
Census and Subcensus Tract  
(January 1995)

Census Tract	Subcensus Tract	Population	Acres	Population per Acre	Square Miles	Population per Sq Mile
922	Census Tract Total	11,824	9,698	1.2	15.15	780
923	923.01	3,251	534	6.1	0.83	3,916
	Census Tract Total	3,251	534	6.1	0.83	3,916
924	924.01	4,191	496	8.5	0.77	5,443
	Census Tract Total	4,191	496	8.5	0.77	5,443
FAIRFAX COUNTY		879,401	229,370	3.8	358.39	2,454

Note: The 1990 Census population for the City of Falls Church and the City of Fairfax is 9,578 and 19,622, respectively.

- 1/ Comprises part of the Town of Vienna (Vienna is composed of Census Tracts 607 through 610).
- 2/ Comprises part of the Town of Herndon (Herndon is composed of Census Tracts 808 and 809).
- 3/ Town of Clifton (Clifton is composed of Census Tract 909).

# IV. POPULATION FORECASTS

## POPULATION FORECASTS

Fairfax County's long-range forecasts of population are produced by the Fairfax County Office of Management and Budget. Periodically, the Fairfax County forecasts are developed in conjunction with forecasts of the surrounding jurisdictions under the auspices of the Washington Metropolitan Council of Governments (COG). The COG cooperative forecasts are generated every three to four years. The forecasts contained on the following tables are forecasts to be submitted for inclusion in the 1996 Round 5.3 COG regional forecast update.

### Methodology

The population forecasts by census and subcensus tract are calculated similarly to the current population estimates. The key factors are the number of housing units by type, the vacancy rates, and the average household sizes. Specifically, the forecasted number of housing units are multiplied by corresponding vacancy rates for the unit type and planning district. This generates the number of occupied housing units, or households. The households figure is then multiplied by the average household size (average number of persons per household) for the unit type and planning district to generate a household population figure. The housing unit forecasts are shown in Section VI of the 1995 Demographic Reports. To obtain the final population forecasts, the non-household, or group quarters, population is added to the household population.

The vacancy rates and household size factors were developed by the Fairfax County Office of Management and Budget. In effect, an overall vacancy rate of 3.4 percent (and thus, an occupancy rate of 96.6 percent) has been assumed for all forecast years in the County. This is based on trends in the overall occupancy rate, which has remained in the 95 to 97 percent range for the last 20 years.

An analysis of average household size, conducted by the Fairfax County Office of Management and Budget, has revealed three significant factors that will influence projected average household size: average household size differences by race; the increasingly diverse racial composition of Fairfax County; and the differences in average household size by unit type.

Between 1980 and 1990, the population of Fairfax County increased by 221,683 persons. Of this increase, nearly 46 percent of the persons added were non-white. It is important to note that the average household size for each non-white racial group is still higher than the current County-wide average household size (See Table 4.1). The addition of an increasing number of non-white households in the future, with above average household sizes, will have the effect of providing an upward pressure on Fairfax County's overall average household size as racial and ethnic minorities become a larger portion of the County's total population. This, offset by the long term trend toward smaller household size, will result in relatively stable average household sizes for Fairfax County through 2020. Additionally, the Office of Management and Budget has now forecasted the number of housing units in the County by housing unit type. This information, combined with forecasted average household sizes for each unit type provides a clearer indication of trends in the County's population. Forecasted average household size factors by planning district are presented in Table 4.2.

TABLE 4.1

Average Household Size by Race  
Fairfax County, 1980 and 1990

Racial or Ethnic Origin Group	Average Household Size	
	1980	1990
White	2.84	2.65
Black	2.99	2.86
Asian	2.74	3.69
Hispanic	3.34	3.66
<b>Fairfax County</b>	<b>2.88</b>	<b>2.75</b>

Source: U.S. Bureau of the Census.

TABLE 4.2  
Current and Forecasted Average Household Size  
By Planning District, 1995 - 2020

Planning District	Average Household Size					
	1995	2000	2005	2010	2015	2020
Annandale	2.70	2.71	2.70	2.70	2.69	2.68
Baileys	2.28	2.28	2.27	2.26	2.25	2.24
Bull Run	2.78	2.77	2.77	2.75	2.73	2.71
Fairfax	2.59	2.59	2.59	2.57	2.56	2.54
Jefferson	2.55	2.55	2.54	2.53	2.52	2.51
Lincolnia	2.44	2.43	2.42	2.40	2.38	2.37
Lower Potomac	2.62	2.61	2.62	2.62	2.63	2.64
McLean	2.68	2.68	2.66	2.64	2.61	2.58
Mount Vernon	2.42	2.42	2.43	2.42	2.41	2.40
Pohick	3.07	3.08	3.07	3.06	3.06	3.04
Rose Hill	2.47	2.46	2.45	2.43	2.42	2.40
Springfield	2.93	2.89	2.85	2.83	2.81	2.80
Upper Potomac	2.88	2.86	2.85	2.82	2.80	2.78
Vienna	2.72	2.72	2.71	2.69	2.67	2.65
<b>Fairfax County</b>	<b>2.71</b>	<b>2.71</b>	<b>2.70</b>	<b>2.69</b>	<b>2.67</b>	<b>2.65</b>

The population age distribution forecasts for all of Fairfax County were generated using a cohort survival methodology. Essentially, this methodology survives the existing population, forecasts births, and projects the extent and age distribution of in-migrants. The age forecasts methodology and assumptions were reviewed by the Age Forecasting Committee, comprised of representatives from selected County agencies.

Tables

The tables that follow show Fairfax County's population increasing from 455,021 in 1970 to 596,901 in 1980 and to 818,584 in 1990, based on 1970, 1980 and 1990 Census information, respectively. Between 1995 and 2000, the County's population is expected to increase by 63,932 persons, from an estimate of 879,401 in 1995 to 943,333 projected in 2000. By the year 2010, the County's population is projected to be 1,058,252, an increase of 178,851 persons over the County's 1995 population total, and by the year 2020 the County's population is projected to be 1,193,430.

Population forecasts have been prepared for each of the County's supervisor districts. It should be noted that supervisor district boundaries are constitutionally mandated to be reviewed (and possibly changed) every ten years. The forecasts contained in the following tables reflect the district boundaries as of July 1991.

The area comprising the Sully Supervisor District, which as of January 1995 had the largest population among the nine supervisor districts, is expected to remain the area of the County with the largest population through the year 2020. The Springfield District is currently the second largest supervisor district in terms of population. However, by the year 2000, it will fall to fifth place as the population of Lee, Hunter Mill and Dranesville Districts are expected to increase considerably. The Braddock Supervisor District's population is expected to increase moderately between 1995 and 2020, to a total of 102,675.

Figure 4.1

# Forecasted Population Growth 1995 to 2020

Fairfax County, Virginia

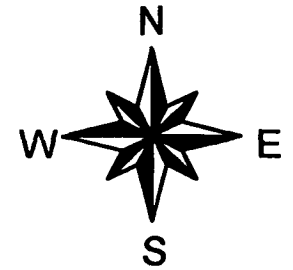
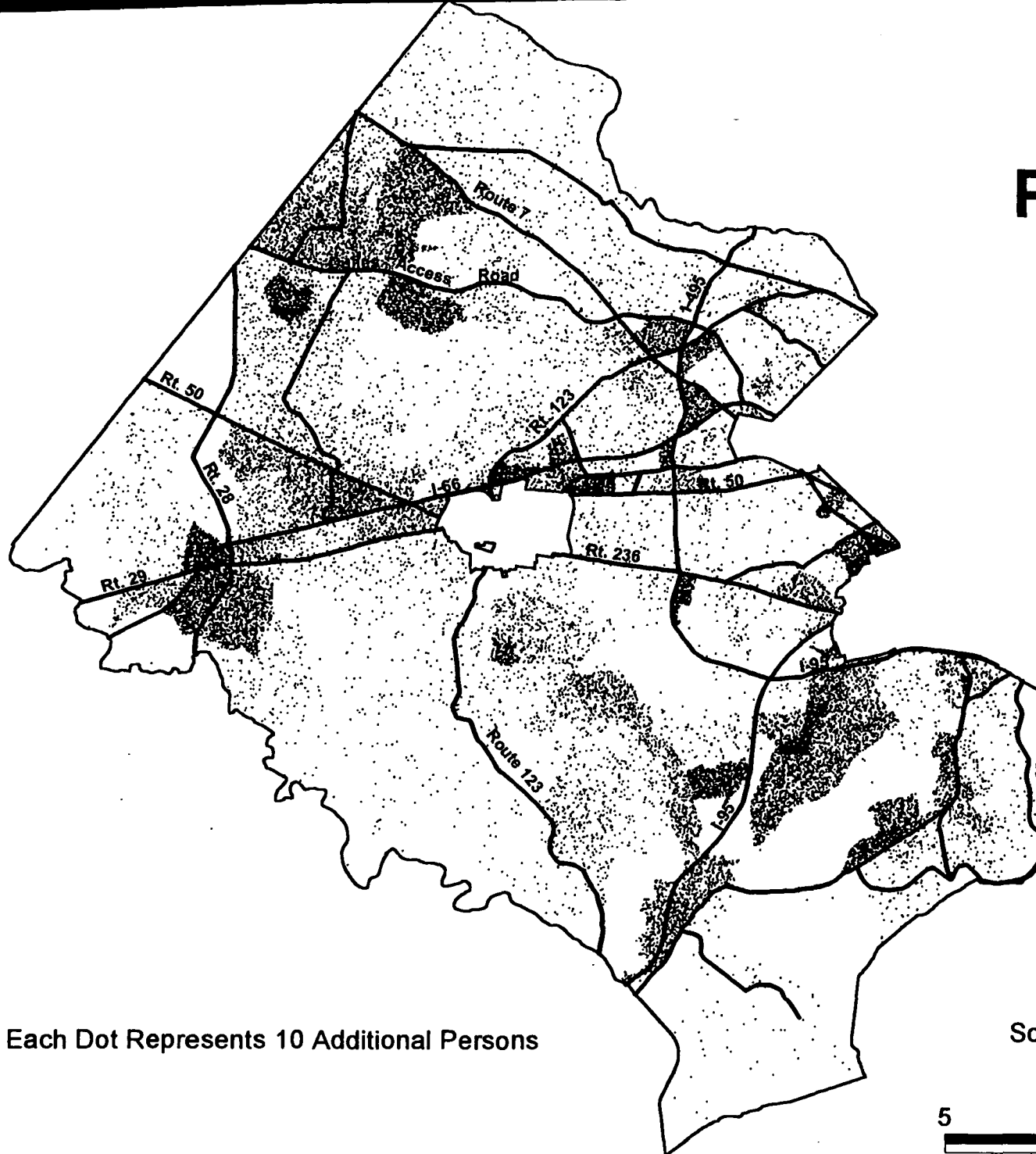

Each Dot Represents 10 Additional Persons

Source: Urban Development Information System,  
Office of Management and Budget.





Historical, Estimated and Forecasted Population  
Supervisor District  
(January 1995)

Supervisor District	1990	1995	2000	2005	2010	2015	2020
Braddock	90,767	89,824	90,215	93,549	96,385	99,344	102,675
Dranesville 1/	92,296	97,924	105,070	110,138	114,614	119,473	125,109
Hunter Mill 2/	90,714	97,934	108,995	117,014	125,732	135,346	146,868
Lee	90,049	93,513	108,608	119,314	130,412	142,109	154,515
Mason	90,725	89,855	91,693	95,066	98,742	102,785	107,586
Mount Vernon	87,124	96,114	100,549	104,642	108,654	112,966	118,001
Providence	90,778	95,314	100,446	107,026	114,397	122,590	132,460
Springfield 3/	92,626	98,607	103,156	107,148	110,623	114,253	118,339
Sully	93,505	120,316	134,599	146,564	158,694	172,005	187,877
Fairfax County	818,584	879,401	943,333	1,000,461	1,058,252	1,120,870	1,193,430

Historical, Estimated and Forecasted Population  
Towns  
(January 1995)

Town	1990	1995	2000	2005	2010	2015	2020
Town of Clifton	176	222	227	233	237	241	245
Town of Herndon	16,139	16,737	18,436	20,632	23,078	25,795	29,069
Town of Vienna	14,852	14,838	14,989	15,258	15,404	15,552	15,702
Towns Total	31,167	31,798	33,651	36,123	38,719	41,588	45,016

Sources: U.S. Bureau of the Census, U.S. Census of Population and Housing: 1990.  
Fairfax County Office of Management and Budget: 1995 through 2020.

- 1/ Includes the Town of Herndon.
- 2/ Includes the Town of Vienna.
- 3/ Includes the Town of Clifton.

Historical, Estimated and Forecasted Population  
 Planning District  
 (January 1995)

Planning District	1970	1980	1990	1995	2000	2005	2010	2015	2020
Annandale	62,635	66,466	66,329	67,635	68,068	69,418	70,701	72,068	73,626
Baileys	30,112	30,290	38,392	37,499	38,160	40,198	42,604	45,318	48,611
Bull Run	14,006	23,566	66,234	87,641	98,506	108,665	119,232	130,850	144,766
Fairfax	22,889	32,332	45,244	50,524	53,714	56,860	59,823	63,085	66,959
Jefferson	40,989	38,152	42,859	45,167	45,562	47,160	48,980	51,017	53,478
Lincolnia	11,123	9,978	14,010	13,388	14,147	15,001	15,934	16,931	18,094
Lower Potomac	21,497	16,305	24,371	25,830	28,210	29,995	32,135	34,496	37,356
McLean	46,866	54,669	58,747	62,566	66,446	68,862	71,154	73,683	76,667
Mount Vernon	76,730	79,533	82,483	85,539	87,206	91,900	96,284	101,069	106,718
Pohick 1/	14,902	71,543	127,040	132,049	137,459	143,353	148,553	153,939	159,970
Rose Hill	21,859	23,262	34,520	38,692	42,646	46,174	50,185	54,583	59,860
Springfield	32,970	31,667	39,919	43,240	54,018	58,620	63,058	67,382	70,892
Upper Potomac 2/	20,062	70,795	125,169	138,227	154,662	166,813	179,359	193,158	209,582
Vienna 3/	38,381	48,343	53,267	51,402	54,531	57,441	60,252	63,292	66,851
Fairfax County	455,021	596,901	818,584	879,401	943,333	1,000,461	1,058,252	1,120,870	1,193,430

Sources: U.S. Bureau of the Census, U.S. Census of Population and Housing: 1970, 1980, 1990;  
 Fairfax County Office of Management and Budget: 1995 through 2020.

- 1/ Includes the Town of Clifton.
- 2/ Includes the Town of Herndon.
- 3/ Includes the Town of Vienna.

Historical and Forecasted Population  
Census and Subcensus Tract  
(January 1995)

Census Tract	Subcensus Tract	1990	1995	2000	2005	2010	2015	2020
151	151.01		1,316	1,365	1,391	1,408	1,425	1,443
	151.02		1,330	1,326	1,376	1,384	1,393	1,401
	151.03		870	885	897	903	909	916
	Census Tract Total	3,262	3,516	3,575	3,664	3,696	3,727	3,760
152	152.01		879	922	933	939	946	952
	152.02		2,888	2,823	2,873	2,928	2,985	3,047
	152.03		332	332	332	332	332	333
	152.04							
	Census Tract Total	3,165	4,099	4,076	4,138	4,200	4,263	4,332
153	153.01		771	825	850	864	878	892
	153.02		1,509	1,520	1,525	1,527	1,530	1,533
	153.03		1,187	1,193	1,194	1,194	1,194	1,195
	153.04		284	284	284	284	284	284
	Census Tract Total	3,610	3,750	3,822	3,852	3,869	3,886	3,903
154	154.01		5,245	5,316	5,496	5,604	5,715	5,835
	154.02		1,154	1,160	1,180	1,191	1,202	1,213
	154.03		983	1,047	1,169	1,315	1,472	1,658
	Census Tract Total	7,163	7,382	7,523	7,845	8,110	8,389	8,707
155	155.01		2,912	2,937	3,219	3,533	3,876	4,289
	155.02		1,951	1,954	1,967	1,974	1,981	1,988
	155.03		837	845	857	864	870	877
	155.04		255	255	256	256	257	257
	Census Tract Total	5,644	5,955	5,991	6,300	6,627	6,985	7,411
156	156.01		1,554	1,565	1,577	1,583	1,589	1,595
	156.02		223	258	259	260	261	261
	156.03		829	872	899	914	929	944
	156.04		324	414	434	444	455	467
	Census Tract Total	2,438	2,931	3,110	3,169	3,201	3,234	3,267
157	157.01		1,225	1,268	1,277	1,282	1,287	1,291
	157.02		2,118	2,127	2,158	2,174	2,191	2,207
	157.03		546	549	550	551	552	552

(CONTINUED)

Historical and Forecasted Population  
Census and Subcensus Tract  
(January 1995)

Census Tract	Subcensus Tract	1990	1995	2000	2005	2010	2015	2020
157	Census Tract Total	3,606	3,890	3,944	3,985	4,007	4,029	4,051
158	158.01		1,894	1,917	1,999	2,043	2,089	2,135
	158.02		1,502	1,512	1,549	1,569	1,589	1,610
	158.03		1,309	1,319	1,372	1,401	1,431	1,461
	Census Tract Total	4,622	4,706	4,747	4,920	5,013	5,109	5,206
159	159.01		2,412	2,510	2,592	2,636	2,681	2,727
	159.02		535	596	611	619	627	635
	159.03							
	159.04		354	394	399	401	404	406
	Census Tract Total	3,094	3,302	3,500	3,601	3,656	3,711	3,768
160	160.01		631	670	728	788	856	939
	160.02		2,467	2,475	2,629	2,749	2,880	3,037
	160.03		839	854	866	873	879	886
	Census Tract Total	3,705	3,937	3,999	4,222	4,409	4,616	4,862
161	161.01		482	490	509	520	530	541
	161.02		274	275	276	277	278	278
	161.03		1,768	1,798	1,875	1,917	1,961	2,005
	161.04		1,307	1,364	1,429	1,464	1,500	1,537
	Census Tract Total	3,751	3,832	3,927	4,089	4,178	4,269	4,362
162	162.01		5,580	5,602	5,602	5,602	5,602	5,602
	162.02							
	Census Tract Total	5,621	5,580	5,602	5,602	5,602	5,602	5,602
163	163.01		669	852	891	913	935	958
	163.02		1,260	1,515	1,565	1,593	1,621	1,649
	Census Tract Total	1,778	1,929	2,367	2,457	2,506	2,556	2,607
201	201.01		1,401	1,401	1,402	1,402	1,402	1,403
	201.02		1,846	1,872	1,953	2,002	2,051	2,102
	Census Tract Total	3,098	3,247	3,273	3,354	3,404	3,454	3,505
202	202.01		2,947	3,908	4,566	5,335	6,181	7,203
	202.02		2,154	2,370	2,620	2,897	3,201	3,565
	Census Tract Total	5,113	5,101	6,278	7,186	8,232	9,382	10,768

(CONTINUED)

Historical and Forecasted Population  
Census and Subcensus Tract  
(January 1995)

Census Tract	Subcensus Tract	1990	1995	2000	2005	2010	2015	2020
203	203.01		1,755	1,775	1,806	1,823	1,839	1,856
	203.02		1,684	1,690	1,722	1,740	1,758	1,776
	203.03		666	810	845	889	938	997
	203.04		752	1,007	1,138	1,282	1,439	1,628
	Census Tract Total	4,903	4,857	5,281	5,512	5,734	5,974	6,257
204	204.01		3,090	3,125	3,180	3,239	3,296	3,357
	Census Tract Total	2,368	3,090	3,125	3,180	3,239	3,296	3,357
205	205.01		6,176	6,139	6,301	6,483	6,668	6,874
	205.02		504	504	505	506	507	507
	Census Tract Total	5,121	6,680	6,643	6,807	6,989	7,175	7,381
206	206.01		449	455	455	455	455	455
	206.02		961	1,052	1,217	1,412	1,616	1,852
	206.03		2,361	2,414	2,501	2,581	2,663	2,752
	Census Tract Total	4,049	3,770	3,921	4,173	4,448	4,734	5,060
207	207.01		1,720	1,819	1,847	1,862	1,877	1,892
	207.02		355	366	378	384	390	397
	207.03		1,508	1,541	1,576	1,595	1,613	1,632
	Census Tract Total	3,833	3,583	3,726	3,801	3,840	3,880	3,921
208	208.01		922	952	969	978	987	997
	208.02		729	729	739	744	749	754
	208.03		1,482	1,488	1,535	1,560	1,586	1,613
	Census Tract Total	3,295	3,134	3,170	3,243	3,283	3,323	3,364
210	210.01		900	1,802	2,061	2,353	2,673	3,059
	210.02		1,636	1,832	2,213	2,684	3,204	3,836
	210.03		730	4,123	4,566	5,023	5,522	6,113
	210.04		922	922	923	923	924	924
	Census Tract Total	3,657	4,188	8,679	9,763	10,983	12,323	13,932
211	211.01		5,564	7,837	8,954	10,211	11,581	13,216
	211.02		3,232	4,537	5,172	5,928	6,762	7,770
	211.03		482	482	483	484	485	486
	Census Tract Total	6,597	9,278	12,855	14,609	16,623	18,827	21,471

(CONTINUED)

Historical and Forecasted Population  
Census and Subcensus Tract  
(January 1995)

Census Tract	Subcensus Tract	1990	1995	2000	2005	2010	2015	2020
212	212.01		1,901	1,902	1,903	1,904	1,905	1,906
	Census Tract Total	2,181	1,901	1,902	1,903	1,904	1,905	1,906
213	213.01		3,461	3,497	3,517	3,536	3,553	3,571
	213.02		250	250	250	250	250	250
	Census Tract Total	3,950	3,712	3,747	3,768	3,787	3,804	3,821
214	214.01		1,915	1,937	1,940	1,942	1,944	1,946
	214.02		3,073	3,134	3,444	3,823	4,254	4,780
	Census Tract Total	5,178	4,988	5,071	5,385	5,766	6,198	6,726
215	215.01		4,473	4,697	5,471	5,861	6,300	6,823
	Census Tract Total	5,007	4,473	4,697	5,471	5,861	6,300	6,823
216	216.01		3,221	3,228	3,228	3,228	3,228	3,228
	216.02		1,133	1,141	1,250	1,382	1,525	1,695
	Census Tract Total	4,982	4,354	4,369	4,478	4,610	4,753	4,923
217	217.01		6,507	6,620	7,359	8,264	9,270	10,493
	Census Tract Total	7,425	6,507	6,620	7,359	8,264	9,270	10,493
218	218.01		4,378	4,546	5,262	6,140	7,125	8,328
	Census Tract Total	4,528	4,378	4,546	5,262	6,140	7,125	8,328
219	219.01		1,143	1,143	1,143	1,143	1,143	1,143
	Census Tract Total	2,969	1,143	1,143	1,143	1,143	1,143	1,143
220	220.01		3	3	3	3	3	3
	220.02							
	220.03		1,288	1,624	1,833	2,088	2,367	2,703
	220.04		27	27	27	27	27	27
	220.05		414	438	438	438	438	438
	Census Tract Total	2,239	1,732	2,092	2,301	2,556	2,835	3,172
221	221.01		3,930	4,061	4,463	4,956	5,499	6,160
	221.02		3	3	3	3	3	3
	221.03		1,051	2,277	2,716	3,259	3,863	4,600
	221.04		2,486	2,658	3,268	4,026	4,863	5,881
	221.05		596	627	661	702	747	803
	221.06		102	102	104	106	107	108

(CONTINUED)

Historical and Forecasted Population  
Census and Subcensus Tract  
(January 1995)

Census Tract	Subcensus Tract	1990	1995	2000	2005	2010	2015	2020
221	Census Tract Total	6,274	8,168	9,728	11,215	13,051	15,083	17,554
222	222.01		7,281	7,281	7,281	7,281	7,281	7,281
	Census Tract Total	5,548	7,281	7,281	7,281	7,281	7,281	7,281
223	223.01		5,141	5,727	6,319	7,007	7,759	8,656
	Census Tract Total	3,844	5,141	5,727	6,319	7,007	7,759	8,656
224	224.01		6,825	7,072	8,053	9,248	10,567	12,166
	224.02		1,208	1,208	1,217	1,222	1,226	1,231
	Census Tract Total	5,838	8,032	8,279	9,270	10,470	11,793	13,397
301	301.01		1,528	1,538	1,559	1,570	1,581	1,592
	301.02		3,470	3,470	3,560	3,609	3,658	3,707
	301.03		2,796	2,803	3,247	3,780	4,367	5,078
	Census Tract Total	7,794	7,794	7,811	8,366	8,958	9,606	10,378
302	302.01		11,984	12,037	12,796	13,424	14,048	14,715
	Census Tract Total	12,357	11,984	12,037	12,796	13,424	14,048	14,715
304	304.01		4,106	4,107	4,108	4,109	4,110	4,110
	304.02		2,473	2,473	2,473	2,473	2,473	2,473
	Census Tract Total	6,727	6,579	6,580	6,581	6,582	6,583	6,584
305	305.01		1,640	1,646	1,653	1,656	1,660	1,664
	Census Tract Total	1,681	1,640	1,646	1,653	1,656	1,660	1,664
306	306.01		1,525	1,522	1,537	1,552	1,568	1,584
	306.02		1,125	1,125	1,125	1,125	1,126	1,126
	306.03		1,313	1,308	1,309	1,309	1,309	1,309
	306.04		1,397	1,398	1,399	1,400	1,400	1,401
	Census Tract Total	5,282	5,359	5,353	5,370	5,386	5,403	5,420
307	307.01		697	697	698	698	699	699
	307.02		1,086	1,086	1,087	1,087	1,087	1,087
	307.03		1,198	1,199	1,202	1,203	1,205	1,206
	Census Tract Total	2,412	2,981	2,982	2,986	2,988	2,990	2,992
308	308.01		8,957	8,992	8,995	8,997	8,999	9,001
	Census Tract Total	8,372	8,957	8,992	8,995	8,997	8,999	9,001
309	309.01		6,306	6,632	7,397	8,218	9,090	10,103

(CONTINUED)

Historical and Forecasted Population  
Census and Subcensus Tract  
(January 1995)

Census Tract	Subcensus Tract	1990	1995	2000	2005	2010	2015	2020
309	Census Tract Total	6,478	6,306	6,632	7,397	8,218	9,090	10,103
310	310.01		6,595	6,637	7,011	7,393	7,761	8,154
	Census Tract Total	6,813	6,595	6,637	7,011	7,393	7,761	8,154
313	313.01		4,378	4,383	4,456	4,495	4,535	4,575
	Census Tract Total	4,353	4,378	4,383	4,456	4,495	4,535	4,575
314	314.01		3,928	3,932	4,271	4,678	5,124	5,661
	Census Tract Total	4,048	3,928	3,932	4,271	4,678	5,124	5,661
315	315.01		5,773	5,795	5,897	5,975	6,049	6,125
	Census Tract Total	5,091	5,773	5,795	5,897	5,975	6,049	6,125
316	316.01		2,138	2,204	2,287	2,347	2,407	2,470
	316.02		2,493	2,520	2,575	2,619	2,661	2,706
	316.03		10	3,856	5,892	7,589	8,946	8,946
	Census Tract Total	4,407	4,641	8,579	10,754	12,555	14,015	14,121
318	318.01		6,934	6,961	7,278	7,572	7,851	8,142
	Census Tract Total	7,397	6,934	6,961	7,278	7,572	7,851	8,142
319	319.01		3,446	3,460	3,468	3,473	3,478	3,482
	Census Tract Total	3,743	3,446	3,460	3,468	3,473	3,478	3,482
320	320.01		3,232	3,240	3,260	3,278	3,295	3,312
	Census Tract Total	3,601	3,232	3,240	3,260	3,278	3,295	3,312
321	321.01		3,725	3,717	3,771	3,820	3,865	3,912
	Census Tract Total	3,797	3,725	3,717	3,771	3,820	3,865	3,912
322	322.01		6,677	6,695	6,821	6,935	7,040	7,148
	Census Tract Total	6,574	6,677	6,695	6,821	6,935	7,040	7,148
323	323.01		3,387	3,402	3,405	3,406	3,408	3,409
	323.02		1,372	1,592	1,635	1,658	1,681	1,705
	Census Tract Total	4,719	4,760	4,994	5,040	5,064	5,089	5,114
324	324.01		8,303	8,306	8,476	8,584	8,688	8,795
	Census Tract Total	9,301	8,303	8,306	8,476	8,584	8,688	8,795
325	325.01		5,706	5,786	5,976	6,080	6,186	6,294
	Census Tract Total	5,607	5,706	5,786	5,976	6,080	6,186	6,294
326	326.01		4,683	4,693	4,866	4,961	5,058	5,157

(CONTINUED)



Historical and Forecasted Population  
Census and Subcensus Tract  
(January 1995)

Census Tract	Subcensus Tract	1990	1995	2000	2005	2010	2015	2020
326	Census Tract Total	4,580	4,683	4,693	4,866	4,961	5,058	5,157
327	327.01		7,339	7,534	8,244	9,047	9,912	10,936
	Census Tract Total	7,456	7,339	7,534	8,244	9,047	9,912	10,936
328	328.01		2,045	2,042	2,060	2,070	2,080	2,090
	Census Tract Total	2,277	2,045	2,042	2,060	2,070	2,080	2,090
401	401.01		1,812	1,813	1,835	1,846	1,858	1,870
	401.02		3,068	3,078	3,216	3,292	3,370	3,450
	401.03		2,441	2,520	2,543	2,555	2,567	2,579
	Census Tract Total	6,804	7,322	7,411	7,594	7,693	7,795	7,899
402	402.01		614	617	703	809	932	1,084
	402.02		4,650	4,652	4,705	4,751	4,796	4,841
	402.03			25	25	25	25	25
	402.04		394	415	427	433	439	446
	Census Tract Total	5,692	5,658	5,710	5,859	6,019	6,192	6,397
403	403.01		1,362	1,380	1,397	1,407	1,416	1,425
	403.02		1,292	1,299	1,333	1,352	1,371	1,390
	Census Tract Total	2,880	2,654	2,678	2,731	2,759	2,787	2,816
405	405.01		3,049	3,065	3,066	3,067	3,067	3,068
	405.02		1,305	1,327	1,347	1,358	1,369	1,380
	405.03		4,718	4,747	4,956	5,070	5,187	5,307
	405.04		1,084	1,084	1,084	1,084	1,084	1,084
	Census Tract Total	10,289	10,155	10,223	10,453	10,579	10,707	10,838
406	406.01		2,549	2,588	2,981	3,053	3,127	3,203
	Census Tract Total	2,723	2,549	2,588	2,981	3,053	3,127	3,203
407	407.01		5,139	5,148	5,169	5,180	5,191	5,202
	407.02		2,864	2,902	2,935	2,953	2,971	2,989
	Census Tract Total	8,313	8,003	8,050	8,104	8,133	8,162	8,191
408	408.01		2,392	2,394	2,400	2,403	2,406	2,409
	408.02		281	286	287	287	288	288
	408.03		1,263	1,284	1,302	1,312	1,321	1,331
	408.04		1,932	1,996	2,090	2,142	2,195	2,249

(CONTINUED)

Historical and Forecasted Population  
Census and Subcensus Tract  
(January 1995)

Census Tract	Subcensus Tract	1990	1995	2000	2005	2010	2015	2020
408	408.05							
	Census Tract Total	5,583	5,867	5,961	6,079	6,144	6,210	6,277
501	501.01		3,279	3,287	3,504	3,773	4,071	4,432
	501.02		875	875	876	876	876	877
	501.03		1,106	1,106	1,109	1,111	1,112	1,114
	Census Tract Total	4,361	5,260	5,268	5,489	5,760	6,059	6,422
502	502.01		1,312	1,310	1,310	1,310	1,310	1,310
	502.02		675	676	676	677	677	677
	502.03		469	480	485	488	490	493
	502.04		1,091	1,091	1,101	1,107	1,113	1,118
	Census Tract Total	4,219	3,547	3,557	3,573	3,581	3,590	3,598
503	503.01		846	849	853	856	858	861
	503.02		818	818	818	819	819	819
	503.03		1,944	1,997	2,013	2,022	2,032	2,041
	503.04		631	684	694	700	705	710
	Census Tract Total	4,300	4,239	4,349	4,379	4,396	4,414	4,431
504	504.01		1,011	1,022	1,039	1,051	1,063	1,076
	504.02		940	940	944	945	947	949
	504.03		637	651	659	664	668	673
	Census Tract Total	2,545	2,589	2,614	2,642	2,661	2,679	2,697
505	505.01		1,001	1,002	1,003	1,003	1,003	1,004
	505.02		843	843	846	847	849	850
	505.03		623	640	642	642	643	644
	Census Tract Total	2,628	2,467	2,485	2,490	2,493	2,496	2,499
506	506.01		531	531	548	557	565	575
	506.02		3,793	3,828	3,888	3,954	4,020	4,091
	506.03		829	829	831	832	833	834
	506.04		528	528	528	528	528	528
	506.05		715	743	749	753	756	759
	506.06		1,043	1,043	1,048	1,051	1,054	1,056
	506.07		483	486	490	491	493	495

(CONTINUED)

Historical and Forecasted Population  
Census and Subcensus Tract  
(January 1995)

Census Tract	Subcensus Tract	1990	1995	2000	2005	2010	2015	2020
506	Census Tract Total	7,876	7,923	7,990	8,083	8,165	8,249	8,339
507	507.01		2,601	2,630	2,664	2,682	2,700	2,718
	507.02		3,352	3,428	3,449	3,461	3,472	3,484
	Census Tract Total	6,218	5,952	6,058	6,113	6,142	6,172	6,202
508	508.01		850	850	860	866	871	877
	508.02		1,303	1,310	1,316	1,320	1,323	1,326
	508.03		1,058	1,056	1,064	1,068	1,072	1,076
	Census Tract Total	2,994	3,212	3,217	3,240	3,253	3,266	3,278
509	509.01		796	796	805	809	814	819
	509.02		824	824	827	829	831	833
	Census Tract Total	1,607	1,619	1,619	1,632	1,638	1,645	1,651
510	510.01		1,186	1,189	1,189	1,189	1,190	1,190
	510.02		1,627	1,634	1,643	1,648	1,653	1,657
	Census Tract Total	2,749	2,813	2,822	2,832	2,837	2,842	2,847
511	511.01		958	972	972	972	973	973
	511.02		1,200	1,209	1,212	1,214	1,216	1,218
	Census Tract Total	2,250	2,158	2,180	2,184	2,186	2,189	2,191
512	512.01		602	602	603	604	604	605
	512.02		820	823	825	826	827	828
	512.03		264	264	267	269	270	272
	Census Tract Total	1,702	1,685	1,688	1,694	1,698	1,701	1,705
513	513.01		1,139	1,192	1,226	1,244	1,262	1,281
	513.02		1,109	1,115	1,118	1,119	1,120	1,121
	Census Tract Total	2,044	2,248	2,307	2,343	2,363	2,382	2,402
514	514.01		414	406	406	406	406	406
	514.02		1,428	1,441	1,441	1,441	1,441	1,441
	514.03		679	684	691	699	705	712
	Census Tract Total	2,721	2,522	2,531	2,538	2,545	2,552	2,559
515	515.01		2,006	1,998	1,998	1,998	1,999	1,999
	515.02		2,824	2,840	3,088	3,387	3,730	4,153
	515.03		1,736	1,765	1,786	1,803	1,819	1,835

(CONTINUED)

Historical and Forecasted Population  
Census and Subcensus Tract  
(January 1995)

Census Tract	Subcensus Tract	1990	1995	2000	2005	2010	2015	2020
515	515.04		1,986	2,018	2,093	2,178	2,267	2,367
	Census Tract Total	8,412	8,552	8,621	8,966	9,367	9,815	10,353
516	516.01		1,678	1,761	1,970	2,226	2,512	2,858
	516.02		213	213	213	213	213	213
	516.03		1,661	1,650	1,650	1,650	1,650	1,650
	516.04		1,316	1,363	1,366	1,368	1,370	1,372
	516.05		958	968	971	972	974	975
	Census Tract Total	7,647	5,827	5,954	6,170	6,429	6,719	7,068
518	518.01		1,221	1,226	1,230	1,232	1,234	1,236
	518.02		461	482	489	493	497	501
	518.03		1,132	1,153	1,170	1,180	1,189	1,198
	Census Tract Total	2,919	2,814	2,861	2,890	2,905	2,920	2,936
519	519.01		4,994	5,071	5,677	6,355	7,079	7,923
	Census Tract Total	5,187	4,994	5,071	5,677	6,355	7,079	7,923
520	520.01		2,926	2,957	3,012	3,041	3,071	3,102
	Census Tract Total	2,550	2,926	2,957	3,012	3,041	3,071	3,102
521	521.01		344	347	348	349	349	350
	521.02		2,520	2,533	2,599	2,660	2,718	2,780
	521.03		1,477	1,481	1,518	1,548	1,576	1,605
	521.04		1,647	1,683	1,692	1,697	1,702	1,707
	521.05		1,060	1,069	1,089	1,104	1,119	1,134
	Census Tract Total	6,592	7,048	7,114	7,246	7,358	7,465	7,575
522	522.01		3,417	3,422	3,424	3,425	3,426	3,427
	522.02		1,107	1,108	1,111	1,113	1,114	1,116
	522.03		1,018	1,018	1,019	1,019	1,020	1,020
	Census Tract Total	5,323	5,542	5,548	5,554	5,557	5,560	5,564
523	523.01		7,104	7,060	7,814	8,717	9,708	10,882
	Census Tract Total	6,399	7,104	7,060	7,814	8,717	9,708	10,882
524	524.01		1,466	1,466	1,467	1,467	1,467	1,468
	524.02		998	998	998	998	998	998
	524.03		821	839	841	842	843	844

(CONTINUED)

Historical and Forecasted Population  
Census and Subcensus Tract  
(January 1995)

Census Tract	Subcensus Tract	1990	1995	2000	2005	2010	2015	2020
524	524.04		1,849	1,857	1,860	1,862	1,864	1,866
	524.05		1,216	1,260	1,309	1,354	1,396	1,440
	Census Tract Total	6,051	6,351	6,420	6,475	6,523	6,569	6,616
525	525.01		827	827	827	827	827	827
	525.02		1,116	1,130	1,157	1,171	1,186	1,201
	525.03		951	962	972	977	982	987
	525.04		3,837	4,150	4,228	4,287	4,346	4,407
	Census Tract Total	6,792	6,730	7,069	7,184	7,262	7,341	7,422
526	526.01		1,944	1,989	1,998	2,002	2,007	2,011
	526.02		1,075	1,085	1,085	1,086	1,086	1,086
	526.03		588	890	1,041	1,227	1,432	1,680
	Census Tract Total	3,888	3,607	3,964	4,124	4,315	4,524	4,778
527	527.01		3,720	3,990	4,403	4,887	5,416	6,045
	Census Tract Total	4,239	3,720	3,990	4,403	4,887	5,416	6,045
528	528.01		7,974	8,028	9,010	10,224	11,623	13,353
	Census Tract Total	6,456	7,974	8,028	9,010	10,224	11,623	13,353
530	Census Tract Total	3						
531	Census Tract Total	2						
601	601.01		1,006	1,017	1,030	1,037	1,044	1,052
	601.02		1,962	1,983	2,036	2,065	2,094	2,123
	601.03		775	817	856	877	898	921
	Census Tract Total	3,777	3,744	3,817	3,922	3,979	4,036	4,095
602	602.01		1,380	1,548	1,599	1,627	1,655	1,684
	602.02		175	209	215	218	222	225
	602.03		1,818	1,819	1,852	1,869	1,886	1,904
	Census Tract Total	3,874	3,374	3,576	3,666	3,715	3,764	3,814
603	603.01		681	723	757	776	795	815
	603.02		1,864	1,884	1,959	2,001	2,042	2,085
	Census Tract Total	2,761	2,545	2,607	2,717	2,777	2,838	2,900
604	604.01		664	740	768	783	799	815
	604.02		2,566	2,840	3,021	3,230	3,460	3,738

(CONTINUED)

Historical and Forecasted Population  
Census and Subcensus Tract  
(January 1995)

Census Tract	Subcensus Tract	1990	1995	2000	2005	2010	2015	2020
604	604.03		427	446	457	462	468	474
	Census Tract Total	3,210	3,656	4,026	4,246	4,476	4,727	5,026
605	605.01		1,761	2,340	2,520	2,679	2,850	3,047
	605.02		1,630	1,745	1,805	1,847	1,887	1,929
	605.03		838	889	903	911	919	927
	605.04		489	511	519	526	532	539
	605.05		1,359	1,475	1,511	1,534	1,556	1,580
	Census Tract Total	5,655	6,077	6,961	7,258	7,496	7,744	8,021
606	606.01		415	421	426	429	432	435
	606.02		3,232	3,323	3,426	3,482	3,539	3,597
	Census Tract Total	3,709	3,647	3,744	3,853	3,912	3,972	4,032
607 /1	607.01		7,225	7,253	7,432	7,530	7,630	7,731
	Census Tract Total	7,475	7,225	7,253	7,432	7,530	7,630	7,731
608 /1	608.01		2,974	3,061	3,090	3,105	3,120	3,136
	Census Tract Total	2,765	2,974	3,061	3,090	3,105	3,120	3,136
609 /1	609.01		2,366	2,397	2,431	2,450	2,468	2,486
	Census Tract Total	2,362	2,366	2,397	2,431	2,450	2,468	2,486
610 /1	610.01		2,274	2,277	2,305	2,320	2,334	2,349
	Census Tract Total	2,250	2,274	2,277	2,305	2,320	2,334	2,349
611	611.01		1,807	1,822	1,879	1,909	1,940	1,972
	611.02		4,456	4,780	4,972	5,112	5,254	5,407
	Census Tract Total	6,573	6,263	6,602	6,850	7,021	7,195	7,379
612	612.01		584	680	693	699	706	713
	612.02		3,016	3,586	3,736	3,818	3,902	3,988
	612.03		210	214	219	222	225	228
	612.04		30	640	755	898	1,058	1,254
	Census Tract Total	3,365	3,839	5,120	5,403	5,638	5,892	6,183
615	615.01		706	928	969	992	1,016	1,040
	615.02		761	763	772	778	783	788
	615.03		1,069	1,157	1,188	1,218	1,246	1,275
	615.04		1,330	1,503	1,854	2,290	2,771	3,357

(CONTINUED)

Historical and Forecasted Population  
Census and Subcensus Tract  
(January 1995)

Census Tract	Subcensus Tract	1990	1995	2000	2005	2010	2015	2020
615	615.05		251	251	251	251	251	251
	Census Tract Total	3,540	4,117	4,602	5,035	5,529	6,067	6,711
616	616.01		1,511	1,511	1,796	2,145	2,530	2,997
	616.02		966	991	1,032	1,058	1,084	1,110
	616.04		1,644	1,643	1,869	2,151	2,476	2,879
	616.05		799	802	834	866	896	927
	616.06		6	6	6	6	6	6
	Census Tract Total	4,979	4,926	4,953	5,536	6,225	6,991	7,919
617	617.01		3,867	4,550	5,349	6,318	7,399	8,718
	617.02		446	497	518	530	541	553
	Census Tract Total	4,555	4,313	5,047	5,867	6,847	7,941	9,271
618	618.01		820	816	905	1,015	1,141	1,296
	618.02		4,636	4,656	5,583	6,736	8,026	9,603
	Census Tract Total	5,054	5,456	5,472	6,488	7,751	9,167	10,899
619	619.02		4,085	4,080	4,242	4,438	4,659	4,924
	Census Tract Total	4,454	4,085	4,080	4,242	4,438	4,659	4,924
701	701.01		838	877	882	887	891	895
	701.02		1,333	1,416	1,441	1,454	1,467	1,480
	701.03		176	191	195	197	199	201
	701.04		481	553	571	582	592	603
	Census Tract Total	2,860	2,828	3,037	3,089	3,119	3,149	3,179
702	702.01		6	6	6	6	6	6
	Census Tract Total	60	6	6	6	6	6	6
703	703.01		1,987	2,036	2,066	2,082	2,098	2,114
	703.02		377	417	423	425	428	431
	703.03		892	984	1,009	1,023	1,037	1,051
	Census Tract Total	2,917	3,256	3,438	3,498	3,530	3,563	3,596
704	704.01		1,410	1,470	1,514	1,539	1,564	1,589
	704.02		128	134	135	135	135	136
	704.03		1,062	1,082	1,133	1,162	1,190	1,220
	704.04		769	775	793	802	811	821

(CONTINUED)

Historical and Forecasted Population  
Census and Subcensus Tract  
(January 1995)

Census Tract	Subcensus Tract	1990	1995	2000	2005	2010	2015	2020
704	704.05		1,485	1,485	1,525	1,547	1,570	1,592
	Census Tract Total	4,625	4,855	4,947	5,101	5,185	5,270	5,357
705	705.01		328	328	333	336	339	342
	705.02		981	981	983	984	985	986
	705.03		1,941	2,097	2,170	2,216	2,261	2,307
	705.04		875	906	911	913	916	918
	705.05		468	555	576	588	600	613
	705.06		802	799	909	1,046	1,205	1,402
	Census Tract Total	5,087	5,395	5,666	5,883	6,084	6,307	6,569
706	706.01		534	665	690	704	718	733
	706.02		494	494	500	503	506	510
	706.03		1,005	1,009	1,012	1,014	1,016	1,018
	706.04		501	528	533	537	540	544
	Census Tract Total	2,258	2,534	2,696	2,736	2,758	2,781	2,805
707	707.01		845	887	894	899	904	909
	707.02		1,184	1,205	1,231	1,245	1,259	1,273
	707.03		834	867	884	892	901	910
	707.04		1,127	1,127	1,128	1,129	1,129	1,130
	707.05		584	719	732	740	747	755
	707.06		766	772	773	773	774	774
	Census Tract Total	4,879	5,341	5,577	5,642	5,678	5,714	5,750
708	708.01		788	793	796	798	799	801
	708.02		2,222	2,228	2,236	2,240	2,244	2,248
	Census Tract Total	2,964	3,010	3,021	3,032	3,037	3,043	3,048
709	709.01		1,933	2,049	2,095	2,120	2,146	2,171
	709.02		2,095	2,123	2,177	2,224	2,269	2,315
	709.03		760	769	771	773	774	775
	709.04		815	816	967	1,149	1,350	1,593
	709.05		1,017	1,023	1,041	1,051	1,061	1,071
	709.06		313	316	317	317	318	318
	Census Tract Total	6,058	6,933	7,097	7,369	7,634	7,916	8,243

(CONTINUED)



Historical and Forecasted Population  
Census and Subcensus Tract  
(January 1995)

Census Tract	Subcensus Tract	1990	1995	2000	2005	2010	2015	2020
710	710.01		172	173	175	176	177	178
	710.02		656	659	667	672	676	680
	710.03		718	979	1,014	1,054	1,099	1,155
	Census Tract Total	1,239	1,545	1,811	1,856	1,901	1,952	2,013
711	711.01		508	508	508	508	508	508
	711.02		614	614	614	614	614	614
	711.03		796	799	803	805	807	810
	711.04		912	915	917	917	918	918
	711.05		731	731	731	731	732	732
	711.06		1,530	1,536	1,536	1,536	1,536	1,536
	711.07		567	567	568	569	569	570
	711.08		1,094	1,097	1,126	1,142	1,158	1,174
	Census Tract Total	6,447	6,752	6,767	6,803	6,823	6,842	6,862
712	712.01		3	3	3	3	3	3
	712.02							
	712.03		547	589	590	591	592	593
	712.04		4,756	4,832	5,365	6,028	6,792	7,738
	Census Tract Total	5,215	5,307	5,424	5,958	6,622	7,387	8,334
713	713.01		7,310	7,346	8,048	8,915	9,914	11,148
	713.02		1,667	1,684	1,701	1,711	1,721	1,730
	Census Tract Total	8,394	8,977	9,029	9,749	10,626	11,634	12,879
714	714.01		4,256	4,322	4,481	4,626	4,769	4,922
	714.02		2,026	2,038	2,041	2,043	2,044	2,046
	Census Tract Total	6,307	6,283	6,361	6,522	6,669	6,813	6,968
801	801.01		1,171	1,481	1,540	1,573	1,606	1,639
	801.02		680	702	720	730	740	749
	801.03		652	835	874	895	917	940
	801.04		814	941	982	1,005	1,028	1,051
	801.05		605	656	669	677	684	691
	Census Tract Total	3,374	3,922	4,616	4,786	4,879	4,974	5,071
802	802.01		939	1,047	1,096	1,123	1,151	1,179

(CONTINUED)

Historical and Forecasted Population  
Census and Subcensus Tract  
(January 1995)

Census Tract	Subcensus Tract	1990	1995	2000	2005	2010	2015	2020
802	802.02		1,336	1,386	1,418	1,435	1,452	1,469
	802.03		1,527	1,550	1,597	1,623	1,648	1,674
	802.04		3,445	4,767	5,312	5,991	6,754	7,689
	802.05			30	30	30	30	30
	Census Tract Total	6,580	7,247	8,781	9,453	10,201	11,035	12,042
803	803.01		2,684	2,947	3,082	3,157	3,233	3,311
	803.02		745	745	755	760	765	770
	803.03		2,460	2,960	3,088	3,158	3,229	3,303
	803.04		3	3	3	3	3	3
	Census Tract Total	5,669	5,893	6,655	6,928	7,077	7,230	7,387
804	804.01		1,854	2,074	2,169	2,221	2,274	2,328
	804.02		1,983	2,385	2,489	2,545	2,603	2,663
	804.03		1,157	1,218	1,243	1,257	1,271	1,285
	804.04		1,141	1,365	1,414	1,440	1,467	1,495
	804.05		2,423	2,560	2,678	2,743	2,809	2,877
	Census Tract Total	7,290	8,558	9,603	9,993	10,206	10,425	10,648
805	805.01		5,307	5,803	6,077	6,227	6,381	6,539
	805.02		5,310	5,578	5,947	6,243	6,560	6,920
	805.03		5,327	6,440	7,417	8,557	9,812	11,327
	Census Tract Total	14,925	15,944	17,821	19,440	21,027	22,753	24,786
808 /2	808.01		6,805	7,668	8,598	9,626	10,761	12,120
	Census Tract Total	6,665	6,805	7,668	8,598	9,626	10,761	12,120
809 /2	809.01		9,932	10,768	12,034	13,452	15,035	16,949
	Census Tract Total	9,478	9,932	10,768	12,034	13,452	15,035	16,949
810	810.01		2,655	2,947	3,168	3,435	3,730	4,087
	Census Tract Total	2,917	2,655	2,947	3,168	3,435	3,730	4,087
811	811.01		94	374	442	527	620	733
	811.02		2,231	5,473	6,480	7,700	9,056	10,706
	811.03		3,330	3,986	4,172	4,274	4,379	4,487
	811.04		3,979	4,077	4,269	4,375	4,483	4,594
	Census Tract Total	7,846	9,634	13,910	15,363	16,876	18,539	20,520

(CONTINUED)

Historical and Forecasted Population  
Census and Subcensus Tract  
(January 1995)

Census Tract	Subcensus Tract	1990	1995	2000	2005	2010	2015	2020
812	812.01		6,078	6,278	6,500	6,660	6,819	6,986
	Census Tract Total	6,571	6,078	6,278	6,500	6,660	6,819	6,986
814	814.01		7,236	7,242	7,261	7,271	7,281	7,292
	Census Tract Total	6,861	7,236	7,242	7,261	7,271	7,281	7,292
815	815.01		2,395	2,432	2,469	2,488	2,508	2,528
	Census Tract Total	2,296	2,395	2,432	2,469	2,488	2,508	2,528
816	816.01		1,452	1,519	1,542	1,555	1,567	1,580
	816.02		1,675	1,703	1,719	1,728	1,737	1,746
	Census Tract Total	3,002	3,127	3,222	3,262	3,283	3,304	3,326
817	817.01		1,717	1,757	1,817	1,849	1,881	1,914
	817.02		1,701	2,172	2,274	2,331	2,388	2,447
	817.03		1,852	1,877	1,911	1,929	1,947	1,965
	817.04		3,886	4,132	4,402	4,725	5,082	5,515
	Census Tract Total	7,377	9,155	9,938	10,403	10,833	11,299	11,841
819	819.01		3,284	3,549	3,583	3,601	3,620	3,639
	819.02		1,444	1,911	1,992	2,037	2,082	2,128
	Census Tract Total	4,902	4,727	5,461	5,575	5,638	5,702	5,767
820	820.01		5,309	7,303	8,385	9,634	11,010	12,668
	820.02		1,297	1,297	1,297	1,297	1,297	1,298
	Census Tract Total	3,332	6,606	8,600	9,683	10,931	12,307	13,966
821	821.01		3,400	3,380	3,380	3,380	3,380	3,380
	Census Tract Total	3,190	3,400	3,380	3,380	3,380	3,380	3,380
822	822.01		853	1,453	1,698	2,004	2,347	2,767
	822.02		960	968	968	968	968	968
	822.03		4,367	4,390	4,840	5,400	6,046	6,844
	Census Tract Total	4,922	6,180	6,810	7,506	8,372	9,361	10,579
823	823.01		13,317	13,287	15,566	18,401	21,564	25,427
	Census Tract Total	12,587	13,317	13,287	15,566	18,401	21,564	25,427
824	824.01		1,955	2,557	2,699	2,799	2,907	3,027
	Census Tract Total	1,988	1,955	2,557	2,699	2,799	2,907	3,027
825	825.01		678	1,359	1,504	1,680	1,875	2,113

(CONTINUED)

Historical and Forecasted Population  
Census and Subcensus Tract  
(January 1995)

Census Tract	Subcensus Tract	1990	1995	2000	2005	2010	2015	2020
825	825.02		11,519	11,795	12,267	12,526	12,791	13,062
	Census Tract Total	11,234	12,197	13,154	13,771	14,206	14,666	15,176
826	826.01		1,889	1,939	2,027	2,075	2,124	2,174
	826.02		7,848	8,448	8,949	9,423	9,936	10,538
	Census Tract Total	8,678	9,737	10,388	10,976	11,497	12,060	12,712
901	901.01		13	13	13	13	13	13
	901.02		38	38	39	39	40	40
	901.03		2,782	2,783	3,340	3,362	3,384	3,407
	901.04		3	3	3	3	3	3
	901.05		6,545	6,558	6,601	6,627	6,653	6,680
	901.06							
	Census Tract Total	8,573	9,381	9,394	9,995	10,043	10,093	10,143
905	905.01		2,605	2,671	2,721	2,759	2,796	2,833
	905.02		5,037	5,423	5,653	5,779	5,908	6,041
	Census Tract Total	4,709	7,642	8,094	8,373	8,538	8,704	8,874
909 /3	909.01		222	227	233	237	241	245
	Census Tract Total	176	222	227	233	237	241	245
910	910.01		24	25	26	27	28	28
	910.02		1,567	1,573	1,647	1,688	1,730	1,773
	Census Tract Total	1,257	1,591	1,598	1,674	1,715	1,758	1,801
911	911.01		11,836	12,154	12,491	12,675	12,864	13,058
	Census Tract Total	8,902	11,836	12,154	12,491	12,675	12,864	13,058
912	912.01		5,198	5,861	6,965	8,329	9,839	11,677
	912.02			1,113	1,269	1,463	1,687	1,964
	Census Tract Total	4,239	5,198	6,974	8,233	9,792	11,526	13,640
913	913.01		69	69	70	70	71	71
	913.02		113	117	118	118	119	119
	913.03		1,373	2,120	2,409	2,757	3,147	3,622
	913.04		7,527	9,675	11,380	13,431	15,711	18,482
	Census Tract Total	4,882	9,083	11,981	13,977	16,377	19,047	22,294
914	914.01		15,264	16,166	18,446	21,044	23,897	27,328

(CONTINUED)

Historical and Forecasted Population  
Census and Subcensus Tract  
(January 1995)

Census Tract	Subcensus Tract	1990	1995	2000	2005	2010	2015	2020
914	Census Tract Total	11,654	15,264	16,166	18,446	21,044	23,897	27,328
915	915.01		4,539	5,377	5,710	5,967	6,240	6,548
	915.02		1,467	2,145	2,396	2,665	2,949	3,280
	915.03		314	314	343	379	418	465
	Census Tract Total	4,006	6,320	7,835	8,449	9,010	9,608	10,293
916	916.01		7,045	7,124	7,997	8,937	9,968	11,198
	Census Tract Total	6,961	7,045	7,124	7,997	8,937	9,968	11,198
917	917.01		3,354	4,136	4,958	5,980	7,122	8,516
	917.02		1,477	2,309	2,401	2,509	2,633	2,786
	917.03		518	1,029	1,077	1,114	1,152	1,196
	917.04		2,479	2,803	3,166	3,602	4,087	4,673
	Census Tract Total	4,263	7,828	10,277	11,602	13,205	14,995	17,170
918	918.01		10,408	12,020	12,995	14,006	15,112	16,425
	Census Tract Total	7,932	10,408	12,020	12,995	14,006	15,112	16,425
919	919.01		342	375	379	382	385	387
	919.02		407	822	860	882	903	926
	919.03		493	519	528	533	539	544
	919.04		184	214	215	215	216	216
	919.05		375	1,213	1,261	1,287	1,315	1,342
	919.06		131	164	166	166	167	168
	919.07		306	421	427	430	434	437
	919.08		56	69	69	69	69	69
	919.09		373	391	394	395	397	398
	919.10		141	145	145	145	145	145
	919.11		151	158	158	159	159	159
	919.12		297	306	307	307	308	308
	Census Tract Total	2,627	3,257	4,794	4,909	4,971	5,035	5,100
920	920.01		2,143	2,425	2,515	2,565	2,616	2,667
	920.02		2,151	2,187	2,259	2,299	2,338	2,379
	920.03		2,202	2,369	2,441	2,480	2,519	2,560
	Census Tract Total	5,913	6,495	6,982	7,216	7,343	7,473	7,606

(CONTINUED)

Historical and Forecasted Population  
Census and Subcensus Tract  
(January 1995)

Census Tract	Subcensus Tract	1990	1995	2000	2005	2010	2015	2020
921	921.01		269	286	288	289	290	292
	921.02		417	506	515	520	525	530
	921.03		1,088	1,216	1,255	1,276	1,298	1,320
	921.04		723	743	746	748	750	752
	921.05		905	1,071	1,122	1,149	1,177	1,206
	921.06		1,160	1,213	1,236	1,249	1,262	1,275
	921.07		2,455	2,468	2,479	2,485	2,490	2,496
	Census Tract Total		5,828	7,018	7,502	7,641	7,717	7,793
922	922.01		380	411	416	419	422	425
	922.02		1,428	1,505	1,576	1,615	1,655	1,696
	922.03		6,032	6,781	7,149	7,404	7,674	7,971
	922.04		652	914	946	964	981	1,000
	922.05		3,332	3,999	4,159	4,247	4,336	4,428
	Census Tract Total		7,067	11,824	13,610	14,246	14,649	15,069
923	923.01		3,251	3,299	3,335	3,355	3,375	3,395
	Census Tract Total		3,463	3,251	3,299	3,335	3,355	3,375
924	924.01		4,191	4,227	4,275	4,301	4,328	4,356
	Census Tract Total		3,499	4,191	4,227	4,275	4,301	4,328
Fairfax County		818,584	879,401	943,333	1,000,461	1,058,252	1,120,870	1,193,430

Sources: U.S. Bureau of the Census, U.S. Census of Population and Housing: 1990; Summary Tape File 1A, Virginia. Fairfax County Office of Management and Budget: 1995 through 2020.

- 1/ Comprises part of the Town of Vienna (Vienna is composed of Census Tracts 607 through 610).
- 2/ Comprises part of the town of Herndon (Herndon is composed of Census Tracts 808 and 809).
- 3/ Town of Clifton (Clifton is composed of Census Tract 909).

# V. HOUSING UNIT INVENTORY

## HOUSING UNIT INVENTORY

As of January 1995, there were 328,151 dwelling units in Fairfax County, an increase of 6,144 units, or 1.9 percent, over the 1994 inventory of 322,007 units. Single-family detached units continue to account for a majority of the housing units (51.9 percent), followed by townhouses (20.8 percent), garden apartments (18.8 percent), and high-rise apartments (4.2 percent). Multiplex units comprise 2.1 percent of the total housing inventory, and mid-rise, mobile home, and duplex units account for the remaining 2.2 percent.

More than 55 percent of the County's increase in dwelling units occurred in the Bull Run and Upper Potomac Planning Districts. During 1994, 1,719 units were added to the housing inventory in the Bull Run District, and 1,665 units were added in the Upper Potomac District.

The supervisor district with the largest dwelling unit inventory was Sully, with 44,540 units. The Braddock District had the smallest dwelling unit inventory of 30,814 units. The largest number of single-family units were located in the Dranesville District (26,674). Providence District had the smallest number of single-family units (13,942), but the largest number of garden apartment units (13,714). Nearly 40 percent of the County's high-rise and mid-rise apartment units were located in the Mason District. Nearly 19 percent of the County's townhouse units were located in the Sully District. Table 5.1 shows the total number of housing units by year since 1978, with the number change and the percent change. Figure 5.1 charts the growth in housing units in the County from 1950 to 1995 by type of unit.

As of January 1995, the median market value of individually owned housing units was \$186,800. Thus, half of all owned housing units in the County had values exceeding \$186,800 and half had values below this level. This represents a increase of 1.3 percent from the 1994 estimated median housing value of \$184,400.

TABLE 5.1

Total Housing Units  
1978-1995

Year	Housing Units	Annual Change	
		Number	Percent
1978	192,776	—	—
1979	201,667	8,891	4.6%
1980	215,646	13,979	6.9%
1981	220,086	4,440	2.1%
1982	223,853	3,767	1.7%
1983	230,046	6,193	2.8%
1984	237,850	7,804	3.4%
1985	247,777	9,927	4.2%
1986	258,712	10,935	4.4%
1987	270,744	12,032	4.7%
1988	281,192	10,448	3.9%
1989	293,682	12,490	4.4%
1990	302,464	8,782	3.0%
1991	308,202	5,738	1.9%
1992	312,324	4,122	1.3%
1993	316,723	4,399	1.4%
1994	322,007	5,284	1.7%
1995	328,151	6,144	1.9%



Market value in this report refers to the estimated market value as of January 1995. Market value for each dwelling unit is derived from the 1995 tax assessment, adjusted to reflect the unit's market value, or the sales price if the unit sold during 1994. Table 5.2 shows, by supervisor district, the median market value of housing units and the percent change between 1994 and 1995. Table 5.3 shows, by planning district, the median market value of housing units and the percent change between 1994 and 1995.

TABLE 5.2

Median Market Value of Housing Units  
By Supervisor District  
1994 - 1995

Supervisor District	Median Value		Percent Change
	1994	1995	
Braddock	\$186,700	\$189,100	1.3%
Dranesville	260,600	263,900	1.3%
Hunter Mill	194,500	199,700	2.7%
Lee	156,600	157,600	0.6%
Mason	175,200	175,000	-0.1%
Mount Vernon	173,800	174,000	0.1%
Providence	174,800	175,900	0.6%
Springfield	200,000	204,200	2.1%
Sully	178,300	182,000	2.1%
<b>Fairfax County</b>	<b>\$184,400</b>	<b>\$186,800</b>	<b>1.3%</b>

Note: Median market value calculated on ungrouped data.

TABLE 5.3

Median Market Value of Housing Units  
By Planning District  
1994 - 1995

Planning District	Median Value		Percent Change
	1994	1995	
Annandale	\$186,700	\$188,300	0.9%
Baileys	147,900	146,400	-1.0%
Bull Run	163,600	167,200	2.2%
Fairfax	204,700	206,300	0.4%
Jefferson	164,400	165,000	0.9%
Lincolnia	171,000	172,200	0.7%
Lower Potomac	129,600	125,800	-2.9%
McLean	273,700	279,500	2.1%
Mount Vernon	164,900	166,700	1.1%
Pohick	193,900	198,000	2.1%
Rose Hill	171,300	171,500	0.1%
Springfield	164,800	165,800	0.6%
Upper Potomac	193,300	198,400	2.6%
Vienna	216,200	220,700	2.1%
<b>Fairfax County</b>	<b>\$184,400</b>	<b>\$186,800</b>	<b>1.3%</b>

Note: Median market value calculated on ungrouped data.

The supervisor district in the County with the highest median market value of housing units, as of January 1995, was the Dranesville District (\$263,900). The district with the lowest median market value was the Lee District (\$157,600).

The supervisor district with the greatest percentage of dwelling units with values above \$350,000 was the Dranesville Supervisor District with 37.2 percent. County-wide, a total of 8.8 percent of housing units had values above \$350,000. The supervisor district with the greatest percentage of dwelling unit values below \$80,000 was the Mason Supervisor District with 12.2 percent. A total of 5.2 percent of housing units in the County had market values below \$80,000.

The planning district in the County with the highest median market value of housing units, as of January 1995, was the McLean Planning District (\$279,500). The Lower Potomac Planning District had the lowest median market value in 1995, at \$125,800.

The planning district in the County with the greatest percentage of housing units with values above \$350,000 was the McLean Planning District, with 34.6 percent. Further, looking at only Single Family units in McLean, fully 42.1 percent had values above \$350,000. Baileys Planning District had the greatest percentage of housing units with values below \$80,000, at 25.5 percent. Of the units with values below \$80,000 in Baileys, 96.3% of these were condominium apartment units.

Figure 5.2 presents, by census tract, the median market value of housing units in the County, as of January 1995. Highest median market values are concentrated in the Great Falls area, with high median market values also located in the Clifton / Fairfax Station and McLean areas. Darker areas on the map correspond to census tracts with higher median market values.

Figure 5.1

# Housing Units by Structure Type

Fairfax County, 1950 to 1995

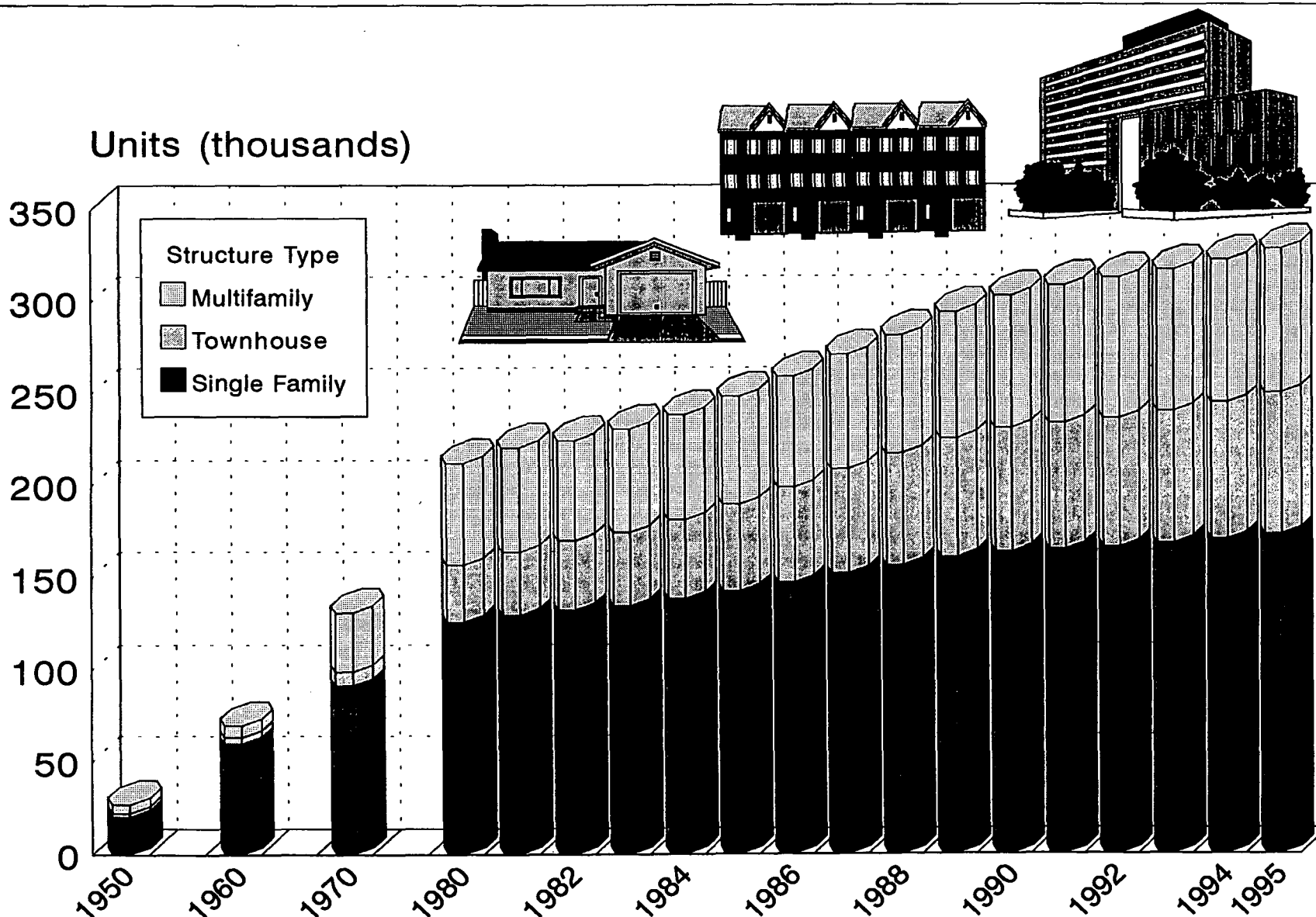

Sources: U.S. Bureau of the Census; Fairfax County Office of Management and Budget.

# Median Market Value of Housing Units

## By Census Tract January 1995

Fairfax County, Virginia

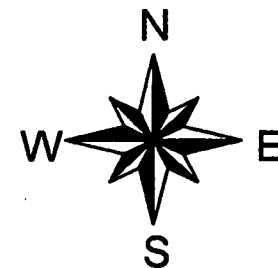

Source: Urban Development Information System,  
Office of Management and Budget.

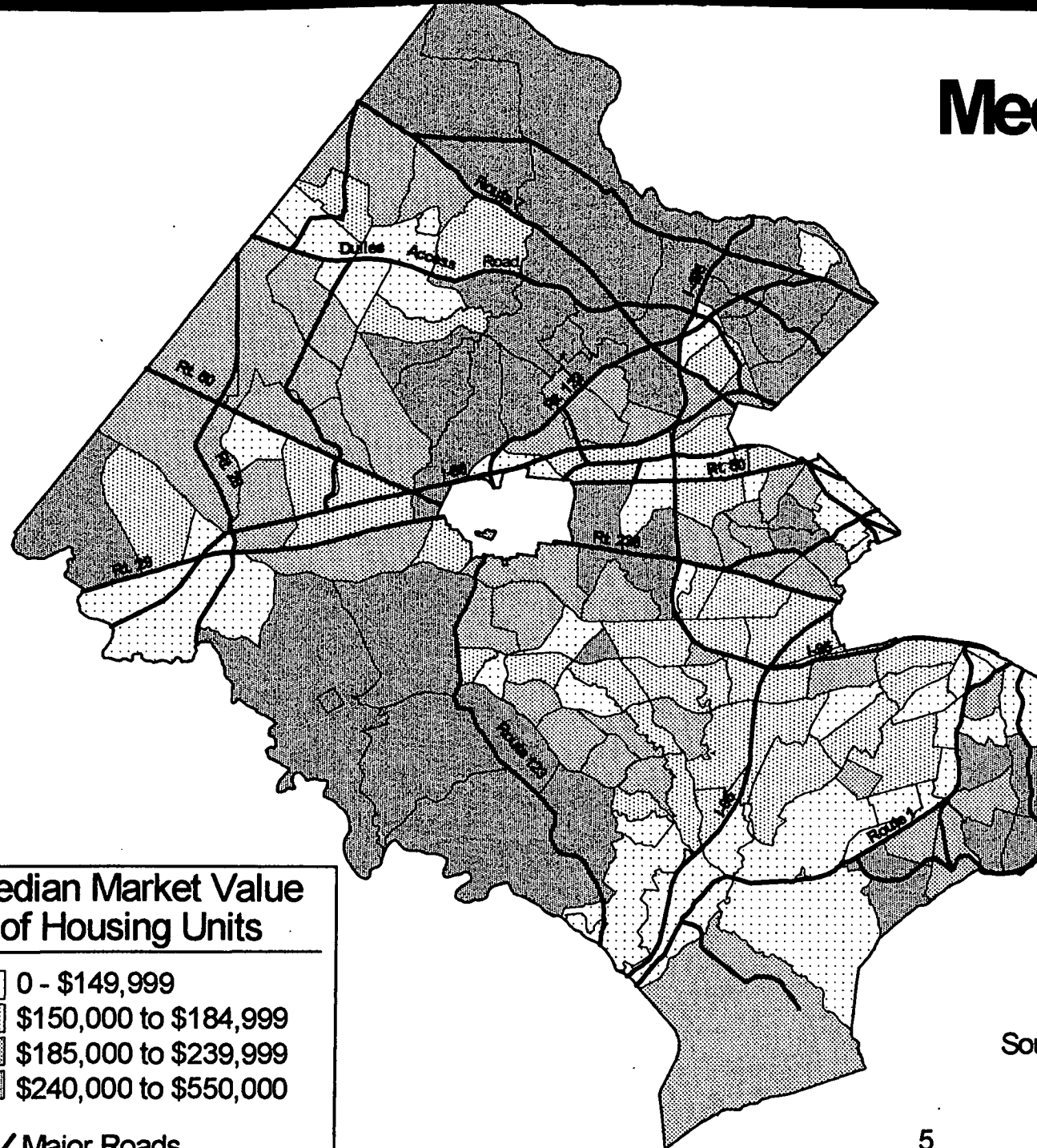

**Median Market Value of Housing Units**

- 0 - \$149,999
- \$150,000 to \$184,999
- \$185,000 to \$239,999
- \$240,000 to \$550,000

Major Roads

Housing Unit Inventory  
Supervisor District  
(January 1995)

Supervisor District	Single Family	Duplex	Townhouse	Multiplex	Garden Apartment	Mid Rise Apartment	High Rise Apartment	Mobile Home	TOTAL UNITS
Braddock	19,549	184	6,029	186	4,343	267		256	30,814
Dranesville 1/	26,674	68	4,271	87	2,099	496	500		34,195
Hunter Mill 2/	18,568	19	8,415	1,259	7,885	697	285		37,128
Lee	15,848	574	9,533	1,443	9,788			971	38,157
Mason	16,236	34	4,104	546	9,399	1,011	5,658		36,988
Mount Vernon	15,609	1,185	5,566	750	5,342	130	3,960	325	32,867
Providence	13,942	11	8,483	743	13,714	249	3,484		40,626
Springfield 3/	21,308	188	9,022	496	1,820	2			32,836
Sully	22,573	7	12,827	1,326	7,307			500	44,540
FAIRFAX COUNTY	170,307	2,270	68,250	6,836	61,697	2,852	13,887	2,052	328,151

Housing Unit Inventory  
Towns  
(January 1995)

Town	Single Family	Duplex	Townhouse	Multiplex	Garden Apartment	Mid Rise Apartment	High Rise Apartment	Mobile Home	TOTAL UNITS
Town of Clifton	68								68
Town of Herndon	2,698	63	1,721	7	1,871				6,360
Town of Vienna	4,542	7	406	31	524				5,510
TOWNS TOTAL	7,308	70	2,127	38	2,395				11,938

Note: Figures exclude group quarters (i.e. Lorton Reformatory, Fort Belvoir, nursing homes and religious quarters).

- 1/ Includes the Town of Herndon.
- 2/ Includes the Town of Vienna.
- 3/ Includes the Town of Clifton.

Housing Unit Inventory  
 Planning District  
 (January 1995)

Planning District	Single Family	Duplex	Townhouse	Multiplex	Garden Apartment	Mid Rise Apartment	High Rise Apartment	Mobile Home	TOTAL UNITS
Annandale	15,833	12	3,107	255	4,966	513	471		25,157
Baileys	5,074	16	783	81	5,025	765	5,187		16,931
Bull Run	14,549	5	10,935	1,326	5,802			500	33,117
Fairfax	8,338	2	2,844	289	6,876	249		256	18,854
Jefferson	8,463	11	2,242	117	6,299		1,230		18,362
Lincolnia	1,483	4	1,607	210	2,267				5,571
Lower Potomac	1,399	8	1,551	601	1,438				4,997
McLean	16,308	5	1,548	412	3,099	496	2,200		24,068
Mount Vernon	15,023	1,699	2,584	1,568	9,749	130	3,960	1,296	36,009
Pohick 1/	27,452	416	13,898	522	1,448				43,736
Rose Hill	7,884	6	5,161		3,216				16,267
Springfield	8,144		5,362	184	1,547	2			15,239
Upper Potomac 2/	27,288	75	12,163	960	8,715	423	285		49,909
Vienna 3/	13,069	11	4,465	311	1,250	274	554		19,934
FAIRFAX COUNTY	170,307	2,270	68,250	6,836	61,697	2,852	13,887	2,052	328,151

NOTE: Figures exclude group quarters (i.e. Lorton Reformatory, Fort Belvoir, nursing homes and religious quarters).

- 1/ Includes the Town of Clifton.
- 2/ Includes the Town of Herndon.
- 3/ Includes the Town of Vienna.

Housing Unit Inventory  
Sewershed  
(January 1995)

Sewershed Code	Single Family	Duplex	Townhouse	Multiplex	Garden Apartment	Mid Rise Apartment	High Rise Apartment	Mobile Home	TOTAL UNITS
A1	5,816		716		283				6,815
A2	14		232						246
A3	205		565						770
B1	887	2	368			414			1,671
B2	3,831		1,191	168	534				5,724
B3	617								617
B5 1/	2,698	63	1,722	7	1,707				6,197
C1	896								896
C2	1,053		1						1,054
D1	2,470	2							2,472
D2	1,876		2,689	186	3,349	288	61		8,449
D3 2/	16,610	20	4,419	630	2,882	409	1,392		26,362
E1	1,965		234	332	2,871	144	532		6,078
E2	482								482
F	1,815		324				500		2,639
G1	7,651	2	1,864	80	1,383	112	1,230		12,322
G2	944					240			1,184
G3	664		35						699
G4	339								339
H1	1,180	1	354		2,360	359	1,487		5,741
H2					128		3,281		3,409
H3	184								184
I1	13,506	28	2,077	198	7,823	406	419		24,457
I2	1,168		36						1,204
I3	9,517	16	4,845	465	3,109	246	219		18,417
I4	45								45
I5	237		35						272

(CONTINUED)

Note: Figures exclude group quarters (i.e. Lorton Reformatory, Fort Belvoir, nursing homes and religious quarters).

- 1/ Town of Herndon.
- 2/ Comprises part of the Town of Vienna.
- 3/ Includes the Town of Clifton.

Housing Unit Inventory  
Sewarshed  
(January 1995)

Sewarshed Code	Single Family	Duplex	Townhouse	Multiplex	Garden Apartment	Mid Rise Apartment	High Rise Apartment	Mobile Home	TOTAL UNITS
J1	3,700	1,134	332		1,329		1,587		8,082
J2	834	12	100		323		1,850	91	3,210
J3	1,118	197	154		496				1,965
J4	727	5	20		931		523		2,206
K	8,231	342	1,318	931	4,601	130		1,086	16,639
L	6,289	11	4,496	637	5,241			119	16,793
M0	804		123		921			256	2,104
M1	699		1,467	128	1,603	249			4,146
M2 2/	10,964	2	4,734	441	6,983	267	806		24,197
M3	6,133	2	227						6,362
M4	4,829		1,883		1,161	2			7,875
M5	1,351		1,194	160					2,705
M6	1,424		2,490	24					3,938
M7	30	2			195				227
M8	18								18
M9	319		696		1,476				2,491
N1	18,764	370	13,475	1,123	2,691				36,423
N2	3,641	46	1,750						5,437
O1	435	2							437
P	109	2							111
P1	71								71
P2	176								176
P3	803								803
Q1	2,163								2,163
R1	2,574	4							2,578
R2	226								226
R3 3/	69								69

(CONTINUED)

Note: Figures exclude group quarters (i.e. Lorton Reformatory, Fort Belvoir, nursing homes and religious quarters).

- 1/ Town of Herndon.
- 2/ Comprises part of the Town of Vienna.
- 3/ Includes the Town of Clifton.



Housing Unit Inventory  
Sewershed  
(January 1995)

Sewershed Code	Single Family	Duplex	Townhouse	Multiplex	Garden Apartment	Mid Rise Apartment	High Rise Apartment	Mobile Home	TOTAL UNITS
R4	231								231
S1	3,199	3	3,580		1,248				8,030
S2	212								212
T1	1,034							500	1,534
T2	3,609		1,705	580	229				6,123
T3	3,454		2,239						5,693
T4	2,386	2	1,246	128	2,868				6,630
T5	2,293		2,695	618	2,276				7,882
T6	54								54
T7	664		619		282				1,565
FAIRFAX COUNTY	170,307	2,270	68,250	6,836	61,697	2,852	13,887	2,052	328,151

Note: Figures exclude group quarters (i.e. Lorton Reformatory, Fort Belvoir, nursing homes and religious quarters).

- 1/ Town of Herndon.
- 2/ Comprises part of the Town of Vienna.
- 3/ Includes the Town of Clifton.

Housing Unit Inventory  
Census and Subcensus Tract  
(January 1995)

Census Tract	Subcensus Tract	Single Family	Duplex	Townhouse	Multiplex	Garden Apartment	Mid Rise Apartment	High Rise Apartment	Mobile Home	TOTAL UNITS
151	151.01	403		74						477
	151.02	319	2			103			91	515
	151.03	307								307
	Census Tract Total	1,029	2	74		103			91	1,299
152	152.01	200	2	131						333
	152.02	18		20		931		523		1,492
	152.03	117								117
	152.04									
	Census Tract Total	335	2	151		931		523		1,942
153	153.01	224	35	23						282
	153.02	269	204			147				620
	153.03	180	291							471
	153.04	100								100
	Census Tract Total	773	530	23		147				1,473
154	154.01	602		156		1,555			115	2,428
	154.02	407								407
	154.03	123		227		55				405
	Census Tract Total	1,132		383		1,610			115	3,240
155	155.01	438		400		209	130			1,177
	155.02	688								688
	155.03	265								265
	155.04	90								90
	Census Tract Total	1,481		400		209	130			2,220
156	156.01	548								548
	156.02	79								79
	156.03	291	2							293
	156.04	116								116
	Census Tract Total	1,034	2							1,036
157	157.01	432								432
	157.02	747								747
	157.03	191	2							193

(CONTINUED)

Housing Unit Inventory  
Census and Subcensus Tract  
(January 1995)

Census Tract	Subcensus Tract	Single Family	Duplex	Townhouse	Multiplex	Garden Apartment	Mid Rise Apartment	High Rise Apartment	Mobile Home	TOTAL UNITS
157	Census Tract Total	1,370	2							1,372
158	158.01	668								668
	158.02	530								530
	158.03	462								462
	Census Tract Total	1,660								1,660
159	159.01	851								851
	159.02	185	5							190
	159.03									
	159.04	125								125
	Census Tract Total	1,161	5							1,166
160	160.01	111	2			169				282
	160.02	484	2		149	242			119	996
	160.03	296								296
	Census Tract Total	891	4		149	411			119	1,574
161	161.01	141				45				186
	161.02	97								97
	161.03	624								624
	161.04	461								461
	Census Tract Total	1,323				45				1,368
162	162.01									
	162.02									
	Census Tract Total									
163	163.01	249								249
	163.02	465	4							469
	Census Tract Total	714	4							718
201	201.01	436								436
	201.02	467		140						607
	Census Tract Total	903		140						1,043
202	202.01	503		719						1,222
	202.02	539		309						848
	Census Tract Total	1,042		1,028						2,070

(CONTINUED)

Housing Unit Inventory  
Census and Subcensus Tract  
(January 1995)

Census Tract	Subcensus Tract	Single Family	Duplex	Townhouse	Multiplex	Garden Apartment	Mid Rise Apartment	High Rise Apartment	Mobile Home	TOTAL UNITS
203	203.01	638								638
	203.02	386	2	284						672
	203.03	242								242
	203.04	210		80						290
	Census Tract Total	1,476	2	364						1,842
204	204.01	25	273			66		1,222		1,586
	Census Tract Total	25	273			66		1,222		1,586
205	205.01	82	303	140		382		2,215		3,122
	205.02	171	8							179
	Census Tract Total	253	311	140		382		2,215		3,301
206	206.01	60	120							180
	206.02		360			67				427
	206.03	350	78	67		556				1,051
	Census Tract Total	410	558	67		623				1,658
207	207.01	625								625
	207.02	129								129
	207.03	548								548
	Census Tract Total	1,302								1,302
208	208.01	335								335
	208.02	265								265
	208.03	481	2	71						554
	Census Tract Total	1,081	2	71						1,154
210	210.01	280								280
	210.02	61		583						644
	210.03	178		64						242
	210.04	287								287
	Census Tract Total	806		647						1,453
211	211.01	496		1,584	24					2,104
	211.02	333		622		538				1,493
	211.03	10		182						192
	Census Tract Total	839		2,388	24	538				3,789

(CONTINUED)

Housing Unit Inventory  
Census and Subcensus Tract  
(January 1995)

Census Tract	Subcensus Tract	Single Family	Duplex	Townhouse	Multiplex	Garden Apartment	Mid Rise Apartment	High Rise Apartment	Mobile Home	TOTAL UNITS
212	212.01	691								691
	Census Tract Total	691								691
213	213.01	913		438						1,351
	213.02	42		62						104
	Census Tract Total	955		500						1,455
214	214.01	199	2			727				928
	214.02	285	6	25		1,186				1,502
	Census Tract Total	484	8	25		1,913				2,430
215	215.01	210				801			971	1,982
	Census Tract Total	210				801			971	1,982
216	216.01	95		72	931	323				1,421
	216.02	85		112		340				537
	Census Tract Total	180		184	931	663				1,958
217	217.01	1,082		810	131	656				2,679
	Census Tract Total	1,082		810	131	656				2,679
218	218.01	190	2	327	357	1,189				2,065
	Census Tract Total	190	2	327	357	1,189				2,065
219	219.01									
	Census Tract Total									
220	220.01	1								1
	220.02									
	220.03	268		224						492
	220.04	10								10
	220.05	30	2			195				227
	Census Tract Total	309	2	224		195				730
221	221.01	205		636		990				1,831
	221.02	1								1
	221.03	88			321					409
	221.04	31	2	638	280	1				952
	221.05	14		53		252				319
	221.06	38								38

(CONTINUED)

Housing Unit Inventory  
Census and Subcensus Tract  
(January 1995)

Census Tract	Subcensus Tract	Single Family	Duplex	Townhouse	Multiplex	Garden Apartment	Mid Rise Apartment	High Rise Apartment	Mobile Home	TOTAL UNITS
221	Census Tract Total	377	2	1,327	601	1,243				3,550
222	222.01									
	Census Tract Total									
223	223.01	371	2	670		1,476				2,519
	Census Tract Total	371	2	670		1,476				2,519
224	224.01	308		1,762		1,202				3,272
	224.02	325		144						469
	Census Tract Total	633		1,906		1,202				3,741
301	301.01	465								465
	301.02	1,056								1,056
	301.03	329		652						981
	Census Tract Total	1,850		652						2,502
302	302.01	2,425	2	1,423						3,850
	Census Tract Total	2,425	2	1,423						3,850
304	304.01	1,142		326						1,468
	304.02	855								855
	Census Tract Total	1,997		326						2,323
305	305.01	567								567
	Census Tract Total	567								567
306	306.01	279		106		166				551
	306.02	350								350
	306.03	257				220				477
	306.04	435								435
	Census Tract Total	1,321		106		386				1,813
307	307.01	217								217
	307.02	338								338
	307.03	373								373
	Census Tract Total	928								928
308	308.01	1,351		1,153		820	2			3,326
	Census Tract Total	1,351		1,153		820	2			3,326
309	309.01	847		1,183		242				2,272

(CONTINUED)

Housing Unit Inventory  
Census and Subcensus Tract  
(January 1995)

Census Tract	Subcensus Tract	Single Family	Duplex	Townhouse	Multiplex	Garden Apartment	Mid Rise Apartment	High Rise Apartment	Mobile Home	TOTAL UNITS
309	Census Tract Total	847		1,183		242				2,272
310	310.01	762		1,318	237					2,317
	Census Tract Total	762		1,318	237					2,317
313	313.01	1,091		302						1,393
	Census Tract Total	1,091		302						1,393
314	314.01	776		425	99					1,300
	Census Tract Total	776		425	99					1,300
315	315.01	1,154		676	160					1,990
	Census Tract Total	1,154		676	160					1,990
316	316.01	355		187		242				784
	316.02	552		205		99				856
	316.03	3								3
	Census Tract Total	910		392		341				1,643
318	318.01	821	52	1,561						2,434
	Census Tract Total	821	52	1,561						2,434
319	319.01	1,048		1						1,049
	Census Tract Total	1,048		1						1,049
320	320.01	492		617						1,109
	Census Tract Total	492		617						1,109
321	321.01	501	128	181	186	448				1,444
	Census Tract Total	501	128	181	186	448				1,444
322	322.01	560	184	1,239		580				2,563
	Census Tract Total	560	184	1,239		580				2,563
323	323.01	703		410						1,113
	323.02	308		73		100				481
	Census Tract Total	1,011		483		100				1,594
324	324.01	2,132		493						2,625
	Census Tract Total	2,132		493						2,625
325	325.01	1,391		432						1,823
	Census Tract Total	1,391		432						1,823
326	326.01	1,109	2	393						1,504

(CONTINUED)

Housing Unit Inventory  
Census and Subcensus Tract  
(January 1995)

Census Tract	Subcensus Tract	Single Family	Duplex	Townhouse	Multiplex	Garden Apartment	Mid Rise Apartment	High Rise Apartment	Mobile Home	TOTAL UNITS
326	Census Tract Total	1,109	2	393						1,504
327	327.01	1,040		1,441		78				2,559
	Census Tract Total	1,040		1,441		78				2,559
328	328.01	264		482						746
	Census Tract Total	264		482						746
401	401.01	251		150		300				701
	401.02	1,020								1,020
	401.03	441			161	387				989
	Census Tract Total	1,712		150	161	687				2,710
402	402.01	1				296				297
	402.02	415		579		1,088				2,082
	402.03									
	402.04	131								131
	Census Tract Total	547		579		1,384				2,510
403	403.01	471								471
	403.02	447								447
	Census Tract Total	918								918
405	405.01	49		46						95
	405.02	434								434
	405.03	1,569								1,569
	405.04									
	Census Tract Total	2,052		46						2,098
406	406.01	678							256	934
	Census Tract Total	678							256	934
407	407.01	1,660		137						1,797
	407.02	989								989
	Census Tract Total	2,649		137						2,786
408	408.01	706	2	33		120				861
	408.02	97								97
	408.03	437								437
	408.04	668								668

(CONTINUED)



Housing Unit Inventory  
Census and Subcensus Tract  
(January 1995)

Census Tract	Subcensus Tract	Single Family	Duplex	Townhouse	Multiplex	Garden Apartment	Mid Rise Apartment	High Rise Apartment	Mobile Home	TOTAL UNITS
408	408.05									
	Census Tract Total	1,908	2	33		120				2,063
501	501.01	92		231	117	1,032				1,472
	501.02	203				150				353
	501.03	350				64				414
	Census Tract Total	645		231	117	1,246				2,239
502	502.01			512						512
	502.02	243								243
	502.03	150				25				175
	502.04	392								392
	Census Tract Total	785		512		25				1,322
503	503.01	304								304
	503.02	294								294
	503.03	194	5	99		551				849
	503.04	227								227
	Census Tract Total	1,019	5	99		551				1,674
504	504.01	275	2	94						371
	504.02	338								338
	504.03	229								229
	Census Tract Total	842	2	94						938
505	505.01	360								360
	505.02	303								303
	505.03	224								224
	Census Tract Total	887								887
506	506.01	191								191
	506.02	391		96		1,190				1,677
	506.03	298								298
	506.04	188	2							190
	506.05	257								257
	506.06	375								375
	506.07	172		2						174

(CONTINUED)

Housing Unit Inventory  
Census and Subcensus Tract  
(January 1995)

Census Tract	Subcensus Tract	Single Family	Duplex	Townhouse	Multiplex	Garden Apartment	Mid Rise Apartment	High Rise Apartment	Mobile Home	TOTAL UNITS
506	Census Tract Total	1,872	4	96		1,190				3,162
507	507.01	520		445						965
	507.02	291	2			887		252		1,432
	Census Tract Total	811	2	445		887		252		2,397
508	508.01	294								294
	508.02	451								451
	508.03	223				184				407
	Census Tract Total	968				184				1,152
509	509.01	286								286
	509.02	296								296
	Census Tract Total	582								582
510	510.01	410								410
	510.02	492								492
	Census Tract Total	902								902
511	511.01	360								360
	511.02	451								451
	Census Tract Total	811								811
512	512.01	226								226
	512.02	308								308
	512.03	99								99
	Census Tract Total	633								633
513	513.01	406	2	23						431
	513.02	303	2	34		108				447
	Census Tract Total	709	4	57		108				878
514	514.01					204				204
	514.02					504		220		724
	514.03			102		225				327
	Census Tract Total			102		933		220		1,255
515	515.01	48		36		588	310			982
	515.02	325		38	81			829		1,273
	515.03	245		186		281	49			761

(CONTINUED)

Housing Unit Inventory  
Census and Subcensus Tract  
(January 1995)

Census Tract	Subcensus Tract	Single Family	Duplex	Townhouse	Multiplex	Garden Apartment	Mid Rise Apartment	High Rise Apartment	Mobile Home	TOTAL UNITS
515	515.04	63		30		450		438		981
	Census Tract Total	681		290	81	1,319	359	1,267		3,997
516	516.01	12					400	419		831
	516.02	80								80
	516.03	98		36		656				790
	516.04	166				444				610
	516.05	215				196				411
	Census Tract Total	571		36		1,296	400	419		2,722
518	518.01	417		48						465
	518.02	173								173
	518.03	426								426
	Census Tract Total	1,016		48						1,064
519	519.01	440	4	1,030	210	525				2,209
	Census Tract Total	440	4	1,030	210	525				2,209
520	520.01	523		354			246			1,123
	Census Tract Total	523		354			246			1,123
521	521.01	119								119
	521.02	378	2	332				219		931
	521.03	315	2	228						545
	521.04	292	2	69	255					618
	521.05	255		131						386
	Census Tract Total	1,359	6	760	255			219		2,599
522	522.01	221		336		881				1,438
	522.02	383								383
	522.03	352								352
	Census Tract Total	956		336		881				2,173
523	523.01	1		389		2,482	267			3,139
	Census Tract Total	1		389		2,482	267			3,139
524	524.01	507								507
	524.02	345								345
	524.03	284								284

(CONTINUED)

Housing Unit Inventory  
Census and Subcensus Tract  
(January 1995)

Census Tract	Subcensus Tract	Single Family	Duplex	Townhouse	Multiplex	Garden Apartment	Mid Rise Apartment	High Rise Apartment	Mobile Home	TOTAL UNITS
524	524.04	326				412				738
	524.05	142		327						469
	Census Tract Total	1,604		327		412				2,343
525	525.01	286								286
	525.02	384	2							386
	525.03	337		10						347
	525.04	264		224		1,065				1,553
	Census Tract Total	1,271	2	234		1,065				2,572
526	526.01	365				366				731
	526.02	2		148		311				461
	526.03	75		195						270
	Census Tract Total	442		343		677				1,462
527	527.01	303	12	250		1,151	6			1,722
	Census Tract Total	303	12	250		1,151	6			1,722
528	528.01	350				218		3,281		3,849
	Census Tract Total	350				218		3,281		3,849
601	601.01	338								338
	601.02	658								658
	601.03	261								261
	Census Tract Total	1,257								1,257
602	602.01	489								489
	602.02	62								62
	602.03	644								644
	Census Tract Total	1,195								1,195
603	603.01	241								241
	603.02	660								660
	Census Tract Total	901								901
604	604.01	235								235
	604.02	416		180		217	274			1,087
	604.03	151								151
	Census Tract Total	802		180		217	274			1,473

(CONTINUED)

Housing Unit Inventory  
Census and Subcensus Tract  
(January 1995)

Census Tract	Subcensus Tract	Single Family	Duplex	Townhouse	Multiplex	Garden Apartment	Mid Rise Apartment	High Rise Apartment	Mobile Home	TOTAL UNITS
605	605.01	570	2	70						642
	605.02	279		385		13				677
	605.03	296	1							297
	605.04	67		142						209
	605.05	231	1	334						566
	Census Tract Total	1,443	4	931		13				2,391
606	606.01	147								147
	606.02	1,103								1,103
	Census Tract Total	1,250								1,250
607 /1	607.01	2,176	2	214		303				2,695
	Census Tract Total	2,176	2	214		303				2,695
608 /1	608.01	875		32	31	185				1,123
	Census Tract Total	875		32	31	185				1,123
609 /1	609.01	775		84						859
	Census Tract Total	775		84						859
610 /1	610.01	716	5	76		36				833
	Census Tract Total	716	5	76		36				833
611	611.01	640								640
	611.02	1,062		123	275	300				1,760
	Census Tract Total	1,702		123	275	300				2,400
612	612.01	194								194
	612.02	975		39						1,014
	612.03	70								70
	612.04	10								10
	Census Tract Total	1,249		39						1,288
615	615.01	201		23						224
	615.02	270								270
	615.03	174		274						448
	615.04	22		601						623
	615.05	89								89
	Census Tract Total	756		898						1,654

(CONTINUED)

Housing Unit Inventory  
Census and Subcensus Tract  
(January 1995)

Census Tract	Subcensus Tract	Single Family	Duplex	Townhouse	Multiplex	Garden Apartment	Mid Rise Apartment	High Rise Apartment	Mobile Home	TOTAL UNITS
616	616.01	131		536	5					672
	616.02	309		44						353
	616.04	9				783				792
	616.05	50		312						362
	616.06	2								2
	Census Tract Total	501		892	5	783				2,181
617	617.01	31		1,058		196		554		1,839
	617.02	158								158
	Census Tract Total	189		1,058		196		554		1,997
618	618.01	66				313				379
	618.02	18		1,135	128	690	249			2,220
	Census Tract Total	84		1,135	128	1,003	249			2,599
619	619.02	232		176		1,521				1,929
	Census Tract Total	232		176		1,521				1,929
701	701.01	281								281
	701.02	447								447
	701.03	59								59
	701.04	134		35						169
	Census Tract Total	921		35						956
702	702.01	2								2
	Census Tract Total	2								2
703	703.01	667								667
	703.02	127								127
	703.03	299								299
	Census Tract Total	1,093								1,093
704	704.01	295		227						522
	704.02	43								43
	704.03	358								358
	704.04	258								258
	704.05	498								498
	Census Tract Total	1,452		227						1,679

(CONTINUED)

Housing Unit Inventory  
Census and Subcensus Tract  
(January 1995)

Census Tract	Subcensus Tract	Single Family	Duplex	Townhouse	Multiplex	Garden Apartment	Mid Rise Apartment	High Rise Apartment	Mobile Home	TOTAL UNITS
705	705.01	110								110
	705.02	328								328
	705.03	431		281						712
	705.04	294								294
	705.05	157								157
	705.06	3						500		503
	Census Tract Total	1,323			281			500		2,104
706	706.01	179								179
	706.02	126		48						174
	706.03	244		23			144			411
	706.04	158		13						171
	Census Tract Total	707		84			144			935
707	707.01	278		7						285
	707.02	397								397
	707.03	279	1							280
	707.04	378								378
	707.05	196								196
	707.06	257								257
	Census Tract Total	1,785	1	7						1,793
708	708.01	240		32						272
	708.02	608	1	174						783
	Census Tract Total	848	1	206						1,055
709	709.01	493					240			733
	709.02	495		224						719
	709.03	255								255
	709.04	77		251						328
	709.05	323	1	22						346
	709.06	105								105
	Census Tract Total	1,748	1	497			240			2,486
710	710.01	58								58
	710.02	220								220

(CONTINUED)

Housing Unit Inventory  
Census and Subcensus Tract  
(January 1995)

Census Tract	Subcensus Tract	Single Family	Duplex	Townhouse	Multiplex	Garden Apartment	Mid Rise Apartment	High Rise Apartment	Mobile Home	TOTAL UNITS
710	710.03	178			80					258
	Census Tract Total	456			80					536
711	711.01	157		17						174
	711.02	206								206
	711.03	267								267
	711.04	306								306
	711.05	245								245
	711.06	335					228	112		675
	711.07	190								190
	711.08	367								367
	Census Tract Total	2,073			17		228	112		
712	712.01	1								1
	712.02									
	712.03	44		178						222
	712.04	45		16	332	1,869		532		2,794
	Census Tract Total	90		194	332	1,869		532		3,017
713	713.01	269		638		1,155		1,230		3,292
	713.02	554		49						603
	Census Tract Total	823		687		1,155		1,230		3,895
714	714.01	742		523		414				1,679
	714.02	254				639				893
	Census Tract Total	996		523		1,053				2,572
801	801.01	373								373
	801.02	216		1						217
	801.03	208								208
	801.04	260								260
	801.05	203								203
	Census Tract Total	1,260			1					
802	802.01	315								315
	802.02	448								448
	802.03	512								512

(CONTINUED)



Housing Unit Inventory  
Census and Subcensus Tract  
(January 1995)

Census Tract	Subcensus Tract	Single Family	Duplex	Townhouse	Multiplex	Garden Apartment	Mid Rise Apartment	High Rise Apartment	Mobile Home	TOTAL UNITS
802	802.04					1,002		1,168		2,170
	802.05									
	Census Tract Total	1,275				1,002		1,168		3,445
803	803.01	856								856
	803.02	250								250
	803.03	824	2							826
	803.04	1								1
	Census Tract Total	1,931	2							1,933
804	804.01	591								591
	804.02	632								632
	804.03	369								369
	804.04	364								364
	804.05	772								772
	Census Tract Total	2,728								2,728
805	805.01	1,691								1,691
	805.02	1,515		219						1,734
	805.03	653		909	168	274				2,004
	Census Tract Total	3,859		1,128	168	274				5,429
808 /2	808.01	1,168	3	851		494				2,516
	Census Tract Total	1,168	3	851		494				2,516
809 /2	809.01	1,530	60	870	7	1,377				3,844
	Census Tract Total	1,530	60	870	7	1,377				3,844
810	810.01	205		798						1,003
	Census Tract Total	205		798						1,003
811	811.01	30								30
	811.02	315		270		283				868
	811.03	1,061								1,061
	811.04	1,268								1,268
	Census Tract Total	2,674		270		283				3,227
812	812.01	1,054	2	546		694				2,296
	Census Tract Total	1,054	2	546		694				2,296

(CONTINUED)

Housing Unit Inventory  
Census and Subcensus Tract  
(January 1995)

Census Tract	Subcensus Tract	Single Family	Duplex	Townhouse	Multiplex	Garden Apartment	Mid Rise Apartment	High Rise Apartment	Mobile Home	TOTAL UNITS
814	814.01	1,109		1,042	85	222		224		2,682
	Census Tract Total	1,109		1,042	85	222		224		2,682
815	815.01	763								763
	Census Tract Total	763								763
816	816.01	463								463
	816.02	557								557
	Census Tract Total	1,020								1,020
817	817.01	547								547
	817.02	542								542
	817.03	616								616
	817.04	304		399		1,072				1,775
	Census Tract Total	2,009		399		1,072				3,480
819	819.01	153		325		922				1,400
	819.02	460								460
	Census Tract Total	613		325		922				1,860
820	820.01	861		625	140	334				1,960
	820.02	154		320						474
	Census Tract Total	1,015		945	140	334				2,434
821	821.01	90		517	46	728	48	61		1,490
	Census Tract Total	90		517	46	728	48	61		1,490
822	822.01			63		260				323
	822.02	50		319						369
	822.03	74		381		1,365	240			2,060
	Census Tract Total	124		763		1,625	240			2,752
823	823.01	571	10	2,512	514	1,762	135			5,504
	Census Tract Total	571	10	2,512	514	1,762	135			5,504
824	824.01	623								623
	Census Tract Total	623								623
825	825.01	216								216
	825.02	3,309		446						3,755
	Census Tract Total	3,525		446						3,971

(CONTINUED)

Housing Unit Inventory  
Census and Subcensus Tract  
(January 1995)

Census Tract	Subcensus Tract	Single Family	Duplex	Townhouse	Multiplex	Garden Apartment	Mid Rise Apartment	High Rise Apartment	Mobile Home	TOTAL UNITS
826	826.01	602								602
	826.02	1,570		1,149						2,719
	Census Tract Total	2,172		1,149						3,321
901	901.01	4								4
	901.02	12								12
	901.03	546							500	1,046
	901.04	1								1
	901.05	1,446		647		228				2,321
	901.06									
	Census Tract Total	2,009		647		228			500	3,384
905	905.01	156		311		748				1,215
	905.02	1,501	2	119						1,622
	Census Tract Total	1,657	2	430		748				2,837
909 /3	909.01	68								68
	Census Tract Total	68								68
910	910.01	8								8
	910.02	497								497
	Census Tract Total	505								505
911	911.01	2,172		2,052						4,224
	Census Tract Total	2,172		2,052						4,224
912	912.01	365		1,477		252				2,094
	912.02									
	Census Tract Total	365		1,477		252				2,094
913	913.01	22								22
	913.02	36								36
	913.03	217		73		282				572
	913.04	494		980	618	1,148				3,240
	Census Tract Total	769		1,053	618	1,430				3,870
914	914.01	2,053		3,231		516				5,800
	Census Tract Total	2,053		3,231		516				5,800
915	915.01	1,439		1						1,440

(CONTINUED)

Housing Unit Inventory  
Census and Subcensus Tract  
(January 1995)

Census Tract	Subcensus Tract	Single Family	Duplex	Townhouse	Multiplex	Garden Apartment	Mid Rise Apartment	High Rise Apartment	Mobile Home	TOTAL UNITS
915	915.02	167	3	384						554
	915.03	5				164				169
	Census Tract Total	1,611	3	385		164				2,163
916	916.01	1,366		546	580	1				2,493
	Census Tract Total	1,366		546	580	1				2,493
917	917.01	14		613	128	770				1,525
	917.02	5				737				742
	917.03	88								88
	917.04	102	2	297		768				1,169
	Census Tract Total	209	2	910	128	2,275				3,524
918	918.01	1,940		501		1,693				4,134
	Census Tract Total	1,940		501		1,693				4,134
919	919.01	104								104
	919.02	124								124
	919.03	150								150
	919.04	56								56
	919.05	114								114
	919.06	40								40
	919.07	93								93
	919.08	17								17
	919.09	114								114
	919.10	43								43
	919.11	46								46
	919.12	91								91
Census Tract Total	992									992
920	920.01	652								652
	920.02	653	2							655
	920.03	670								670
	Census Tract Total	1,975	2							1,977
921	921.01	82								82
	921.02	127								127

(CONTINUED)

Housing Unit Inventory  
Census and Subcensus Tract  
(January 1995)

Census Tract	Subcensus Tract	Single Family	Duplex	Townhouse	Multiplex	Garden Apartment	Mid Rise Apartment	High Rise Apartment	Mobile Home	TOTAL UNITS
921	921.03	331								331
	921.04	220								220
	921.05	276								276
	921.06	353								353
	921.07	747								747
	<b>Census Tract Total</b>	<b>2,136</b>								
922	922.01	116								116
	922.02	435								435
	922.03	1,738		122						1,860
	922.04	199								199
	922.05	1,014								1,014
	<b>Census Tract Total</b>	<b>3,502</b>			<b>122</b>					
923	923.01	616	46	421						1,083
	<b>Census Tract Total</b>	<b>616</b>	<b>46</b>	<b>421</b>						<b>1,083</b>
924	924.01	307		1,211						1,518
	<b>Census Tract Total</b>	<b>307</b>		<b>1,211</b>						<b>1,518</b>
<b>FAIRFAX COUNTY</b>		<b>170,307</b>	<b>2,270</b>	<b>68,250</b>	<b>6,836</b>	<b>61,697</b>	<b>2,852</b>	<b>13,887</b>	<b>2,052</b>	<b>328,151</b>

Note: Figures exclude group quarters (i.e. Lorton Reformatory, Fort Belvoir, nursing homes and religious quarters).

- 1/ Comprises part of the Town of Vienna (Vienna is composed of Census Tracts 607 through 610).
- 2/ Comprises part of the Town of Herndon (Herndon is composed of Census Tracts 808 and 809).
- 3/ Town of Clifton (Clifton is composed of Census Tract 909).

Market Value of Housing Units 1/, 5/, 6/  
Supervisor District  
(January 1995)

Supervisor District	Unit Type	Under \$80	\$80-\$99	\$100-\$119	\$120-\$139	\$140-\$159	\$160-\$179	\$180-\$199	\$200-\$219	\$220-\$239	\$240-\$259	\$260-\$279	\$280-\$299	\$300-\$349	\$350 & Over	Total Units	
Braddock	Single Family	6	15	55	127	833	2,418	4,620	3,236	3,145	2,031	1,132	647	852	405	19,522	
	Townhouse	3	21	1,021	1,705	2,324	741	326	79	14	1				1	6,236	
	Condominium Apt	1,233	510	510	103												2,356
	Total	1,242	546	1,586	1,935	3,157	3,159	4,946	3,315	3,159	2,032	1,132	647	852	406	28,114	
Dranesville 2/	Single Family	4	10	46	697	1,086	1,339	1,529	1,280	1,282	1,494	1,484	1,350	2,786	9,524	23,911	
	Townhouse	1	72	540	147	39	29	127	128	191	330	232	137	82	356	2,411	
	Condominium Apt	35	69		86	33	25	3								251	
	Total	40	151	586	930	1,158	1,393	1,659	1,408	1,473	1,824	1,716	1,487	2,868	9,880	26,573	
Hunter Mill 3/	Single Family	5	10	86	135	308	654	956	1,270	1,690	1,541	1,555	1,254	1,852	2,705	14,021	
	Townhouse	62	625	1,602	2,131	1,611	999	594	568	347	208	194	74	117	41	9,173	
	Condominium Apt	1,821	1,020	236	138	25	11	14	16	1			1	1		3,284	
	Total	1,888	1,655	1,924	2,404	1,944	1,664	1,564	1,854	2,038	1,749	1,749	1,329	1,970	2,746	26,478	
Lee	Single Family	45	101	355	1,521	3,326	3,743	2,367	1,600	998	537	337	236	317	260	15,743	
	Townhouse	1,304	546	801	2,845	1,981	1,450	1,087	824	351	142	43	21	1		11,396	
	Condominium Apt	1,010	394	464	513	247	4									2,632	
	Total	2,359	1,041	1,620	4,879	5,554	5,197	3,454	2,424	1,349	679	380	257	318	260	29,771	
Mason	Single Family	91	50	142	635	1,975	2,482	1,932	1,655	1,476	1,035	1,097	944	1,361	1,277	16,152	
	Townhouse	65	12	281	536	669	1,114	563	398	231	74	67	50	126	43	4,229	
	Condominium Apt	3,077	1,170	942	454	283	112	42	11	1					1	6,093	
	Total	3,233	1,232	1,365	1,625	2,927	3,708	2,537	2,064	1,708	1,109	1,164	994	1,487	1,321	26,474	

(CONTINUED)

Market Value of Housing Units 1/, 5/, 6/  
Supervisor District  
(January 1995)

Supervisor District	Unit Type	Under \$80	\$80-\$99	\$100-\$119	\$120-\$139	\$140-\$159	\$160-\$179	\$180-\$199	\$200-\$219	\$220-\$239	\$240-\$259	\$260-\$279	\$280-\$299	\$300-\$349	\$350 & Over	Total Units
Mount Vernon	Single Family	190	195	353	754	1,195	1,101	1,185	1,879	1,823	1,382	1,156	904	1,399	1,954	15,470
	Townhouse	409	786	2,600	1,716	645	652	222	59	11	21	62	57	51	1	7,292
	Condominium Apt	951	1,030	277	230	245	126	30	120	93	4	3	3		1	3,113
	Total	1,550	2,011	3,230	2,700	2,085	1,879	1,437	2,058	1,927	1,407	1,221	964	1,450	1,956	25,875
Providence	Single Family	38	45	113	288	1,090	1,635	1,405	1,542	1,591	1,086	916	996	1,610	1,539	13,894
	Townhouse	181	149	443	858	2,186	1,396	1,283	651	356	334	207	189	110	1	8,344
	Condominium Apt	1,745	1,840	1,533	1,114	443	151	103	80	6	27	2			5	7,049
	Total	1,964	2,034	2,089	2,260	3,719	3,182	2,791	2,273	1,953	1,447	1,125	1,185	1,720	1,545	29,287
Springfield 4/	Single Family	47	53	63	110	447	1,540	2,813	3,390	2,789	1,935	1,180	931	2,267	3,696	21,261
	Townhouse	6	416	776	2,692	2,832	1,507	966	363	80	9	32	2		1	9,682
	Condominium Apt	516	306													822
	Total	569	775	839	2,802	3,279	3,047	3,779	3,753	2,869	1,944	1,212	933	2,267	3,697	31,765
Sully	Single Family	80	65	121	330	1,398	2,222	2,661	2,329	2,912	2,880	1,858	1,286	2,340	2,092	22,574
	Townhouse	680	830	2,625	3,748	3,410	1,745	714	292	49	38	11	8	1		14,151
	Condominium Apt	160	491	576	168	56										1,451
	Total	920	1,386	3,322	4,246	4,864	3,967	3,375	2,621	2,961	2,918	1,869	1,294	2,341	2,092	38,176
Town of Clifton	Single Family	2	4	2	5	2	2	4	5	5	9	5	5	6	7	63
	Total	2	4	2	5	2	2	4	5	5	9	5	5	6	7	63
Town of Herndon	Single Family	1	12	24	253	622	599	300	263	209	144	85	45	103	19	2,679

(CONTINUED)

Market Value of Housing Units 1/, 5/, 6/  
Supervisor District  
(January 1995)

Supervisor District	Unit Type	Under \$80	\$80-\$99	\$100-\$119	\$120-\$139	\$140-\$159	\$160-\$179	\$180-\$199	\$200-\$219	\$220-\$239	\$240-\$259	\$260-\$279	\$280-\$299	\$300-\$349	\$350 & Over	Total Units
Town of Herndon	Townhouse	13	533	445	391	339	51		2				1			1,775
	Condominium Apt	311	215	66	124	11										727
	Total	325	760	535	768	972	650	300	265	209	144	85	46	103	19	5,181
Town of Vienna	Single Family	10	28	37	79	220	905	1,080	599	479	325	218	217	160	162	4,519
	Townhouse		8		11	91	60	70	49	71	24	46	11	1		442
	Condominium Apt	100	121													221
	Total	110	157	37	90	311	965	1,150	648	550	349	264	228	161	162	5,182
Fairfax County	Single Family	519	588	1,397	4,934	12,502	18,640	20,852	19,048	18,399	14,399	11,023	8,815	15,053	23,640	169,809
	Townhouse	2,724	3,998	11,134	16,780	16,127	9,744	5,952	3,413	1,701	1,181	894	550	489	444	75,131
	Condominium Apt	10,959	7,166	4,604	2,930	1,343	429	192	227	101	31	5	4	1	7	27,999
	Total	14,202	11,752	17,135	24,644	29,972	28,813	26,996	22,688	20,201	15,611	11,922	9,369	15,543	24,091	272,939

Note: The townhouse category includes townhouses, duplex units and multiplex units. Condominium apartments include new and converted condominium multifamily units.

- 1/ Expressed in thousands of dollars.
- 2/ Excludes the Town of Herndon.
- 3/ Excludes the Town of Vienna.
- 4/ Excludes the Town of Clifton.
- 5/ Market value refers to the estimated value as of January 1995. Market value for each unit is derived from the 1995 tax assessment and is adjusted to reflect the unit's market value, or sales price if the unit sold during 1994.
- 6/ Excludes units in rental complexes, units in nonresidential structures, and units in certain ownership statuses such as cooperatives.



Market Value of Housing Units 1/, 5/, 6/  
Planning District  
(January 1995)

Planning District	Unit Type	Under \$80	\$80-\$99	\$100-\$119	\$120-\$139	\$140-\$159	\$160-\$179	\$180-\$199	\$200-\$219	\$220-\$239	\$240-\$259	\$260-\$279	\$280-\$299	\$300-\$349	\$350 & Over	Total Units
Annandale	Single Family	3	6	70	234	1,093	2,579	3,276	2,030	1,801	1,370	1,121	807	916	467	15,773
	Townhouse	25	8	403	219	906	1,146	379	180	75	2		1	2	7	3,353
	Condominium Apt	1,369	258	322	111	20	1	9	2							2,092
	Total	1,397	272	795	564	2,019	3,726	3,664	2,212	1,876	1,372	1,121	808	918	474	21,218
Baileys	Single Family	66	24	27	89	336	618	562	589	507	306	369	269	539	743	5,044
	Townhouse	41	3	11	174	162	150	54	85	67	31	29	46	18	1	872
	Condominium Apt	2,795	1,016	839	414	263	111	33	9	1					1	5,482
	Total	2,902	1,043	877	677	761	879	649	683	575	337	398	315	557	745	11,398
Bull Run	Single Family	69	56	80	257	1,168	1,918	2,117	1,455	1,600	1,650	1,185	825	1,460	699	14,539
	Townhouse	680	828	2,517	3,217	2,643	1,325	650	291	49	38	11	8	1		12,258
	Condominium Apt	160	491	576	168	56										1,451
	Total	909	1,375	3,173	3,642	3,867	3,243	2,767	1,746	1,649	1,688	1,196	833	1,461	699	28,248
Fairfax	Single Family	13	12	48	73	328	561	707	741	957	674	559	733	1,318	1,590	8,314
	Townhouse	5	17	124	514	845	443	483	233	90	37	1				2,792
	Condominium Apt	392	721	705	298	28										2,144
	Total	410	750	877	885	1,201	1,004	1,190	974	1,047	711	560	733	1,318	1,590	13,250
Jefferson	Single Family	26	24	55	517	1,657	1,980	1,139	897	679	368	253	196	354	283	8,428
	Townhouse	169	13	62	222	443	200	258	170	151	90	73	1			1,852
	Condominium Apt	1,310	556	435	349	80										2,730
	Total	1,505	593	552	1,088	2,180	2,180	1,397	1,067	830	458	326	197	354	283	13,010
Lincolnia	Single Family	21	18	37	58	325	242	175	123	103	93	81	76	93	31	1,476
	Townhouse		2	44	303	161	262	271	104	77	7	6	3	106	35	1,381
	Condominium Apt	124	106	1												231
	Total	145	126	82	361	486	504	446	227	180	100	87	79	199	66	3,088

(CONTINUED)

Market Value of Housing Units 1/, 5/, 6/  
Planning District  
(January 1995)

Planning District	Unit Type	Under \$80	\$80-\$99	\$100-\$119	\$120-\$139	\$140-\$159	\$160-\$179	\$180-\$199	\$200-\$219	\$220-\$239	\$240-\$259	\$260-\$279	\$280-\$299	\$300-\$349	\$350 & Over	Total Units
Lower Potomac	Single Family	92	73	78	99	257	175	116	79	57	38	53	25	57	139	1,338
	Townhouse	252	466	454	570	343	93	5	1							2,184
	Total	344	539	532	669	600	268	121	80	57	38	53	25	57	139	3,522
McLean	Single Family	3	7	32	668	790	586	541	638	850	1,178	1,141	967	2,005	6,848	16,254
	Townhouse	7	92	246	5	12	29	127	128	191	330	232	137	82	355	1,973
	Condominium Apt	96	678	495	583	368	176	106	80	6	27	2			5	2,622
	Total	106	777	773	1,256	1,170	791	774	846	1,047	1,535	1,375	1,104	2,087	7,208	20,849
Mount Vernon	Single Family	85	134	348	1,003	1,420	1,223	1,099	1,781	1,723	1,278	1,038	816	1,202	1,752	14,902
	Townhouse	1,456	690	1,441	1,150	291	168	110	52	10	21	62	57	51	1	5,560
	Condominium Apt	1,778	1,164	277	230	245	126	30	120	93	4	3	3		1	4,074
	Total	3,319	1,988	2,066	2,383	1,956	1,517	1,239	1,953	1,826	1,303	1,103	876	1,253	1,754	24,536
Pohick 2/	Single Family	79	90	134	188	725	1,712	4,187	4,498	3,982	2,756	1,609	1,165	2,484	3,856	27,465
	Townhouse	11	452	2,413	4,632	4,512	1,415	770	356	91	10	1			2	14,665
	Condominium Apt	4	254	188	2											448
	Total	94	796	2,735	4,822	5,237	3,127	4,957	4,854	4,073	2,766	1,610	1,165	2,484	3,858	42,578
Rose Hill	Single Family	18	42	172	733	1,317	1,465	1,363	873	592	349	263	180	242	232	7,841
	Townhouse	1		135	675	1,006	1,319	937	724	268	96	39	4			5,204
	Condominium Apt	93	251	464	513	247	4									1,572
	Total	112	293	771	1,921	2,570	2,788	2,300	1,597	860	445	302	184	242	232	14,617
Springfield	Single Family	13	25	75	380	1,295	2,180	1,268	1,020	858	443	182	79	219	85	8,122
	Townhouse	1	160	578	1,771	1,070	894	629	169	86	46	35	19	1		5,459
	Condominium Apt	606	315													921
	Total	620	500	653	2,151	2,365	3,074	1,897	1,189	944	489	217	98	220	85	14,502

(CONTINUED)

Market Value of Housing Units 1/, 5/, 6/  
Planning District  
(January 1995)

Planning District	Unit Type	Under \$80	\$80-\$99	\$100-\$119	\$120-\$139	\$140-\$159	\$160-\$179	\$180-\$199	\$200-\$219	\$220-\$239	\$240-\$259	\$260-\$279	\$280-\$299	\$300-\$349	\$350 & Over	Total Units
Upper Potomac 3/	Single Family	15	33	155	473	1,418	2,226	2,636	2,797	3,025	2,678	2,054	1,666	2,799	5,313	27,288
	Townhouse	76	1,227	2,425	3,083	2,571	1,413	646	529	343	207	185	59	66	41	12,871
	Condominium Apt	2,132	1,235	302	262	36	11	14	16	1			1	1		4,011
	Total	2,223	2,495	2,882	3,818	4,025	3,650	3,296	3,342	3,369	2,885	2,239	1,726	2,866	5,354	44,170
Vienna 4/	Single Family	16	44	86	162	373	1,175	1,666	1,527	1,665	1,218	1,115	1,011	1,365	1,602	13,025
	Townhouse		40	281	245	1,162	887	633	391	203	266	220	215	162	2	4,707
	Condominium Apt	100	121													221
	Total	116	205	367	407	1,535	2,062	2,299	1,918	1,868	1,484	1,335	1,226	1,527	1,604	17,953
Fairfax County	Single Family	519	588	1,397	4,934	12,502	18,640	20,852	19,048	18,399	14,399	11,023	8,815	15,053	23,640	169,809
	Townhouse	2,724	3,998	11,134	16,780	16,127	9,744	5,952	3,413	1,701	1,181	894	550	489	444	75,131
	Condominium Apt	10,959	7,166	4,604	2,930	1,343	429	192	227	101	31	5	4	1	7	27,999
	Total	14,202	11,752	17,135	24,644	29,972	28,813	26,996	22,688	20,201	15,611	11,922	9,369	15,543	24,091	272,939

Note: The townhouse category includes townhouses, duplex units and multiplex units. Condominium apartments include new and converted condominium multifamily units.

1/ Expressed in thousands of dollars.

2/ Includes the Town of Clifton.

3/ Includes the Town of Herndon.

4/ Includes the Town of Vienna.

5/ Market value refers to the estimated value as of January 1995. Market value for each unit is derived from the 1995 tax assessment and is adjusted to reflect the unit's market value, or sales price if the unit sold during 1994.

6/ Excludes units in rental complexes, units in nonresidential structures, and units in certain ownership statuses such as cooperatives.

# VI. HOUSING UNIT FORECASTS

## HOUSING UNIT FORECASTS

Fairfax County's long-range forecasts of housing units are produced by the Fairfax County Office of Management and Budget. Periodically, the Fairfax County forecasts are developed in conjunction with forecasts of the surrounding jurisdictions under the auspices of the Washington Metropolitan Council of Governments (COG). The COG cooperative forecasts are generated every three to four years. The forecasts contained on the following tables are forecasts that will be submitted for inclusion in the 1996 Round 5.3 COG regional forecast.

### Methodology

The forecasts of housing units in Fairfax County are developed using two data bases from the Urban Development Information System (UDIS): the Parcel File (1983-1995); and the Residential Development File. Parcel Files from previous years provide data on trends in dwelling unit additions to the dwelling unit inventories of areas within the County. The 1995 Parcel File also provides vacant and underutilized land information and planned land use data for the buildout calculations (see Section X). The Residential Development File provides the number of dwelling units, in their respective stages of development, that are expected to be completed in the future (see Section VII). Overall County housing unit forecasts are first prepared based on the total number of units in the development pipeline and the County's total residential capacity. These overall County forecasts are then distributed among areas within the County according to the specific location of projects and the planned densities of these areas.

### 1995 - 2010

The sum of the housing unit forecasts for areas within Fairfax County is controlled by the County's overall forecasts. However, between 1995 and 2010 the small area forecasts are impacted directly by the Comprehensive Plan's residential capacity, recent rates of growth in dwelling units, and the distribution of units within the residential development process.

Active residential development projects are the primary influence on short-term projections. Housing units in the County's development

process are expected to be built before those units planned for vacant land that are not presently involved in development activity. Furthermore, units in the County's development process are expected to be completed according to their stage within the process. That is, units with building permits will be built before units that are in the plan review stage, and units in plan review will be built before units in the rezoning stage. Also, units that are in the fastest growing areas will be built faster than units in other parts of the County.

### 2010 - 2020

After the units in the development process have been forecasted to be completed, an area has either reached buildout or has additional capacity remaining on vacant or underutilized land. Additional capacity is forecasted to be completed based on growth trends and the level of development process activity that has occurred.

The County is expected to reach its present housing unit capacity between 2005 and 2010 (see Section X for data on the current residential capacity of Fairfax County's Comprehensive Plan). However, development does not stop when capacity is reached. Redevelopment, conversion of land uses, and more intense land uses allow for housing development to continue beyond the capacity of the present plan. However, the areas that will be redeveloped and the extent of redevelopment are unknown. Consequently, the forecasts for the year 2020 assume that redevelopment occurs throughout the County in proportion to the area's present Plan capacity.

### Tables

The tables provided in this section show the County's total housing inventory increasing from 130,817 units in 1970 to 215,646 units in 1980 based on 1970 and 1980 Census information, respectively. Between 1980 and 1995, the County's housing inventory has increased by 112,505 units, from 215,646 in 1980 to 328,151 in 1995. By the year 2000, the County is projected to have 352,680 units, an increase of 24,529 units over the County's 1995 housing inventory. By 2020, the County's housing inventory will have increased by 130,063 units

over the 1995 inventory, representing a 39.6 percent increase.

Housing unit forecasts have been prepared for each of the County's supervisor districts. It should be noted that supervisor district boundaries are constitutionally mandated to be reviewed (and possibly changed) every ten years. The forecasts presented in these tables reflect the district boundaries as of July 1991.

As shown in Table 6.1, between 1995 and 2020, the Sully Supervisor District is projected to add nearly 27,500 units to its inventory, the Lee District will add more than 26,200 units, and the Hunter Mill District will add more than 19,800 units. Together, the Sully, Lee, and Hunter Mill Districts will account for over 56.6 percent of the housing unit growth expected in the County between 1995 and 2020.

TABLE 6.1

Housing Unit Change  
by Supervisor District  
1995 - 2020

Supervisor District	Unit Change 1995 - 2020	Percent of Total Change
Braddock	4,832	3.7%
Dranesville	10,692	8.2
Hunter Mill	19,843	15.3
Lee	26,240	20.2
Mason	8,272	6.4
Mount Vernon	8,604	6.6
Providence	17,355	13.3
Springfield	6,744	5.2
Sully	27,482	21.1
Fairfax County	130,063	100.0%

Between 1995 and 2020, all areas of the County are forecasted to experience increases in housing units. As shown in Table 6.2, Bull Run and Upper Potomac planning districts will have the largest increases in their housing inventories. The Lincolnia, Annandale and Lower Potomac planning districts will have the smallest gains in their inventories.

TABLE 6.2

Housing Unit Change  
by Planning District  
1995 - 2020

Planning District	Unit Change 1995 - 2020	Percent of Total Change
Annandale	2,475	1.9%
Baileys	5,436	4.2
Bull Run	23,271	17.9
Fairfax	7,228	5.6
Jefferson	3,764	2.9
Lincolnia	2,132	1.6
Lower Potomac	4,623	3.6
McLean	6,621	5.1
Mount Vernon	9,250	7.1
Pohick	9,644	7.4
Rose Hill	9,568	7.4
Springfield	10,960	8.4
Upper Potomac	28,372	21.8
Vienna	6,718	5.2
Fairfax County	130,063	100.0%

Estimated and Forecasted Housing Units  
Supervisor District  
(January 1995)

Supervisor District	1995	2000	2005	2010	2015	2020
Braddock	30,814	30,949	32,095	33,193	34,343	35,646
Dranesville 1/	34,195	36,859	38,789	40,595	42,570	44,887
Hunter Mill 2/	37,128	41,459	44,670	48,247	52,207	56,971
Lee	38,157	44,156	48,682	53,622	58,840	64,397
Mason	36,988	37,741	39,301	41,045	42,968	45,260
Mount Vernon	32,867	34,485	36,053	37,677	39,424	41,471
Providence	40,626	42,621	45,699	49,242	53,196	57,981
Springfield 3/	32,836	34,197	35,568	36,810	38,109	39,580
Sully	44,540	50,213	54,800	59,833	65,376	72,022
Fairfax County	328,151	352,680	375,656	400,262	427,033	458,214

Estimated and Forecasted Housing Units  
Towns  
(January 1995)

Town	1995	2000	2005	2010	2015	2020
Town of Clifton	68	69	71	72	73	74
Town of Herndon	6,360	7,176	8,083	9,121	10,279	11,680
Town of Vienna	5,510	5,561	5,657	5,709	5,762	5,815
Towns Total	11,938	12,806	13,811	14,902	16,114	17,570

Source: Fairfax County Office of Management and Budget

- 1/ Includes the Town of Herndon.
- 2/ Includes the Town of Vienna.
- 3/ Includes the Town of Clifton.

Historical, Estimated and Forecasted Housing Units  
 Planning District  
 (January 1995)

Planning District	1970	1980	1990	1995	2000	2005	2010	2015	2020
Annandale	17,413	23,600	24,901	25,157	25,304	25,852	26,392	26,969	27,632
Baileys	10,770	13,963	16,573	16,931	17,259	18,246	19,423	20,752	22,367
Bull Run	3,927	7,705	24,559	33,117	37,434	41,329	45,720	50,562	56,388
Fairfax	6,783	11,838	17,181	18,854	20,178	21,437	22,791	24,289	26,082
Jefferson	12,587	15,033	17,365	18,362	18,504	19,223	20,056	20,992	22,126
Lincolnia	3,592	4,128	5,464	5,571	5,862	6,256	6,693	7,160	7,703
Lower Potomac	3,350	3,968	3,936	4,997	5,949	6,664	7,522	8,471	9,620
McLean	13,307	19,874	23,601	24,068	25,563	26,686	27,845	29,139	30,689
Mount Vernon	23,565	31,491	35,338	36,009	36,627	38,476	40,472	42,661	45,259
Pohick 1/	3,884	22,547	41,032	43,736	45,367	47,403	49,269	51,203	53,380
Rose Hill	5,979	7,591	13,524	16,267	17,994	19,579	21,410	23,420	25,835
Springfield	8,914	11,432	14,590	15,239	19,319	21,204	23,035	24,807	26,199
Upper Potomac 2/	6,239	25,702	44,898	49,909	56,174	60,906	65,974	71,574	78,281
Vienna 3/	10,507	16,774	19,502	19,934	21,146	22,396	23,660	25,033	26,652
Fairfax County	130,817	215,646	302,464	328,151	352,680	375,656	400,262	427,033	458,214

Sources: U.S. Bureau of the Census, U.S. Census of Population and Housing: 1970, 1980.  
 Fairfax County Office of Management and Budget: 1990 through 2020.

- 1/ Includes the Town of Clifton.
- 2/ Includes the Town of Herndon.
- 3/ Includes the Town of Vienna.



Estimated and Forecasted Housing Units  
Census and Subcensus Tract  
(January 1995)

Census Tract	Subcensus Tract	1995	2000	2005	2010	2015	2020
151	151.01	477	494	504	510	517	524
	151.02	515	515	521	523	526	529
	151.03	307	312	316	318	321	323
	Census Tract Total	1,299	1,321	1,340	1,352	1,364	1,376
152	152.01	333	348	352	354	356	359
	152.02	1,492	1,492	1,519	1,548	1,579	1,612
	152.03	117	117	117	117	117	117
	152.04						
	Census Tract Total	1,942	1,957	1,988	2,020	2,052	2,088
153	153.01	282	301	310	315	320	325
	153.02	620	621	623	624	625	626
	153.03	471	471	471	471	471	471
	153.04	100	100	100	100	100	100
	Census Tract Total	1,473	1,493	1,504	1,510	1,516	1,522
154	154.01	2,428	2,440	2,492	2,535	2,579	2,627
	154.02	407	409	416	420	424	428
	154.03	405	430	482	544	611	690
	Census Tract Total	3,240	3,279	3,390	3,499	3,614	3,745
155	155.01	1,177	1,179	1,295	1,427	1,571	1,744
	155.02	688	689	694	696	699	701
	155.03	265	268	272	275	277	279
	155.04	90	90	90	90	90	91
	Census Tract Total	2,220	2,226	2,352	2,488	2,637	2,816
156	156.01	548	552	556	558	560	562
	156.02	79	91	91	92	92	92
	156.03	293	308	318	323	328	333
	156.04	116	146	153	157	161	165
	Census Tract Total	1,036	1,097	1,118	1,129	1,141	1,152
157	157.01	432	447	450	452	454	455
	157.02	747	750	761	767	772	778
	157.03	193	194	194	195	195	195

(CONTINUED)

Estimated and Forecasted Housing Units  
Census and Subcensus Tract  
(January 1995)

Census Tract	Subcensus Tract	1995	2000	2005	2010	2015	2020
157	Census Tract Total	1,372	1,391	1,405	1,413	1,421	1,429
158	158.01	668	676	705	720	737	753
	158.02	530	533	546	553	560	568
	158.03	462	465	484	494	505	515
	Census Tract Total	1,660	1,674	1,735	1,768	1,801	1,836
159	159.01	851	885	914	929	945	962
	159.02	190	211	216	219	222	225
	159.03						
	159.04	125	139	141	141	142	143
	Census Tract Total	1,166	1,235	1,271	1,290	1,310	1,330
160	160.01	282	294	322	353	387	430
	160.02	996	997	1,042	1,093	1,148	1,215
	160.03	296	301	305	308	310	312
	Census Tract Total	1,574	1,592	1,669	1,753	1,846	1,957
161	161.01	186	188	195	198	202	206
	161.02	97	97	97	98	98	98
	161.03	624	634	661	676	691	707
	161.04	461	481	504	516	529	542
	Census Tract Total	1,368	1,400	1,457	1,488	1,521	1,553
162 /1	162.01						
	162.02						
	Census Tract Total						
163	163.01	249	317	332	340	348	356
	163.02	469	564	583	593	603	614
	Census Tract Total	718	881	914	932	951	970
201	201.01	436	436	436	436	436	436
	201.02	607	615	641	657	674	690
	Census Tract Total	1,043	1,051	1,077	1,094	1,110	1,127
202	202.01	1,222	1,655	1,951	2,301	2,686	3,152
	202.02	848	941	1,052	1,176	1,313	1,478
	Census Tract Total	2,070	2,596	3,002	3,477	4,000	4,630

(CONTINUED)

Estimated and Forecasted Housing Units  
Census and Subcensus Tract  
(January 1995)

Census Tract	Subcensus Tract	1995	2000	2005	2010	2015	2020
203	203.01	638	645	656	662	668	674
	203.02	672	674	686	692	699	706
	203.03	242	308	324	345	367	394
	203.04	290	407	465	529	600	686
	Census Tract Total	1,842	2,034	2,131	2,228	2,334	2,459
204	204.01	1,586	1,586	1,612	1,640	1,668	1,697
	Census Tract Total	1,586	1,586	1,612	1,640	1,668	1,697
205	205.01	3,122	3,122	3,201	3,290	3,382	3,483
	205.02	179	179	180	180	180	180
	Census Tract Total	3,301	3,301	3,381	3,470	3,562	3,663
206	206.01	180	181	181	181	181	181
	206.02	427	462	532	615	702	803
	206.03	1,051	1,065	1,104	1,141	1,180	1,222
	Census Tract Total	1,658	1,708	1,817	1,938	2,063	2,206
207	207.01	625	661	671	676	682	687
	207.02	129	133	137	140	142	144
	207.03	548	560	573	579	586	593
	Census Tract Total	1,302	1,354	1,381	1,395	1,410	1,425
208	208.01	335	346	352	355	359	362
	208.02	265	265	268	270	272	274
	208.03	554	556	573	582	592	601
	Census Tract Total	1,154	1,167	1,194	1,208	1,223	1,238
210	210.01	280	644	745	861	989	1,142
	210.02	644	723	877	1,068	1,279	1,534
	210.03	242	1,402	1,569	1,747	1,941	2,174
	210.04	287	287	287	287	288	288
	Census Tract Total	1,453	3,056	3,478	3,963	4,496	5,138
211	211.01	2,104	2,835	3,271	3,772	4,318	4,971
	211.02	1,493	2,070	2,358	2,703	3,084	3,545
	211.03	192	192	192	193	193	193
	Census Tract Total	3,789	5,097	5,821	6,668	7,594	8,709

(CONTINUED)

Estimated and Forecasted Housing Units  
Census and Subcensus Tract  
(January 1995)

Census Tract	Subcensus Tract	1995	2000	2005	2010	2015	2020
212	212.01	691	691	692	692	692	693
	Census Tract Total	691	691	692	692	692	693
213	213.01	1,351	1,368	1,377	1,386	1,393	1,401
	213.02	104	104	104	104	104	104
	Census Tract Total	1,455	1,472	1,481	1,490	1,497	1,505
214	214.01	928	930	931	932	932	933
	214.02	1,502	1,514	1,676	1,875	2,102	2,378
	Census Tract Total	2,430	2,444	2,608	2,807	3,034	3,312
215	215.01	1,982	2,096	2,281	2,472	2,689	2,951
	Census Tract Total	1,982	2,096	2,281	2,472	2,689	2,951
216	216.01	1,421	1,421	1,421	1,421	1,421	1,421
	216.02	537	537	589	652	721	802
	Census Tract Total	1,958	1,958	2,010	2,073	2,142	2,223
217	217.01	2,679	2,728	3,058	3,464	3,916	4,466
	Census Tract Total	2,679	2,728	3,058	3,464	3,916	4,466
218	218.01	2,065	2,141	2,480	2,897	3,366	3,940
	Census Tract Total	2,065	2,141	2,480	2,897	3,366	3,940
219 /1	219.01						
	Census Tract Total						
220	220.01	1	1	1	1	1	1
	220.02						
	220.03	492	624	706	807	917	1,050
	220.04	10	10	10	10	10	10
	220.05	227	227	227	227	227	227
	Census Tract Total	730	862	944	1,045	1,155	1,288
221	221.01	1,831	1,835	1,993	2,187	2,402	2,662
	221.02	1	1	1	1	1	1
	221.03	409	986	1,172	1,402	1,659	1,973
	221.04	952	1,020	1,261	1,559	1,889	2,291
	221.05	319	319	332	348	366	388
	221.06	38	38	39	39	40	40

(CONTINUED)

Estimated and Forecasted Housing Units  
Census and Subcensus Tract  
(January 1995)

Census Tract	Subcensus Tract	1995	2000	2005	2010	2015	2020
221	Census Tract Total	3,550	4,199	4,798	5,538	6,357	7,355
222 /2	222.01						
	Census Tract Total						
223	223.01	2,519	2,775	3,054	3,381	3,739	4,164
	Census Tract Total	2,519	2,775	3,054	3,381	3,739	4,164
224	224.01	3,272	3,366	3,814	4,362	4,966	5,700
	224.02	469	469	472	474	476	478
	Census Tract Total	3,741	3,835	4,286	4,836	5,442	6,177
301	301.01	465	468	474	478	481	485
	301.02	1,056	1,056	1,083	1,098	1,113	1,128
	301.03	981	983	1,150	1,351	1,573	1,842
	Census Tract Total	2,502	2,507	2,708	2,927	3,167	3,455
302	302.01	3,850	3,865	4,125	4,348	4,569	4,806
	Census Tract Total	3,850	3,865	4,125	4,348	4,569	4,806
304	304.01	1,468	1,468	1,468	1,469	1,469	1,469
	304.02	855	855	855	855	855	855
	Census Tract Total	2,323	2,323	2,324	2,324	2,324	2,324
305	305.01	567	569	571	573	574	575
	Census Tract Total	567	569	571	573	574	575
306	306.01	551	551	557	564	570	578
	306.02	350	350	350	350	350	350
	306.03	477	477	477	477	477	477
	306.04	435	435	435	436	436	436
	Census Tract Total	1,813	1,813	1,820	1,827	1,834	1,841
307	307.01	217	217	217	217	217	217
	307.02	338	338	338	338	338	338
	307.03	373	373	374	374	375	375
	Census Tract Total	928	928	929	930	931	931
308	308.01	3,326	3,326	3,327	3,328	3,328	3,329
	Census Tract Total	3,326	3,326	3,327	3,328	3,328	3,329
309	309.01	2,272	2,370	2,650	2,956	3,281	3,659

(CONTINUED)

Estimated and Forecasted Housing Units  
Census and Subcensus Tract  
(January 1995)

Census Tract	Subcensus Tract	1995	2000	2005	2010	2015	2020
309	Census Tract Total	2,272	2,370	2,650	2,956	3,281	3,659
310	310.01	2,317	2,330	2,469	2,612	2,751	2,899
	Census Tract Total	2,317	2,330	2,469	2,612	2,751	2,899
313	313.01	1,393	1,394	1,416	1,428	1,440	1,452
	Census Tract Total	1,393	1,394	1,416	1,428	1,440	1,452
314	314.01	1,300	1,301	1,429	1,583	1,752	1,955
	Census Tract Total	1,300	1,301	1,429	1,583	1,752	1,955
315	315.01	1,990	1,997	2,033	2,062	2,089	2,117
	Census Tract Total	1,990	1,997	2,033	2,062	2,089	2,117
316	316.01	784	807	836	858	880	903
	316.02	856	863	883	899	915	932
	316.03	3	1,703	2,603	3,353	3,953	3,953
	Census Tract Total	1,643	3,373	4,322	5,111	5,748	5,788
318	318.01	2,434	2,440	2,554	2,663	2,766	2,873
	Census Tract Total	2,434	2,440	2,554	2,663	2,766	2,873
319	319.01	1,049	1,053	1,056	1,057	1,059	1,060
	Census Tract Total	1,049	1,053	1,056	1,057	1,059	1,060
320	320.01	1,109	1,109	1,116	1,123	1,129	1,136
	Census Tract Total	1,109	1,109	1,116	1,123	1,129	1,136
321	321.01	1,444	1,444	1,464	1,482	1,498	1,515
	Census Tract Total	1,444	1,444	1,464	1,482	1,498	1,515
322	322.01	2,563	2,563	2,609	2,651	2,689	2,729
	Census Tract Total	2,563	2,563	2,609	2,651	2,689	2,729
323	323.01	1,113	1,117	1,118	1,118	1,119	1,119
	323.02	481	547	560	567	574	581
	Census Tract Total	1,594	1,664	1,678	1,685	1,693	1,701
324	324.01	2,625	2,626	2,680	2,715	2,750	2,785
	Census Tract Total	2,625	2,626	2,680	2,715	2,750	2,785
325	325.01	1,823	1,847	1,905	1,936	1,969	2,001
	Census Tract Total	1,823	1,847	1,905	1,936	1,969	2,001
326	326.01	1,504	1,507	1,560	1,588	1,618	1,648

(CONTINUED)

Estimated and Forecasted Housing Units  
Census and Subcensus Tract  
(January 1995)

Census Tract	Subcensus Tract	1995	2000	2005	2010	2015	2020
326	Census Tract Total	1,504	1,507	1,560	1,588	1,618	1,648
327	327.01	2,559	2,620	2,883	3,186	3,511	3,897
	Census Tract Total	2,559	2,620	2,883	3,186	3,511	3,897
328	328.01	746	747	753	756	759	762
	Census Tract Total	746	747	753	756	759	762
401	401.01	701	702	709	713	717	721
	401.02	1,020	1,023	1,069	1,094	1,120	1,147
	401.03	989	1,016	1,024	1,027	1,032	1,036
	Census Tract Total	2,710	2,741	2,802	2,835	2,869	2,903
402	402.01	297	298	339	391	450	524
	402.02	2,082	2,083	2,106	2,127	2,147	2,167
	402.03		9	9	9	9	9
	402.04	131	138	142	144	146	148
	Census Tract Total	2,510	2,528	2,596	2,671	2,752	2,849
403	403.01	471	477	483	486	490	493
	403.02	447	449	461	468	474	481
	Census Tract Total	918	926	944	954	964	974
405	405.01	95	101	101	101	102	102
	405.02	434	441	448	451	455	459
	405.03	1,569	1,578	1,647	1,685	1,724	1,764
	405.04						
	Census Tract Total	2,098	2,120	2,197	2,238	2,281	2,325
406	406.01	934	947	991	1,015	1,039	1,065
	Census Tract Total	934	947	991	1,015	1,039	1,065
407	407.01	1,797	1,800	1,807	1,811	1,815	1,819
	407.02	989	1,002	1,014	1,020	1,026	1,032
	Census Tract Total	2,786	2,802	2,821	2,831	2,841	2,851
408	408.01	861	861	863	864	865	866
	408.02	97	99	99	99	99	100
	408.03	437	444	450	454	457	460
	408.04	668	690	723	740	759	778

(CONTINUED)

Estimated and Forecasted Housing Units  
Census and Subcensus Tract  
(January 1995)

Census Tract	Subcensus Tract	1995	2000	2005	2010	2015	2020
408	408.05						
	Census Tract Total	2,063	2,094	2,135	2,157	2,180	2,203
501	501.01	1,472	1,475	1,560	1,665	1,781	1,922
	501.02	353	353	353	353	354	354
	501.03	414	414	415	416	416	417
	Census Tract Total	2,239	2,242	2,328	2,434	2,551	2,693
502	502.01	512	512	512	512	512	512
	502.02	243	243	243	243	243	243
	502.03	175	179	181	182	183	184
	502.04	392	392	396	398	400	402
	Census Tract Total	1,322	1,326	1,332	1,335	1,338	1,341
503	503.01	304	305	307	308	308	309
	503.02	294	294	294	294	294	294
	503.03	849	868	874	877	881	884
	503.04	227	246	250	251	253	255
	Census Tract Total	1,674	1,713	1,724	1,730	1,737	1,743
504	504.01	371	375	381	386	391	395
	504.02	338	338	339	340	340	341
	504.03	229	234	237	239	240	242
	Census Tract Total	938	947	957	964	971	978
505	505.01	360	360	360	360	361	361
	505.02	303	303	304	305	305	306
	505.03	224	230	231	231	231	232
	Census Tract Total	887	893	895	896	897	898
506	506.01	191	191	197	200	203	206
	506.02	1,677	1,691	1,719	1,749	1,779	1,813
	506.03	298	298	299	299	299	300
	506.04	190	190	190	190	190	190
	506.05	257	267	269	270	272	273
	506.06	375	375	377	378	379	380
	506.07	174	175	176	177	177	178

(CONTINUED)



Estimated and Forecasted Housing Units  
Census and Subcensus Tract  
(January 1995)

Census Tract	Subcensus Tract	1995	2000	2005	2010	2015	2020
506	Census Tract Total	3,162	3,187	3,226	3,263	3,300	3,339
507	507.01	965	975	987	993	999	1,005
	507.02	1,432	1,451	1,458	1,462	1,466	1,470
	Census Tract Total	2,397	2,426	2,445	2,455	2,465	2,476
508	508.01	294	294	298	299	301	303
	508.02	451	453	455	456	457	458
	508.03	407	408	411	412	413	415
	Census Tract Total	1,152	1,155	1,163	1,168	1,172	1,176
509	509.01	286	286	289	291	293	294
	509.02	296	296	297	298	299	299
	Census Tract Total	582	582	586	589	591	593
510	510.01	410	411	411	411	411	411
	510.02	492	494	497	499	500	502
	Census Tract Total	902	905	908	910	912	914
511	511.01	360	365	365	365	365	366
	511.02	451	454	455	456	457	457
	Census Tract Total	811	819	821	821	822	823
512	512.01	226	226	226	227	227	227
	512.02	308	309	310	310	311	311
	512.03	99	99	100	101	102	102
	Census Tract Total	633	634	636	638	639	640
513	513.01	431	451	464	471	477	485
	513.02	447	451	452	452	453	453
	Census Tract Total	878	902	915	923	930	938
514	514.01	204	204	204	204	204	204
	514.02	724	724	724	724	724	724
	514.03	327	327	330	333	336	339
	Census Tract Total	1,255	1,255	1,258	1,261	1,264	1,267
515	515.01	982	982	982	982	982	982
	515.02	1,273	1,294	1,417	1,566	1,737	1,948
	515.03	761	769	778	785	791	798

(CONTINUED)

Estimated and Forecasted Housing Units  
Census and Subcensus Tract  
(January 1995)

Census Tract	Subcensus Tract	1995	2000	2005	2010	2015	2020
515	515.04	981	986	1,024	1,066	1,111	1,161
	Census Tract Total	3,997	4,031	4,200	4,399	4,621	4,889
516	516.01	831	874	977	1,104	1,246	1,417
	516.02	80	80	80	80	80	80
	516.03	790	790	790	790	790	790
	516.04	610	624	625	626	627	627
	516.05	411	413	414	415	415	416
	Census Tract Total	2,722	2,781	2,887	3,015	3,158	3,331
518	518.01	465	467	468	469	470	471
	518.02	173	181	184	185	187	188
	518.03	426	433	440	443	447	450
	Census Tract Total	1,064	1,081	1,092	1,098	1,103	1,109
519	519.01	2,209	2,229	2,509	2,825	3,159	3,548
	Census Tract Total	2,209	2,229	2,509	2,825	3,159	3,548
520	520.01	1,123	1,132	1,151	1,161	1,171	1,182
	Census Tract Total	1,123	1,132	1,151	1,161	1,171	1,182
521	521.01	119	120	120	120	121	121
	521.02	931	934	960	984	1,007	1,032
	521.03	545	546	560	572	582	594
	521.04	618	630	633	635	637	638
	521.05	386	389	396	402	408	414
	Census Tract Total	2,599	2,619	2,670	2,713	2,755	2,798
522	522.01	1,438	1,438	1,439	1,439	1,439	1,440
	522.02	383	383	384	385	385	386
	522.03	352	352	352	352	353	353
	Census Tract Total	2,173	2,173	2,175	2,176	2,177	2,178
523	523.01	3,139	3,139	3,474	3,875	4,315	4,838
	Census Tract Total	3,139	3,139	3,474	3,875	4,315	4,838
524	524.01	507	507	507	507	507	507
	524.02	345	345	345	345	345	345
	524.03	284	290	291	291	291	292

(CONTINUED)

Estimated and Forecasted Housing Units  
Census and Subcensus Tract  
(January 1995)

Census Tract	Subcensus Tract	1995	2000	2005	2010	2015	2020
524	524.04	738	738	739	740	741	741
	524.05	469	484	503	521	538	555
	Census Tract Total	2,343	2,364	2,385	2,404	2,422	2,441
525	525.01	286	286	286	286	286	286
	525.02	386	391	400	405	410	415
	525.03	347	351	354	356	358	360
	525.04	1,553	1,656	1,686	1,710	1,733	1,757
	Census Tract Total	2,572	2,684	2,727	2,757	2,787	2,819
526	526.01	731	750	753	755	756	758
	526.02	461	462	462	462	462	462
	526.03	270	414	491	586	691	818
	Census Tract Total	1,462	1,626	1,706	1,803	1,909	2,038
527	527.01	1,722	1,840	2,029	2,252	2,496	2,784
	Census Tract Total	1,722	1,840	2,029	2,252	2,496	2,784
528	528.01	3,849	3,916	4,407	5,016	5,718	6,586
	Census Tract Total	3,849	3,916	4,407	5,016	5,718	6,586
601	601.01	338	341	345	348	350	353
	601.02	658	665	683	692	702	712
	601.03	261	274	287	294	301	309
	Census Tract Total	1,257	1,280	1,315	1,334	1,354	1,373
602	602.01	489	548	566	576	586	596
	602.02	62	74	76	77	79	80
	602.03	644	644	656	662	668	674
	Census Tract Total	1,195	1,266	1,298	1,315	1,332	1,350
603	603.01	241	256	268	275	282	288
	603.02	660	667	694	708	723	738
	Census Tract Total	901	923	962	983	1,005	1,027
604	604.01	235	262	272	277	283	288
	604.02	1,087	1,220	1,303	1,401	1,509	1,639
	604.03	151	158	162	164	166	168
	Census Tract Total	1,473	1,640	1,737	1,842	1,957	2,095

(CONTINUED)

Estimated and Forecasted Housing Units  
Census and Subcensus Tract  
(January 1995)

Census Tract	Subcensus Tract	1995	2000	2005	2010	2015	2020
605	605.01	642	871	945	1,014	1,089	1,176
	605.02	677	720	743	761	777	794
	605.03	297	315	320	323	326	328
	605.04	209	217	220	224	227	230
	605.05	566	608	622	630	639	648
	Census Tract Total	2,391	2,731	2,850	2,951	3,057	3,176
606	606.01	147	149	151	152	153	154
	606.02	1,103	1,137	1,174	1,194	1,214	1,234
	Census Tract Total	1,250	1,286	1,324	1,345	1,367	1,388
607 /3	607.01	2,695	2,707	2,771	2,806	2,842	2,878
	Census Tract Total	2,695	2,707	2,771	2,806	2,842	2,878
608 /3	608.01	1,123	1,151	1,161	1,166	1,172	1,177
	Census Tract Total	1,123	1,151	1,161	1,166	1,172	1,177
609 /3	609.01	859	870	882	888	895	901
	Census Tract Total	859	870	882	888	895	901
610 /3	610.01	833	833	843	848	853	859
	Census Tract Total	833	833	843	848	853	859
611	611.01	640	645	665	676	687	698
	611.02	1,760	1,888	1,964	2,022	2,081	2,145
	Census Tract Total	2,400	2,533	2,629	2,698	2,768	2,843
612	612.01	194	226	230	232	235	237
	612.02	1,014	1,203	1,253	1,280	1,308	1,337
	612.03	70	71	73	74	75	76
	612.04	10	297	352	419	495	588
	Census Tract Total	1,288	1,797	1,907	2,006	2,113	2,238
615	615.01	224	298	312	320	328	336
	615.02	270	270	273	275	277	279
	615.03	448	479	493	507	520	533
	615.04	623	705	871	1,078	1,306	1,584
	615.05	89	89	89	89	89	89
	Census Tract Total	1,654	1,841	2,039	2,269	2,520	2,821

(CONTINUED)

Estimated and Forecasted Housing Units  
Census and Subcensus Tract  
(January 1995)

Census Tract	Subcensus Tract	1995	2000	2005	2010	2015	2020
616	616.01	672	672	806	971	1,153	1,374
	616.02	353	362	377	387	397	408
	616.04	792	792	901	1,038	1,195	1,390
	616.05	362	363	378	393	407	422
	616.06	2	2	2	2	2	2
	Census Tract Total		2,181	2,191	2,464	2,791	3,155
617	617.01	1,839	2,090	2,468	2,929	3,444	4,073
	617.02	158	176	183	187	192	196
	Census Tract Total	1,997	2,266	2,651	3,116	3,636	4,269
618	618.01	379	379	424	479	542	621
	618.02	2,220	2,226	2,665	3,212	3,825	4,573
	Census Tract Total	2,599	2,605	3,089	3,691	4,367	5,194
619	619.02	1,929	1,929	2,011	2,110	2,221	2,356
	Census Tract Total	1,929	1,929	2,011	2,110	2,221	2,356
701	701.01	281	297	299	301	302	304
	701.02	447	475	483	487	492	496
	701.03	59	64	65	66	67	68
	701.04	169	193	199	203	206	210
	Census Tract Total	956	1,029	1,047	1,057	1,067	1,078
702	702.01	2	2	2	2	2	2
	Census Tract Total	2	2	2	2	2	2
703	703.01	667	683	693	698	704	709
	703.02	127	140	142	143	144	144
	703.03	299	330	338	343	348	352
	Census Tract Total	1,093	1,153	1,173	1,184	1,195	1,206
704	704.01	522	542	557	565	573	582
	704.02	43	45	45	45	45	45
	704.03	358	363	380	390	399	409
	704.04	258	260	266	269	272	275
	704.05	498	498	512	519	526	534
	Census Tract Total	1,679	1,708	1,760	1,788	1,817	1,846

(CONTINUED)

Estimated and Forecasted Housing Units  
Census and Subcensus Tract  
(January 1995)

Census Tract	Subcensus Tract	1995	2000	2005	2010	2015	2020
705	705.01	110	110	112	113	114	115
	705.02	328	328	329	329	329	330
	705.03	712	764	790	806	822	839
	705.04	294	304	306	306	307	308
	705.05	157	186	193	197	201	206
	705.06	503	503	573	660	760	885
	Census Tract Total	2,104	2,195	2,302	2,412	2,535	2,682
706	706.01	179	223	232	236	241	246
	706.02	174	174	176	177	178	179
	706.03	411	411	412	413	414	414
	706.04	171	180	182	183	185	186
	Census Tract Total	935	988	1,002	1,009	1,017	1,025
707	707.01	285	299	302	303	305	307
	707.02	397	404	413	417	422	427
	707.03	280	291	297	299	302	305
	707.04	378	378	378	378	379	379
	707.05	196	241	246	248	251	253
	707.06	257	259	259	259	259	260
	Census Tract Total	1,793	1,872	1,894	1,906	1,918	1,931
708	708.01	272	273	274	274	275	275
	708.02	783	785	788	789	790	792
	Census Tract Total	1,055	1,058	1,062	1,063	1,065	1,067
709	709.01	733	771	786	795	803	812
	709.02	719	731	752	771	789	808
	709.03	255	258	259	259	259	260
	709.04	328	328	392	469	554	658
	709.05	346	348	354	358	361	364
	709.06	105	106	106	106	106	107
	Census Tract Total	2,486	2,542	2,650	2,758	2,874	3,009
710	710.01	58	58	59	59	59	60
	710.02	220	221	224	225	227	228

(CONTINUED)

Estimated and Forecasted Housing Units  
Census and Subcensus Tract  
(January 1995)

Census Tract	Subcensus Tract	1995	2000	2005	2010	2015	2020
710	710.03	258	409	430	454	482	517
	Census Tract Total	536	688	712	738	768	804
711	711.01	174	174	174	174	174	174
	711.02	206	206	206	206	206	206
	711.03	267	268	269	270	271	272
	711.04	306	307	307	308	308	308
	711.05	245	245	245	245	245	246
	711.06	675	675	675	675	675	675
	711.07	190	190	190	191	191	191
	711.08	367	368	378	383	388	394
	Census Tract Total	2,430	2,433	2,445	2,452	2,458	2,465
712	712.01	1	1	1	1	1	1
	712.02						
	712.03	222	236	236	237	237	237
	712.04	2,794	2,825	3,161	3,581	4,064	4,662
	Census Tract Total	3,017	3,062	3,399	3,818	4,302	4,900
713	713.01	3,292	3,305	3,643	4,062	4,544	5,140
	713.02	603	609	615	619	622	626
	Census Tract Total	3,895	3,914	4,258	4,681	5,167	5,766
714	714.01	1,679	1,702	1,766	1,826	1,886	1,950
	714.02	893	897	898	899	899	900
	Census Tract Total	2,572	2,599	2,664	2,725	2,785	2,849
801	801.01	373	472	491	501	512	522
	801.02	217	224	230	233	236	239
	801.03	208	266	278	285	292	300
	801.04	260	300	313	320	327	335
	801.05	203	220	225	227	229	232
	Census Tract Total	1,261	1,482	1,537	1,566	1,597	1,628
802	802.01	315	351	368	377	386	396
	802.02	448	465	476	481	487	493
	802.03	512	520	536	544	553	562

(CONTINUED)

Estimated and Forecasted Housing Units  
Census and Subcensus Tract  
(January 1995)

Census Tract	Subcensus Tract	1995	2000	2005	2010	2015	2020
802	802.04	2,170	2,743	3,021	3,368	3,760	4,241
	802.05		10	10	10	10	10
	Census Tract Total	3,445	4,089	4,410	4,781	5,196	5,701
803	803.01	856	939	982	1,006	1,030	1,055
	803.02	250	250	253	255	257	258
	803.03	826	993	1,036	1,059	1,083	1,108
	803.04	1	1	1	1	1	1
	Census Tract Total	1,933	2,183	2,272	2,321	2,371	2,422
804	804.01	591	661	691	708	725	742
	804.02	632	760	793	811	830	849
	804.03	369	388	396	401	405	409
	804.04	364	435	450	459	468	476
	804.05	772	816	854	874	895	917
	Census Tract Total	2,728	3,060	3,184	3,252	3,322	3,393
805	805.01	1,691	1,849	1,936	1,984	2,033	2,084
	805.02	1,734	1,819	1,947	2,053	2,168	2,300
	805.03	2,004	2,420	2,796	3,240	3,729	4,320
	Census Tract Total	5,429	6,088	6,679	7,278	7,931	8,704
808 /4	808.01	2,516	2,924	3,302	3,732	4,208	4,782
	Census Tract Total	2,516	2,924	3,302	3,732	4,208	4,782
809 /4	809.01	3,844	4,252	4,781	5,389	6,071	6,899
	Census Tract Total	3,844	4,252	4,781	5,389	6,071	6,899
810	810.01	1,003	1,111	1,197	1,302	1,417	1,557
	Census Tract Total	1,003	1,111	1,197	1,302	1,417	1,557
811	811.01	30	140	167	200	237	281
	811.02	868	2,216	2,628	3,129	3,688	4,369
	811.03	1,061	1,272	1,331	1,364	1,398	1,432
	811.04	1,268	1,299	1,360	1,394	1,429	1,464
	Census Tract Total	3,227	4,927	5,486	6,087	6,751	7,547
812	812.01	2,296	2,362	2,438	2,495	2,552	2,611
	Census Tract Total	2,296	2,362	2,438	2,495	2,552	2,611

(CONTINUED)



Estimated and Forecasted Housing Units  
Census and Subcensus Tract  
(January 1995)

Census Tract	Subcensus Tract	1995	2000	2005	2010	2015	2020
814	814.01	2,682	2,685	2,691	2,694	2,698	2,701
	Census Tract Total	2,682	2,685	2,691	2,694	2,698	2,701
815	815.01	763	775	787	793	799	806
	Census Tract Total	763	775	787	793	799	806
816	816.01	463	484	491	495	499	503
	816.02	557	566	572	574	577	580
	Census Tract Total	1,020	1,050	1,063	1,070	1,077	1,084
817	817.01	547	560	579	589	599	610
	817.02	542	692	725	743	761	780
	817.03	616	624	635	641	647	653
	817.04	1,775	1,877	1,999	2,148	2,311	2,510
	Census Tract Total	3,480	3,753	3,938	4,120	4,319	4,553
819	819.01	1,400	1,487	1,498	1,503	1,509	1,516
	819.02	460	609	635	649	663	678
	Census Tract Total	1,860	2,096	2,132	2,152	2,173	2,194
820	820.01	1,960	2,757	3,184	3,684	4,236	4,902
	820.02	474	474	474	474	474	474
	Census Tract Total	2,434	3,231	3,658	4,158	4,710	5,376
821	821.01	1,490	1,491	1,491	1,491	1,491	1,491
	Census Tract Total	1,490	1,491	1,491	1,491	1,491	1,491
822	822.01	323	576	682	815	964	1,147
	822.02	369	369	369	369	369	369
	822.03	2,060	2,060	2,286	2,568	2,892	3,293
	Census Tract Total	2,752	3,005	3,337	3,752	4,225	4,809
823	823.01	5,504	5,506	6,460	7,647	8,974	10,596
	Census Tract Total	5,504	5,506	6,460	7,647	8,974	10,596
824	824.01	623	857	908	947	990	1,039
	Census Tract Total	623	857	908	947	990	1,039
825	825.01	216	496	555	627	706	804
	825.02	3,755	3,843	3,993	4,076	4,160	4,247
	Census Tract Total	3,971	4,339	4,548	4,702	4,867	5,050

(CONTINUED)

Estimated and Forecasted Housing Units  
Census and Subcensus Tract  
(January 1995)

Census Tract	Subcensus Tract	1995	2000	2005	2010	2015	2020
826	826.01	602	618	646	661	677	693
	826.02	2,719	2,910	3,091	3,268	3,462	3,689
	Census Tract Total	3,321	3,528	3,737	3,930	4,138	4,382
901	901.01	4	4	4	4	4	4
	901.02	12	12	12	12	13	13
	901.03	1,046	1,046	1,059	1,066	1,074	1,081
	901.04	1	1	1	1	1	1
	901.05	2,321	2,327	2,342	2,352	2,361	2,372
	901.06						
	Census Tract Total	3,384	3,390	3,419	3,435	3,453	3,470
905	905.01	1,215	1,237	1,255	1,269	1,283	1,297
	905.02	1,622	1,744	1,817	1,857	1,898	1,940
	Census Tract Total	2,837	2,981	3,072	3,126	3,181	3,237
909 /5	909.01	68	69	71	72	73	74
	Census Tract Total	68	69	71	72	73	74
910	910.01	8	8	8	9	9	9
	910.02	497	499	523	536	549	562
	Census Tract Total	505	507	531	544	558	571
911	911.01	4,224	4,325	4,432	4,490	4,550	4,612
	Census Tract Total	4,224	4,325	4,432	4,490	4,550	4,612
912	912.01	2,094	2,364	2,826	3,398	4,031	4,802
	912.02		613	699	805	929	1,081
	Census Tract Total	2,094	2,977	3,524	4,203	4,960	5,883
913	913.01	22	22	22	22	22	23
	913.02	36	37	37	38	38	38
	913.03	572	911	1,042	1,202	1,383	1,603
	913.04	3,240	4,076	4,810	5,700	6,693	7,901
	Census Tract Total	3,870	5,046	5,911	6,963	8,135	9,565
914	914.01	5,800	6,100	7,006	8,058	9,214	10,607
	Census Tract Total	5,800	6,100	7,006	8,058	9,214	10,607
915	915.01	1,440	1,747	1,863	1,957	2,057	2,171

(CONTINUED)

Estimated and Forecasted Housing Units  
Census and Subcensus Tract  
(January 1995)

Census Tract	Subcensus Tract	1995	2000	2005	2010	2015	2020
915	915.02	554	777	876	984	1,098	1,231
	915.03	169	169	185	205	227	253
	Census Tract Total	2,163	2,693	2,924	3,145	3,382	3,655
916	916.01	2,493	2,518	2,857	3,234	3,646	4,141
	Census Tract Total	2,493	2,518	2,857	3,234	3,646	4,141
917	917.01	1,525	1,845	2,210	2,665	3,173	3,795
	917.02	742	1,125	1,170	1,224	1,286	1,363
	917.03	88	255	272	285	299	315
	917.04	1,169	1,328	1,505	1,718	1,957	2,245
	Census Tract Total	3,524	4,553	5,157	5,892	6,715	7,718
918	918.01	4,134	4,797	5,171	5,572	6,012	6,536
	Census Tract Total	4,134	4,797	5,171	5,572	6,012	6,536
919	919.01	104	114	115	116	117	118
	919.02	124	250	262	268	275	282
	919.03	150	158	161	162	164	165
	919.04	56	65	65	65	66	66
	919.05	114	369	384	392	400	408
	919.06	40	50	50	51	51	51
	919.07	93	128	130	131	132	133
	919.08	17	21	21	21	21	21
	919.09	114	119	120	120	121	121
	919.10	43	44	44	44	44	44
	919.11	46	48	48	48	48	49
	919.12	91	93	93	94	94	94
	Census Tract Total	992	1,459	1,494	1,513	1,532	1,552
920	920.01	652	738	765	781	796	812
	920.02	655	666	688	700	712	724
	920.03	670	721	743	755	767	779
	Census Tract Total	1,977	2,125	2,196	2,235	2,275	2,315
921	921.01	82	87	88	88	88	89
	921.02	127	154	157	158	160	161

(CONTINUED)

Estimated and Forecasted Housing Units  
Census and Subcensus Tract  
(January 1995)

Census Tract	Subcensus Tract	1995	2000	2005	2010	2015	2020
921	921.03	331	370	382	388	395	402
	921.04	220	226	227	228	228	229
	921.05	276	326	341	350	358	367
	921.06	353	369	376	380	384	388
	921.07	747	751	754	756	758	760
	Census Tract Total		2,136	2,283	2,325	2,348	2,372
922	922.01	116	125	127	128	129	129
	922.02	435	458	480	492	504	516
	922.03	1,860	2,088	2,206	2,291	2,381	2,481
	922.04	199	278	288	293	299	304
	922.05	1,014	1,217	1,266	1,292	1,320	1,348
	Census Tract Total		3,624	4,166	4,365	4,495	4,631
923	923.01	1,083	1,097	1,108	1,114	1,120	1,126
	Census Tract Total		1,083	1,097	1,108	1,114	1,120
924	924.01	1,518	1,528	1,543	1,550	1,559	1,567
	Census Tract Total		1,518	1,528	1,543	1,550	1,559
Fairfax County		328,151	352,680	375,656	400,262	427,033	458,214

Source: Fairfax County Office of Management and Budget.

- 1/ Fort Belvoir Military Reservation (Fairfax County does not forecast dwelling units in this Census Tract).
- 2/ Department of Corrections, District of Columbia (Fairfax County does not forecast dwelling units in this Census Tract).
- 3/ Comprises part of the Town of Vienna (Vienna is composed of Census Tracts 607 through 610).
- 4/ Comprises part of the Town of Herndon (Herndon is composed of Census Tracts 808 and 809).
- 5/ Town of Clifton (Clifton is composed of Census Tract 909).

# VII. RESIDENTIAL DEVELOPMENT ACTIVITY

## RESIDENTIAL DEVELOPMENT ACTIVITY

The residential development process encompasses the entire land development process, from the rezoning of land, through the site plan and subdivision phases, the issuance of building permits, and the construction and completion of housing units. The development process reflects active residential projects occurring in the County at one specific point in time (January 1995), and does not reflect cumulative activity occurring throughout the preceding year. Therefore, similar data from January 1994 are compared to the current January 1995 data. A project is considered active if units in that project are being processed in at least one development activity stage, and the units have not remained in that stage for more than four years.

As of January 1995, there were 29,167 units in the residential development process (see Table 7.1). This total represents an increase of 711 units, or 2.5 percent, from the January 1994 total of 28,456. Figure 7.1 presents, in graphical form, the total number of units in the residential development process by type of unit from 1973 to 1995.

The Under Construction stage of the development process showed slightly decreased activity, from 1,784 units in 1994 to 1,736 units in 1995. This was a decrease of 48 units, or 2.7 percent from the 1994 figure. Units Authorized But Not Started increased 56.2 percent from 1,257 units in 1994 to 1,964 units in 1995.

The Site Plan Approved stage showed a decrease of 1,527 units or 17.4 percent, from the 1994 total of 8,797 units to 7,270 units in 1995. Units in the Site Plan Submitted stage increased from 12,480 units in 1994 to 12,495 units in 1995. This was an increase of 15 units, or 0.1 percent.

The Rezoning Granted stage of the development process showed an increase in activity between 1994 and 1995. The number of units in this stage increased from 2,175 units in 1994 to 2,772 units in 1995, an increase of 597 units, or 27.4 percent. The Rezoning Pending stage grew from 1,963 units in 1994 to 2,930 units in 1995, an increase of 967 units or 49.3 percent.

TABLE 7.1

Housing Units in the Development Process  
by Development Stage  
1994 - 1995

Development Stage	Housing Units in the Development Process		
	1994	1995	Percent Change
Under Construction	1,784	1,736	-2.7%
Authorized but Not Started	1,257	1,964	56.2%
Site Plan Approved	8,797	7,270	-17.4%
Site Plan Submitted	12,480	12,495	0.1%
Rezoning Granted	2,175	2,772	27.4%
Rezoning Pending	1,963	2,930	49.3%
<b>Total Residential Development Process</b>	<b>28,456</b>	<b>29,167</b>	<b>2.5%</b>

Table 7.2 shows the number of units in the development process by unit type. The single-family category includes only single-family detached units, while the townhouse category includes townhouses, duplexes, and multiplex units. The multifamily category includes condominium and rental garden, medium-rise, and high-rise apartment units.

Between 1994 and 1995, the number of single-family units decreased by 918 units, or 7.0 percent, while the number of townhouse units in the development process increased by 907 units, or 9.8 percent. During the same time period, the number of multifamily units increased by 11.8 percent, or 722 units.

TABLE 7.2

Housing Units in the Development Process  
By Unit Type, 1994 - 1995

Unit Type	Housing Units		
	1994	1995	Percent Change
Single Family	13,073	12,155	-7.0%
Townhouse	9,256	10,163	9.8%
Multifamily	6,127	6,849	11.8%
<b>Total Residential Development Process</b>	<b>28,456</b>	<b>29,167</b>	<b>2.5%</b>

Figure 7.2 presents the number of residential housing units under development by census tract. Darker areas on the map are indicative of greater numbers of units under development. The majority of development in Fairfax County is occurring in the northern and western areas of the County, with significant development in specific areas of the southern portion of the County. Development in the southern portion is seen in Kingstowne and areas surrounding Lorton (Crosspointe).

Among the supervisor districts, the Sully District had the largest number of units in the development process. The 6,559 units of the Sully District represent 22.5 percent of the County's total residential development activity. The Hunter Mill District ranked second with 6,359 units under development, accounting for 21.8 percent of the County total. The Lee District also had a significant level of development activity, with 4,537 units under development, or 15.6 percent of the County total. The Braddock District showed the least level of development activity with 288 units under development.

The two planning districts located in the northern and western areas of the County, Upper Potomac and Bull Run, accounted for 46.8 percent of the January 1995 residential development activity. Upper Potomac Planning District had the largest number of units in the development process, with a total of 8,528 units. Bull Run Planning District had the second largest amount of residential development activity with 5,123 units. Residential development activity is less evident in other areas of the County, with the least activity occurring in the Jefferson, Annandale, and Baileys Planning Districts.

Figure 7.1

# Housing Units in the Residential Development Process By Structure Type, 1973 to 1995

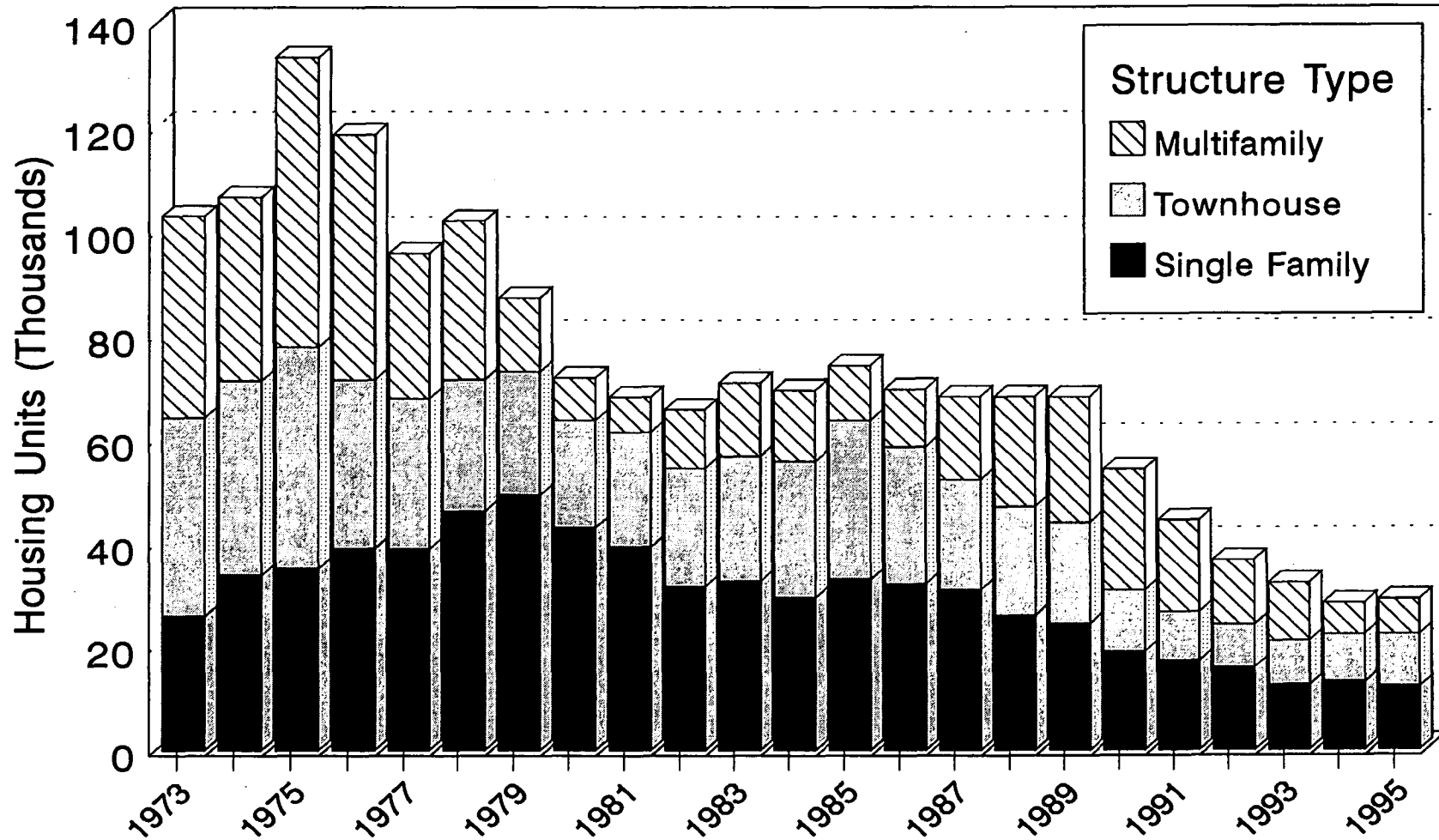

Source: Fairfax County Office of Management and Budget.

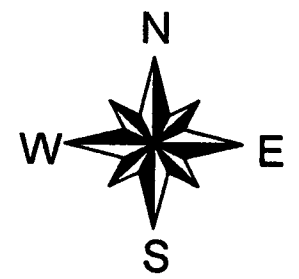

Figure 7.2

# Housing Units in the Development Process

By Subcensus Tract  
January 1995

Fairfax County, Virginia



**Housing Units in the Development Process**

	0 to 9 Units
	10 to 99 Units
	100 to 199 Units
	200 to 892 Units

Major Roads

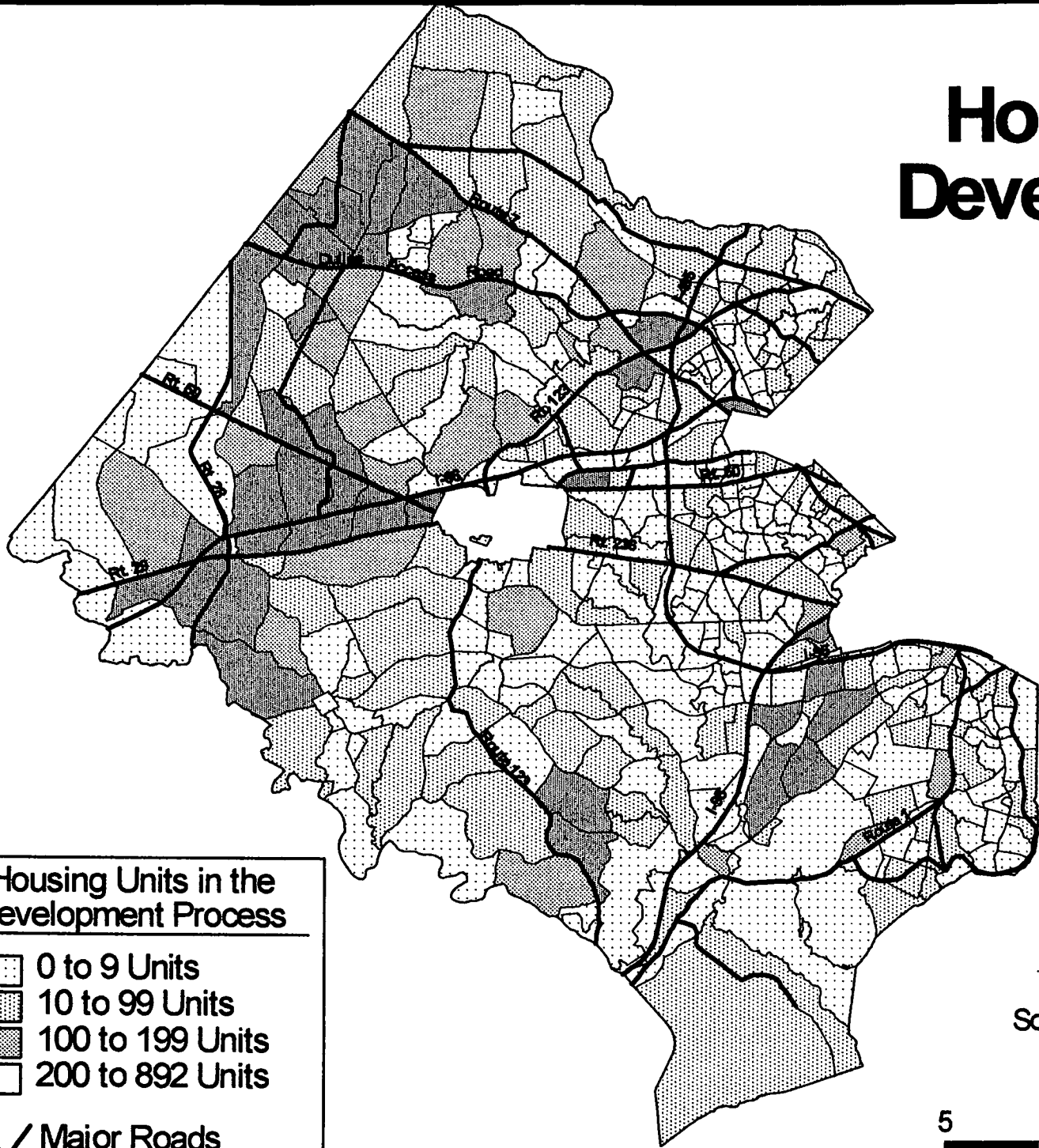

Source: Urban Development Information System,  
Office of Management and Budget



Summary of Residential Development Activity  
Supervisor District  
(January 1995)

Supervisor District	Under Construction				Bldg Permit Issued, No Construction				Site Plan and/or Subdivision Plat Apprvd				Site Plan and/or Subdivision Plat Submtd			
	SF	TH	MF	Total	SF	TH	MF	Total	SF	TH	MF	Total	SF	TH	MF	Total
Braddock	16			16	3			3	74			74	42			42
Dranesville 1/	207	10	113	330	78	10	249	337	967	66	299	1,332	356	123	372	851
Hunter Mill 2/	144	139		283	69	34	106	209	380	198	96	674	428	1,894	1,064	3,386
Lee	39	137		176	16	69	126	211	837	338	18	1,193	826	1,784	144	2,754
Mason	22			22	12		66	78	247	3		250	89	314		403
Mount Vernon	30	77		107	31	1	28	60	569	131	1	701	182	112	594	888
Providence	124	83		207	59	1		60	526	95	1	622	380	639	78	1,097
Springfield 3/	156			156	75			75	720			720	410			410
Sully	170	267	2	439	99	43	789	931	1,070	481	153	1,704	450	1,571	643	2,664
<b>TOTAL</b>	<b>908</b>	<b>713</b>	<b>115</b>	<b>1,736</b>	<b>442</b>	<b>158</b>	<b>1,364</b>	<b>1,964</b>	<b>5,390</b>	<b>1,312</b>	<b>568</b>	<b>7,270</b>	<b>3,163</b>	<b>6,437</b>	<b>2,895</b>	<b>12,495</b>

Town	Under Construction				Bldg Permit Issued, No Construction				Site Plan and/or Subdivision Plat Apprvd				Site Plan and/or Subdivision Plat Submtd			
	SF	TH	MF	Total	SF	TH	MF	Total	SF	TH	MF	Total	SF	TH	MF	Total
Town of Clifton					1			1								
Town of Herndon	16	9	113	138	7	9	240	256	5	56	299	360	2		120	122
Town of Vienna	12	2		14	5			5					32			32
<b>TOWNS TOTAL</b>	<b>28</b>	<b>11</b>	<b>113</b>	<b>152</b>	<b>13</b>	<b>9</b>	<b>240</b>	<b>262</b>	<b>5</b>	<b>56</b>	<b>299</b>	<b>360</b>	<b>34</b>		<b>120</b>	<b>154</b>

Note: All numbers shown in the table refer to housing units. Single Family category includes only single family detached units. Townhouse includes townhouses, duplexes, and multiplex units. Multifamily includes condominium and rental garden, medium-rise and high-rise apartment units.

- 1/ Includes the Town of Herndon.
- 2/ Includes the Town of Vienna.
- 3/ Includes the Town of Clifton.

Summary of Residential Development Activity  
Supervisor District  
(January 1995)

Supervisor District	Rezoning Granted				Rezoning Pending				Total Development Activity			
	SF	TH	MF	Total	SF	TH	MF	Total	SF	TH	MF	Total
Braddock	139			139	14			14	288			288
Dranesville 1/	226		52	278	11	74	67	152	1,845	283	1,152	3,280
Hunter Mill 2/	410	311	328	1,049	179	298	281	758	1,610	2,874	1,875	6,359
Lee	24	37	41	102		101		101	1,742	2,466	329	4,537
Mason	24			24	487	7		494	881	324	66	1,271
Mount Vernon	98	159	491	748	74		16	90	984	480	1,130	2,594
Providence	10	48		58	150	2	631	783	1,249	868	710	2,827
Springfield 3/	27			27	18	46		64	1,406	46		1,452
Sully	91	256		347	270	204		474	2,150	2,822	1,587	6,559
<b>TOTAL</b>	<b>1,049</b>	<b>811</b>	<b>912</b>	<b>2,772</b>	<b>1,203</b>	<b>732</b>	<b>995</b>	<b>2,930</b>	<b>12,155</b>	<b>10,163</b>	<b>6,849</b>	<b>29,167</b>

Town	Rezoning Granted				Rezoning Pending				Total Development Activity			
	SF	TH	MF	Total	SF	TH	MF	Total	SF	TH	MF	Total
Town of Clifton									1			1
Town of Herndon			52	52		18		18	30	92	824	946
Town of Vienna									49	2		51
<b>TOWNS TOTAL</b>			<b>52</b>	<b>52</b>		<b>18</b>		<b>18</b>	<b>80</b>	<b>94</b>	<b>824</b>	<b>998</b>

Note: All numbers shown in the table refer to housing units. Single Family category includes only single family detached units. Townhouse includes townhouses, duplexes, and multiplex units. Multifamily includes condominium and rental garden, medium-rise and high-rise apartment units.

- 1/ Includes the Town of Herndon.
- 2/ Includes the Town of Vienna.
- 3/ Includes the Town of Clifton.

Summary of Residential Development Activity  
Planning District  
(January 1995)

Planning District	Under Construction				Bldg Permit Issued, No Construction				Site Plan and/or Subdivision Plat Apprvd				Site Plan and/or Subdivision Plat Submtd			
	SF	TH	MF	Total	SF	TH	MF	Total	SF	TH	MF	Total	SF	TH	MF	Total
Annandale	23			23	10			10	104			104	10			10
Baileys	6			6	4		66	70	68	1		69	9	174		183
Bull Run	112	231	2	345	74	36	488	598	793	342	36	1,171	186	1,506	509	2,201
Fairfax	47	74		121	24	7	301	332	162	189	117	468	271	65	134	470
Jefferson	16			16	2			2	79			79	31	14		45
Lincolnia	2			2					115	2		117	46	126		172
Lower Potomac	2	64		66	4	1	28	33	162	131	1	294	9	94	594	697
McLean	75	1		76	24	1	9	34	517	10	1	528	147	584	252	983
Mount Vernon	27			27	19		78	97	260	96		356	40	26	144	210
Pohick 1/	163	13		176	76			76	887			887	492			492
Rose Hill	28	85		113	15	31	20	66	231	223	18	472	109	967		1,076
Springfield	9	52		61	8	38	28	74	590	19		609	790	809		1,599
Upper Potomac 2/	298	126	113	537	137	38	346	521	1,017	161	395	1,573	744	1,991	1,184	3,919
Vienna 3/	100	67		167	45	6		51	405	138		543	279	81	78	438
<b>TOTAL</b>	<b>908</b>	<b>713</b>	<b>115</b>	<b>1,736</b>	<b>442</b>	<b>158</b>	<b>1,364</b>	<b>1,964</b>	<b>5,390</b>	<b>1,312</b>	<b>568</b>	<b>7,270</b>	<b>3,163</b>	<b>6,437</b>	<b>2,895</b>	<b>12,495</b>

(CONTINUED)

Note: All numbers shown in the table refer to housing units.

Single Family category includes only single family detached units. Townhouse includes townhouses, duplexes, and multi-plex units. Multifamily includes condominium and rental garden, medium-rise and high-rise apartment units.

- 1/ Includes the Town of Clifton.
- 2/ Includes the Town of Herndon.
- 3/ Includes the Town of Vienna.

Summary of Residential Development Activity  
 Planning District  
 (January 1995)

Planning District	Rezoning Granted				Rezoning Pending				Total Development Activity			
	SF	TH	MF	Total	SF	TH	MF	Total	SF	TH	MF	Total
Annandale	18			18		7		7	165	7		172
Baileys	6			6					93	175	66	334
Bull Run	78	256		334	270	204		474	1,513	2,575	1,035	5,123
Fairfax	3			3	89			89	596	335	552	1,483
Jefferson									128	14		142
Lincolnia					487			487	650	128		778
Lower Potomac		159	491	650			16	16	177	449	1,130	1,756
McLean	2			2	4		698	702	769	596	960	2,325
Mount Vernon			41	41					346	122	263	731
Pohick 1/	261			261	38	46		84	1,917	59		1,976
Rose Hill	19			19		101		101	402	1,407	38	1,847
Springfield	5	37		42	68			68	1,470	955	28	2,453
Upper Potomac 2/	509	307	380	1,196	129	372	281	782	2,834	2,995	2,699	8,528
Vienna 3/	148	52		200	118	2		120	1,095	346	78	1,519
<b>TOTAL</b>	<b>1,049</b>	<b>811</b>	<b>912</b>	<b>2,772</b>	<b>1,203</b>	<b>732</b>	<b>995</b>	<b>2,930</b>	<b>12,155</b>	<b>10,163</b>	<b>6,849</b>	<b>29,167</b>

Note: All numbers shown in the table refer to housing units.

Single Family category includes only single family detached units. Townhouse includes townhouses, duplexes, and multi-plex units. Multifamily includes condominium and rental garden, medium-rise and high-rise apartment units.

- 1/ Includes the Town of Clifton.
- 2/ Includes the Town of Herndon.
- 3/ Includes the Town of Vienna.

Summary of Residential Development Activity  
Census and Subcensus Tract  
(January 1995)

Census Tract	Subcensus Tract	Under Construction	Bldg Permit Issued, No Construction	Site Plan and/or Subdivision Plat Apprvd	Site Plan and/or Subdivision Plat Submtd	Rezoning Granted	Rezoning Pending	Total Development Activity
151	151.01			17				17
	151.03			5				5
	<b>Census Tract Total</b>			22				22
152	152.01		2	13				15
	<b>Census Tract Total</b>		2	13				15
153	153.01			19				19
	153.02			1				1
	<b>Census Tract Total</b>			20				20
154	154.01			1	11			12
	154.02		1	1				2
	154.03		1		24			25
	<b>Census Tract Total</b>		2	2	35			39
155	155.01	1		1				2
	155.02			1				1
	155.03	1		2				3
	<b>Census Tract Total</b>	2		4				6
156	156.01			4				4
	156.02			12				12
	156.03	3		12				15
	156.04	4	3	23				30
	<b>Census Tract Total</b>	7	3	51				61
157	157.01			15				15
	157.02			3				3
	157.03			1				1
	<b>Census Tract Total</b>			19				19
158	158.01			8				8
	158.02	2	1					3
	158.03	1		2				3
	<b>Census Tract Total</b>	3	1	10				14

(CONTINUED)

Summary of Residential Development Activity  
Census and Subcensus Tract  
(January 1995)

Census Tract	Subcensus Tract	Under Construction	Bldg Permit Issued, No Construction	Site Plan and/or Subdivision Plat Apprvd	Site Plan and/or Subdivision Plat Submtd	Rezoning Granted	Rezoning Pending	Total Development Activity
159	159.01	2		9	23			34
	159.02	1		20				21
	159.04		6	8				14
	Census Tract Total	3	6	37	23			69
160	160.01	5	4	3				12
	160.02			1				1
	160.03			5				5
	Census Tract Total	5	4	9				18
161	161.01			2				2
	161.03	2		8				10
	161.04	2	1	17				20
	Census Tract Total	4	1	27				32
162	162.01				8			8
	Census Tract Total				8			8
163	163.01	1	1	66				68
	163.02		3	92				95
	Census Tract Total	1	4	158				163
201	201.02				8			8
	Census Tract Total				8			8
202	202.01	4		26	403			433
	202.02	4	2	83	4			93
	Census Tract Total	8	2	109	407			526
203	203.01			1	6			7
	203.02			2				2
	203.03				66			66
	203.04			1	116			117
	Census Tract Total			4	188			192
206	206.01			1				1
	206.02			35				35

(CONTINUED)

Summary of Residential Development Activity  
Census and Subcensus Tract  
(January 1995)

Census Tract	Subcensus Tract	Under Construction	Bldg Permit Issued, No Construction	Site Plan and/or Subdivision Plat Apprvd	Site Plan and/or Subdivision Plat Submtd	Rezoning Granted	Rezoning Pending	Total Development Activity
206	206.03	3		11				14
	Census Tract Total	3		47				50
207	207.01			5	31			36
	207.02	2	2					4
	207.03			1	11			12
	Census Tract Total	2	2	6	42			52
208	208.01	2	9					11
	208.03			2				2
	Census Tract Total	2	9	2				13
210	210.01	1		3	360			364
	210.02	21		21		37		79
	210.03			2	1,158			1,160
	Census Tract Total	22		26	1,518	37		1,603
211	211.01	33	74	555	69		14	745
	211.02	19	2	210	346			577
	211.03						54	54
	Census Tract Total	52	76	765	415		68	1,376
213	213.01	3		14				17
	Census Tract Total	3		14				17
214	214.01			2				2
	214.02			4	8			12
	Census Tract Total			6	8			14
215	215.01		30	12	144			186
	Census Tract Total		30	12	144			186
216	216.02					5		5
	Census Tract Total					5		5
217	217.01			49				49
	Census Tract Total			49				49
218	218.01		48	28		36		112

(CONTINUED)



Summary of Residential Development Activity  
Census and Subcensus Tract  
(January 1995)

Census Tract	Subcensus Tract	Under Construction	Bldg Permit Issued, No Construction	Site Plan and/or Subdivision Plat Apprvd	Site Plan and/or Subdivision Plat Submtd	Rezoning Granted	Rezoning Pending	Total Development Activity
218	Census Tract Total		48	28		36		112
220	220.03	35	1	1	95			132
	Census Tract Total	35	1	1	95			132
221	221.01	1		3				4
	221.03	20	28	73	594	650	16	1,381
	221.04	9		59				68
	Census Tract Total	30	28	135	594	650	16	1,453
223	223.01	53	43	67	93	19	101	376
	Census Tract Total	53	43	67	93	19	101	376
224	224.01	26	8	60				94
	Census Tract Total	26	8	60				94
301	301.01				3			3
	301.03	2						2
	Census Tract Total	2			3			5
302	302.01	2		3	10	136	14	165
	Census Tract Total	2		3	10	136	14	165
305	305.01			2				2
	Census Tract Total			2				2
309	309.01	4	3	80	11	1		99
	Census Tract Total	4	3	80	11	1		99
310	310.01	2	1	10				13
	Census Tract Total	2	1	10				13
313	313.01			1				1
	Census Tract Total			1				1
314	314.01			1			46	47
	Census Tract Total			1			46	47
315	315.01	1		2	4			7
	Census Tract Total	1		2	4			7
316	316.01	5		18				23

(CONTINUED)

Summary of Residential Development Activity  
Census and Subcensus Tract  
(January 1995)

Census Tract	Subcensus Tract	Under Construction	Bldg Permit Issued, No Construction	Site Plan and/or Subdivision Plat Apprvd	Site Plan and/or Subdivision Plat Submtd	Rezoning Granted	Rezoning Pending	Total Development Activity
316	316.02			7		5		12
	Census Tract Total	5		25		5		35
318	318.01			1	5			6
	Census Tract Total			1	5			6
319	319.01				4			4
	Census Tract Total				4			4
323	323.01	1		3				4
	323.02	9	2	55				66
	Census Tract Total	10	2	58				70
324	324.01	1					18	19
	Census Tract Total	1					18	19
325	325.01	16	8					24
	Census Tract Total	16	8					24
326	326.01	1		2				3
	Census Tract Total	1		2				3
327	327.01	13		48				61
	Census Tract Total	13		48				61
328	328.01			1				1
	Census Tract Total			1				1
401	401.01			1			8	9
	401.02	1		2			81	84
	401.03			3	24			27
	Census Tract Total	1		6	24		89	120
402	402.01			1				1
	402.02			1				1
	402.03				9			9
	402.04			7				7
	Census Tract Total			9	9			18
403	403.01			6				6

(CONTINUED)

Summary of Residential Development Activity  
Census and Subcensus Tract  
(January 1995)

Census Tract	Subcensus Tract	Under Construction	Bldg Permit Issued, No Construction	Site Plan and/or Subdivision Plat Apprvd	Site Plan and/or Subdivision Plat Submtd	Rezoning Granted	Rezoning Pending	Total Development Activity
403	403.02	1		1				2
	Census Tract Total	1		7				8
405	405.01	1		5				6
	405.02			1	6			7
	405.03			1	8	3		12
	Census Tract Total	1		7	14	3		25
406	406.01		1	12				13
	Census Tract Total		1	12				13
407	407.01	1		2				3
	407.02	5	1	7				13
	Census Tract Total	6	1	9				16
408	408.02			2				2
	408.03			7				7
	408.04	3	1	18				22
	Census Tract Total	3	1	27				31
501	501.01	2		1				3
	Census Tract Total	2		1				3
502	502.03			4				4
	Census Tract Total			4				4
503	503.01			1				1
	503.03			19				19
	503.04			19				19
	Census Tract Total			39				39
504	504.01			4				4
	504.03	1		4				5
	Census Tract Total	1		8				9
505	505.03				6			6
	Census Tract Total				6			6
506	506.02				14			14

(CONTINUED)

Summary of Residential Development Activity  
Census and Subcensus Tract  
(January 1995)

Census Tract	Subcensus Tract	Under Construction	Bldg Permit Issued, No Construction	Site Plan and/or Subdivision Plat Apprvd	Site Plan and/or Subdivision Plat Submtd	Rezoning Granted	Rezoning Pending	Total Development Activity
506	506.05				10			10
	506.07	1						1
	<b>Census Tract Total</b>	1			24			25
507	507.01	1	3	6				10
	507.02	4	2	13				19
	<b>Census Tract Total</b>	5	5	19				29
508	508.02			2				2
	508.03			1				1
	<b>Census Tract Total</b>			3				3
510	510.01			1				1
	510.02			2				2
	<b>Census Tract Total</b>			3				3
511	511.01			5				5
	511.02			3				3
	<b>Census Tract Total</b>			8				8
512	512.02			1				1
	<b>Census Tract Total</b>			1				1
513	513.01			18	2			20
	513.02				4			4
	<b>Census Tract Total</b>			18	6			24
515	515.02	1		3	17			21
	515.03		2	3	3	6		14
	515.04			5				5
	<b>Census Tract Total</b>	1	2	11	20	6		40
516	516.01				43			43
	516.04			14				14
	516.05			2				2
	<b>Census Tract Total</b>			16	43			59
518	518.01	1		1				2

(CONTINUED)

Summary of Residential Development Activity  
Census and Subcensus Tract  
(January 1995)

Census Tract	Subcensus Tract	Under Construction	Bldg Permit Issued, No Construction	Site Plan and/or Subdivision Plat Apprvd	Site Plan and/or Subdivision Plat Submtd	Rezoning Granted	Rezoning Pending	Total Development Activity
518	518.02		2	6				8
	518.03	3		4				7
	Census Tract Total	4	2	11				17
519	519.01	2		9	9			20
	Census Tract Total	2		9	9			20
520	520.01			9		18		27
	Census Tract Total			9		18		27
521	521.01			1				1
	521.02			3				3
	521.03	1					7	8
	521.04	5	2	1	4			12
	521.05			3				3
	Census Tract Total	6	2	8	4		7	27
524	524.03				6			6
	524.05	2		13				15
	Census Tract Total	2		13	6			21
525	525.02		1	4				5
	525.03			4				4
	525.04			103				103
	Census Tract Total		1	111				112
526	526.01				19			19
	526.02			1			487	488
	526.03				144			144
	Census Tract Total			1	163		487	651
527	527.01			4	114			118
	Census Tract Total			4	114			118
528	528.01	1	66					67
	Census Tract Total	1	66					67
601	601.01			3				3

(CONTINUED)

Summary of Residential Development Activity  
Census and Subcensus Tract  
(January 1995)

Census Tract	Subcensus Tract	Under Construction	Bldg Permit Issued, No Construction	Site Plan and/or Subdivision Plat Apprvd	Site Plan and/or Subdivision Plat Submtd	Rezoning Granted	Rezoning Pending	Total Development Activity
601	601.02	3		4				7
	601.03				13			13
	Census Tract Total	3		7	13			23
602	602.01	8		33	18			59
	602.02	2		10				12
	Census Tract Total	10		43	18			71
603	603.01			15		119		134
	603.02			7				7
	Census Tract Total			22		119		141
604	604.01			13	14		57	84
	604.02	18	5	94	12	4		133
	604.03	1		6				7
	Census Tract Total	19	5	113	26	4	57	224
605	605.01	28	5	85	63	51	8	240
	605.02	5	4	13	21			43
	605.03	5	4	9		5	2	25
	605.04	1		2	5			8
	605.05	6	2		34		18	60
	Census Tract Total	45	15	109	123	56	28	376
606	606.01			2				2
	606.02	1	5		28		35	69
	Census Tract Total	1	5	2	28		35	71
607 /1	607.01	5			7			12
	Census Tract Total	5			7			12
608 /1	608.01	2	1		25			28
	Census Tract Total	2	1		25			28
609 /1	609.01	7	4					11
	Census Tract Total	7	4					11
611	611.01	1		4				5

(CONTINUED)

Summary of Residential Development Activity  
Census and Subcensus Tract  
(January 1995)

Census Tract	Subcensus Tract	Under Construction	Bldg Permit Issued, No Construction	Site Plan and/or Subdivision Plat Apprvd	Site Plan and/or Subdivision Plat Submtd	Rezoning Granted	Rezoning Pending	Total Development Activity
611	611.02	17	6	41	103	19		186
	Census Tract Total	18	6	45	103	19		191
612	612.01	3	5	24				32
	612.02	15	10	55	109			189
	612.03		1					1
	612.04	12	6	260	9			287
	Census Tract Total	30	22	339	118			509
615	615.01	22	5	23	24			74
	615.03	2	1	28				31
	615.04	29	1	41	11			82
	Census Tract Total	53	7	92	35			187
616	616.02	1		8				9
	616.05			1				1
	Census Tract Total	1		9				10
617	617.01	27	13	127	84	2		253
	617.02	1		4	13			18
	Census Tract Total	28	13	131	97	2		271
618	618.02			6				6
	Census Tract Total			6				6
701	701.01	1		1	14			16
	701.02	4		24				28
	701.03			5				5
	701.04			1	23			24
	Census Tract Total	5		31	37			73
703	703.01	1	5	10				16
	703.02	2	2	9				13
	703.03	4	1	26				31
	Census Tract Total	7	8	45				60
704	704.01		1	19			20	

(CONTINUED)

Summary of Residential Development Activity  
Census and Subcensus Tract  
(January 1995)

Census Tract	Subcensus Tract	Under Construction	Bldg Permit Issued, No Construction	Site Plan and/or Subdivision Plat Apprvd	Site Plan and/or Subdivision Plat Submtd	Rezoning Granted	Rezoning Pending	Total Development Activity
704	704.02			2				2
	704.03	2		3				5
	704.04	1		1		2		4
	<b>Census Tract Total</b>	<b>3</b>	<b>1</b>	<b>25</b>		<b>2</b>		<b>31</b>
705	705.03	1		51			4	56
	705.04				10			10
	705.05			29				29
	705.06						67	67
	<b>Census Tract Total</b>	<b>1</b>		<b>80</b>	<b>10</b>		<b>71</b>	<b>162</b>
706	706.01	1		5	38			44
	706.04			9				9
	<b>Census Tract Total</b>	<b>1</b>		<b>14</b>	<b>38</b>			<b>53</b>
707	707.01	1		9	4			14
	707.02	1		1	5			7
	707.03	3	2	6				11
	707.05				45			45
	707.06	1	1					2
	<b>Census Tract Total</b>	<b>6</b>	<b>3</b>	<b>16</b>	<b>54</b>			<b>79</b>
708	708.01			1				1
	708.02				2			2
	<b>Census Tract Total</b>			<b>1</b>	<b>2</b>			<b>3</b>
709	709.01	4	1	30	3			38
	709.02	1	1	10				12
	709.03	1		2				3
	709.05			2				2
	709.06			1				1
	<b>Census Tract Total</b>	<b>6</b>	<b>2</b>	<b>45</b>	<b>3</b>			<b>56</b>
710	710.02			1				1
	710.03	2	12	11	252			277

(CONTINUED)



Summary of Residential Development Activity  
Census and Subcensus Tract  
(January 1995)

Census Tract	Subcensus Tract	Under Construction	Bldg Permit Issued, No Construction	Site Plan and/or Subdivision Plat Apprvd	Site Plan and/or Subdivision Plat Submtd	Rezoning Granted	Rezoning Pending	Total Development Activity
710	Census Tract Total	2	12	12	252			278
711	711.03	1						1
	711.04			1				1
	711.08			1				1
	Census Tract Total	1		2				3
712	712.02						631	631
	712.03			14				14
	712.04			31				31
	Census Tract Total			45			631	676
713	713.01		1	6	6			13
	713.02			6				6
	Census Tract Total		1	12	6			19
714	714.01	12	1	10				23
	714.02			4				4
	Census Tract Total	12	1	14				27
801	801.01	16	3	80				99
	801.02	3		4				7
	801.03	4		25	29			58
	801.04	3	3	34		7		47
	801.05	3	1	11	2			17
	Census Tract Total	29	7	154	31	7		228
802	802.01	10	3	23				36
	802.02	5	2	10				17
	802.03			8				8
	802.04			1	572			573
	802.05			10				10
	Census Tract Total	15	5	52	572			644
803	803.01	5	2	31	45			83
	803.03	23	2	142				167

(CONTINUED)

Summary of Residential Development Activity  
Census and Subcensus Tract  
(January 1995)

Census Tract	Subcensus Tract	Under Construction	Bldg Permit Issued, No Construction	Site Plan and/or Subdivision Plat Apprvd	Site Plan and/or Subdivision Plat Submtd	Rezoning Granted	Rezoning Pending	Total Development Activity
803	Census Tract Total	28	4	173	45			250
804	804.01	18	3	46	3			70
	804.02	18	6	77	27			128
	804.03	7		6	6			19
	804.04	6	5	14	46			71
	804.05	10	6	25	3			44
	Census Tract Total	59	20	168	85			332
805	805.01	10	10	87	51			158
	805.02	16	9	60		217	63	365
	805.03	2		26	388			416
	Census Tract Total	28	19	173	439	217	63	939
808 /2	808.01	69	128	180	61	26	9	473
	Census Tract Total	69	128	180	61	26	9	473
809 /2	809.01	69	128	180	61	26	9	473
	Census Tract Total	69	128	180	61	26	9	473
810	810.01				108			108
	Census Tract Total				108			108
811	811.01				110		562	672
	811.02	65	29	202	1,213	178		1,687
	811.03	37	27	75	62	73	9	283
	811.04			31			130	161
	Census Tract Total	102	56	308	1,385	251	701	2,803
812	812.01	18	4	29		115		166
	Census Tract Total	18	4	29		115		166
814	814.01	1	1	1				3
	Census Tract Total	1	1	1				3
815	815.01	1		6	5			12
	Census Tract Total	1		6	5			12
816	816.01		1	15	5			21

(CONTINUED)

Summary of Residential Development Activity  
Census and Subcensus Tract  
(January 1995)

Census Tract	Subcensus Tract	Under Construction	Bldg Permit Issued, No Construction	Site Plan and/or Subdivision Plat Apprvd	Site Plan and/or Subdivision Plat Submtd	Rezoning Granted	Rezoning Pending	Total Development Activity
816	816.02	2	1	6				9
	Census Tract Total	2	2	21	5			30
817	817.01	3		5	5			13
	817.02	22	3	89	36			150
	817.03	2		2	4			8
	817.04	39	1	57	5			102
	Census Tract Total	66	4	153	50			273
819	819.01	4	15	50	18	20		107
	819.02	3		22	124			149
	Census Tract Total	7	15	72	142	20		256
820	820.01	68	52	24	748			892
	Census Tract Total	68	52	24	748			892
821	821.01	1						1
	Census Tract Total	1						1
822	822.01	9	64		180			253
	Census Tract Total	9	64		180			253
823	823.01	2						2
	Census Tract Total	2						2
824	824.01	17	6	9	317			349
	Census Tract Total	17	6	9	317			349
825	825.01	4	1	9	145	521		680
	825.02	7	3	29	49			88
	Census Tract Total	11	4	38	194	521		768
826	826.01	1	1	14				16
	826.02	18	11	88	74	13		204
	Census Tract Total	19	12	102	74	13		220
901	901.05		5	1				6
	Census Tract Total		5	1				6
905	905.01			6	10	6	38	60

(CONTINUED)

Summary of Residential Development Activity  
Census and Subcensus Tract  
(January 1995)

Census Tract	Subcensus Tract	Under Construction	Bldg Permit Issued, No Construction	Site Plan and/or Subdivision Plat Apprvd	Site Plan and/or Subdivision Plat Submt'd	Rezoning Granted	Rezoning Pending	Total Development Activity
905	905.02	7	4	109	2		16	138
	Census Tract Total	7	4	115	12	6	54	198
909 /3	909.01		1					1
	Census Tract Total		1					1
910	910.02			2				2
	Census Tract Total			2				2
911	911.01	17	10	56	18			101
	Census Tract Total	17	10	56	18			101
912	912.01	39	12	177	42	3		273
	912.02	2	359		504			865
	Census Tract Total	41	371	177	546	3		1,138
913	913.02			1				1
	913.03	13	148	29	151			341
	913.04	101	14	250	471	26		862
	Census Tract Total	114	162	280	622	26		1,204
914	914.01	44	17	200		86	31	378
	Census Tract Total	44	17	200		86	31	378
915	915.01	22	14	68	203			307
	915.02	13		167	43	2		225
	Census Tract Total	35	14	235	246	2		532
916	916.01	3	4	18			160	185
	Census Tract Total	3	4	18			160	185
917	917.01			1	108	211		320
	917.02		301		82			383
	917.03	39	11	86	31		199	366
	917.04	24	1	2	199			226
	Census Tract Total	63	313	89	420	211	199	1,295
918	918.01	45			618		30	693
	Census Tract Total	45			618		30	693

(CONTINUED)

Summary of Residential Development Activity  
Census and Subcensus Tract  
(January 1995)

Census Tract	Subcensus Tract	Under Construction	Bldg Permit Issued, No Construction	Site Plan and/or Subdivision Plat Apprvd	Site Plan and/or Subdivision Plat Submtd	Rezoning Granted	Rezoning Pending	Total Development Activity
919	919.01	1	1	8				10
	919.02	3	1	3	119			126
	919.03	3		5				8
	919.04	1	8					9
	919.05	1		9	245			255
	919.06	2	1	7				10
	919.07	3		32				35
	919.08			4				4
	919.09	1		4				5
	919.10			1				1
	919.11			2				2
	919.12			2				2
		<b>Census Tract Total</b>	<b>15</b>	<b>11</b>	<b>77</b>	<b>364</b>		
920	920.01	6		69	11			86
	920.02	3		8				11
	920.03	3		28	20			51
		<b>Census Tract Total</b>	<b>12</b>		<b>105</b>	<b>31</b>		
921	921.01	1		4				5
	921.02	3	2	22				27
	921.03	7	1	31				39
	921.04	2		4				6
	921.05	12	11	27				50
	921.06		1	15				16
	921.07			4				4
		<b>Census Tract Total</b>	<b>25</b>	<b>15</b>	<b>107</b>			
922	922.01			9				9
	922.02	2	2	19				23
	922.03	40	20	168				228
	922.04			46	33	87		166

(CONTINUED)

Summary of Residential Development Activity  
Census and Subcensus Tract  
(January 1995)

Census Tract	Subcensus Tract	Under Construction	Bldg Permit Issued, No Construction	Site Plan and/or Subdivision Plat Apprvd	Site Plan and/or Subdivision Plat Submtd	Rezoning Granted	Rezoning Pending	Total Development Activity
922	922.05	31	13	133	26	37		240
	Census Tract Total	73	35	375	59	124		666
923	923.01			9	5			14
	Census Tract Total			9	5			14
924	924.01			10			6	16
	Census Tract Total			10			6	16
<b>Total</b>		<b>1,736</b>	<b>1,964</b>	<b>7,270</b>	<b>12,495</b>	<b>2,772</b>	<b>2,930</b>	<b>29,167</b>

Notes: All numbers shown in the table refer to housing units.

Single Family category includes only single family detached units. Townhouse includes townhouses, duplexes, and multiplex units. Multifamily includes condominium and rental garden, medium-rise and high-rise apartment units.

- 1/ Comprises part of the Town of Vienna.
- 2/ Comprises part of the Town of Herndon.
- 3/ Town of Clifton.

# VIII. NONRESIDENTIAL GROSS FLOOR AREA

## NONRESIDENTIAL GROSS FLOOR AREA

As of January 1995, there was a total of 183,196,017 square feet of nonresidential structure gross floor area in Fairfax County. This figure represents an increase of 1,703,585 square feet, or 0.9 percent over the January 1994 total gross floor area of 181,492,432 square feet.

As shown in Table 8.1, of the 183,196,017 square feet of nonresidential gross floor area in the County, Office use accounts for 74,684,888 square feet, or 40.8 percent of the total. Retail structures comprise 40,337,190 square feet, or 22.0 percent of the gross floor area in the County. Industrial structures account for 36,162,495 square feet, or 19.7 percent of the County total. With a total of 32,011,444 square feet, Institutional structures make up 17.5 percent of the total square footage in the County.

TABLE 8.1

Nonresidential Structure Gross Floor Area  
by General Activity Type  
January 1995

General Activity Type	Gross Floor Area	Percent of Total
Retail	40,337,190	22.0%
Office	74,684,888	40.8
Industrial	36,162,495	19.7
Institutional	32,011,444	17.5
<b>Fairfax County</b>	<b>183,196,017</b>	<b>100.0%</b>

### Nonresidential Gross Floor Area by Year Built

Year built totals of nonresidential gross floor area by structure type are presented in Figure 8.1 and the table entitled: "Nonresidential Structure Gross Floor Area by General Activity, Inventory of Existing Structures by Year Built." As is shown, for structures built prior to 1982, Institutional structures represent the largest share of gross floor area in the County. This structure type includes government buildings, as well as houses of worship. Since 1982, the County has added almost 48.0 million square feet of office space, more than 16.4 million square feet of industrial space, more than 15.0 million square feet of retail space, while adding only slightly more than 5.2 million square feet of institutional space.

It should be noted that these data are continuously updated and represent the latest information available on the gross floor area of nonresidential structures by year built. Yearly totals may change due to newly available information, structure demolitions or use modifications. The yearly figures presented are totals of gross floor area for structures currently existing that were built during that particular year.

### Nonresidential Gross Floor Area, Supervisor District and Planning District

Among the County's supervisor districts, Providence District has the largest gross floor area total with 44,654,062 square feet, nearly one-fourth of the entire Fairfax County inventory. This district includes much of the Tysons Corner, Merrifield and Fairfax Center areas. The Sully District has the second largest gross floor area total, 28,166,243 square feet, which includes Fair Oaks, Chantilly and Centreville. The Springfield Supervisor District has the smallest share of the County's gross floor area with 4,823,878 square feet.



The greatest concentration of Office square footage exists in the Providence District, with a total of 27,056,499 square feet of gross floor area in office use. Providence District also has the largest accumulation of Retail square footage, at 8,230,032 square feet, and Institutional floor area at 4,747,677 square feet. The Lee District has the largest amount of Industrial space, 8,348,313 square feet, followed by the Sully District with 8,114,856 square feet.

Among the County's planning districts, the Upper Potomac Planning District accounts for the largest portion of the nonresidential gross floor area with 32,067,858 square feet, or 17.5 percent of the total. This district includes the town of Herndon, the Reston area, and much of the Route 28 Corridor. Other planning districts having significant totals include McLean with 25,848,063 square feet, Springfield with a gross floor area total of 18,186,058 square feet, and Bull Run with a total gross floor area of 17,595,800 square feet. Westgate and Tysons Corner are two areas within the McLean Planning District with high concentrations of nonresidential structures. Newington is one of the major nonresidential developments within the Springfield Planning District. The planning districts with the smallest gross floor area totals in the County include Lower Potomac with 2,210,001 square feet and Rose Hill with 2,863,331 square feet.

Table 8.2 shows the individual land use categories included in each of the General Activity Types that are presented in the data tables in the section.

# Existing Nonresidential Structure Gross Floor Area By Year Built and Structure Type, 1965 to 1995

Figure 8.1

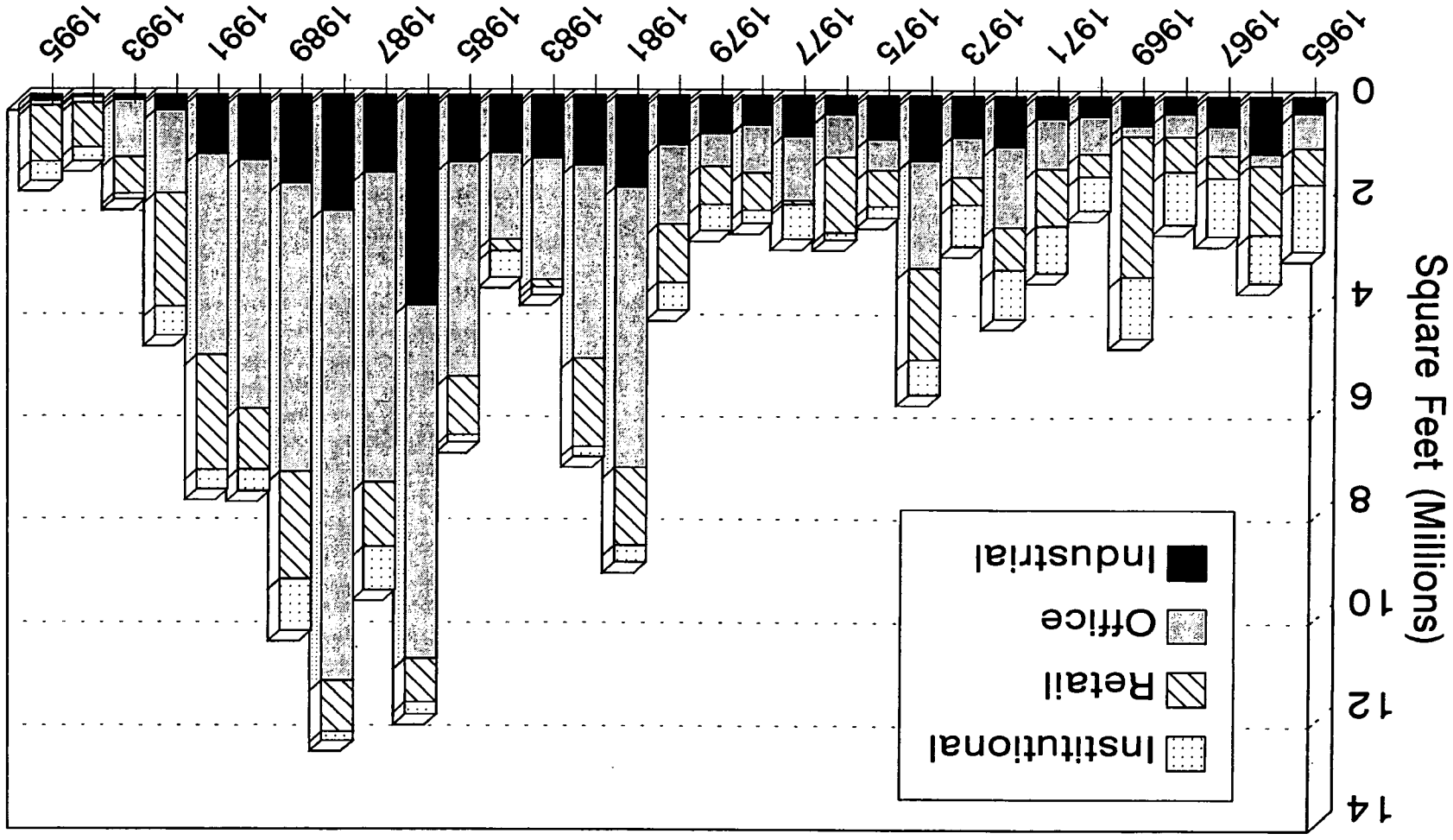

Source: Fairfax County Office of Management and Budget.

TABLE 8.2

**Nonresidential Land Use Categories by General Activity Type**

**Retail**

Community Shopping Center  
 Condominium Center  
 Neighborhood Shopping Center  
 Promotional Center  
 Regional Shopping Center  
 Specialty Shopping Center  
 Super Regional Center  
 Town Center  
 Other Retail  
 Apparel & Accessories  
 Building Material-Hardware  
 Condominium Retail  
 Department and Variety Stores  
 Drug Stores  
 Food Store  
 Furniture  
 Gas Station  
 Motels, Hotels, Tourist Homes  
 Motor Vehicle Sales  
 Other Auto Retail and Repair  
 Other Retail  
 Personal and Repair Service  
 Restaurants  
 Veterinary Hospitals

**Office**

Cluster Office  
 Condominium Office  
 Finance, Insurance, Real Estate  
 General Low Rise Office  
 General Medium/High Rise Office  
 Other Office

**Industrial**

Communication Related  
 Contract Construction  
 Manufacturing  
 Other Industrial  
 Printing and Publishing  
 Quarries  
 Research and Testing  
 Transportation Related  
 Utility Related  
 Wholesale-Warehouse & Storage

**Institutional**

Cemeteries  
 Civic, Social, and Fraternal Uses  
 Colleges & Universities  
 Correctional Institutions  
 Fire Stations  
 Golf Courses  
 Horticultural Activities  
 Hospital & Health Facilities  
 House of Worship  
 Indoor Recreation Facility  
 Libraries  
 Military Institutions  
 Nursery Schools  
 Nursing Homes  
 Other Institutional Use  
 Other Public Land Uses  
 Parks  
 Permanent Exhibitions  
 Places of Public Assembly  
 Police Stations  
 Post Office  
 Private Schools  
 Public Schools  
 Special Training Schools

Nonresidential Structure Gross Floor Area by General Activity  
Inventory of Existing Structures by Year  
(January 1995)

Year	Industrial	Office	Retail	Institutional	Total
1959 and Earlier	147,455	75,944	20,367	1,920,602	2,164,368
1965	5,614,034	3,873,003	7,126,318	15,535,780	32,149,135
1970	8,648,567	6,082,375	12,841,590	20,562,780	48,135,312
1975	13,032,235	12,199,285	17,863,248	24,171,921	67,266,689
1980	16,511,873	17,492,629	22,083,224	26,288,590	82,376,316
1981	18,333,146	22,983,233	23,587,112	26,610,659	91,514,150
1982	19,717,037	26,778,404	25,312,340	26,805,913	98,613,694
1983	20,957,979	29,171,168	25,462,323	26,956,883	102,548,353
1984	22,087,128	30,893,011	25,684,734	27,476,293	106,141,166
1985	23,403,330	35,111,664	26,827,015	27,623,317	112,965,326
1986	27,539,363	41,999,660	27,667,695	27,860,508	125,067,226
1987	29,074,457	48,065,909	28,913,904	28,697,210	134,751,480
1988	31,370,439	57,220,534	29,909,248	28,866,059	147,366,280
1989	33,115,881	62,874,581	31,980,744	29,875,901	157,847,107
1990	34,402,551	67,757,226	33,170,081	30,292,302	165,622,160
1991	35,567,423	71,712,520	35,411,161	30,676,813	173,367,917
1992	35,878,643	73,352,921	37,630,444	31,240,688	178,102,696
1993	35,981,154	74,479,268	38,364,970	31,355,074	180,180,466
1994	36,037,097	74,589,831	39,237,218	31,628,286	181,492,432
1995	36,162,495	74,684,888	40,337,190	32,011,444	183,196,017

Notes: Totals based on year built of each nonresidential structure in current County inventory.  
All data in square feet.

Nonresidential Structure Gross Floor Area by General Activity  
Supervisor District  
(January 1995)

Supervisor District	Structure Type				Total Gross Floor Area
	Industrial	Office	Retail	Institutional	
Braddock	2,249,124	1,200,916	959,339	4,678,460	9,087,839
Dranesville 1/	1,618,407	9,071,392	2,714,642	3,764,383	17,168,824
Hunter Mill 2/	1,388,182	17,423,141	4,716,956	2,875,635	26,403,914
Lee	8,348,313	2,044,557	6,676,207	3,322,512	20,391,589
Mason	4,969,100	7,063,371	6,616,248	3,485,253	22,133,972
Mount Vernon	4,440,968	873,365	1,662,351	3,389,012	10,365,696
Providence	4,619,854	27,056,499	8,230,032	4,747,677	44,654,062
Springfield 3/	413,691	439,378	1,489,808	2,481,001	4,823,878
Sully	8,114,856	9,512,269	7,271,607	3,267,511	28,166,243
Fairfax County Total	36,162,495	74,684,888	40,337,190	32,011,444	183,196,017

Nonresidential Structure Gross Floor Area by General Activity  
Towns  
(January 1995)

Town	Structure Type				Total Gross Floor Area
	Industrial	Office	Retail	Institutional	
Town of Clifton		19,927	18,966	24,699	63,592
Town of Herndon	661,234	4,367,360	1,519,231	443,712	6,991,537
Town of Vienna	310,787	1,910,489	934,338	549,263	3,704,877
Towns Total	972,021	6,297,776	2,472,535	1,017,674	10,760,006

Note: All data in square feet.

- 1/ Includes the Town of Herndon.
- 2/ Includes the Town of Vienna.
- 3/ Includes the Town of Clifton.

Nonresidential Structure Gross Floor Area by General Activity  
 Planning District.  
 (January 1995)

Planning District	Structure Type				Total Gross Floor Area
	Industrial	Office	Retail	Institutional	
Annandale	4,219,948	3,320,908	1,600,238	3,077,200	12,218,294
Baileys	441,183	3,855,372	3,557,407	1,134,320	8,988,282
Bull Run	6,342,945	5,013,767	3,733,969	2,505,119	17,595,800
Fairfax	319,612	7,070,022	2,722,601	2,766,910	12,879,145
Jefferson	3,251,310	6,843,079	2,486,699	2,476,894	15,057,982
Lincolnia	2,076,712	485,863	1,268,446	443,089	4,274,110
Lower Potomac	1,926,641	18,814	74,944	189,602	2,210,001
McLean	1,647,798	15,758,345	5,721,373	2,720,547	25,848,063
Mount Vernon	135,818	1,127,758	3,636,953	3,660,658	8,561,187
Pohick 1/	450,582	547,368	1,816,899	3,872,616	6,687,465
Rose Hill	260,445	246,757	614,187	1,741,942	2,863,331
Springfield	10,848,594	1,692,801	4,140,590	1,504,073	18,186,058
Upper Potomac 2/	3,668,475	19,305,799	5,302,440	3,791,144	32,067,858
Vienna 3/	572,432	9,398,235	3,660,444	2,127,330	15,758,441
Fairfax County Total	36,162,495	74,684,888	40,337,190	32,011,444	183,196,017

Note: All data in square feet.

- 1/ Includes the Town of Clifton.
- 2/ Includes the Town of Vienna.
- 3/ Includes the Town of Herndon.

Nonresidential Structure Gross Floor Area by General Activity  
Sewershed  
(January 1995)

Sewershed Code	Activity Type				Total Gross Floor Area
	Institutional	Commercial Retail	Industrial	Commercial Office	
A1	240,222	465,168	1,356,510	787,182	2,849,082
A2	3,187	643,064		1,356,776	2,003,027
A3	105,210			173,160	278,370
B1	85,064		380,201	3,681,248	4,146,513
B2	849,654	893,448	105,150	1,770,541	3,618,793
B3	4,810	3,470		1,817	10,097
B5 1/	443,712	1,519,231	661,234	4,367,360	6,991,537
C1	5,924	11,596		396	17,916
C2	143,599	9,212	10,366	40,826	204,003
D1	137,487	195,514	381,172	37,072	751,245
D2	604,559	195,538	521,916	3,858,236	5,180,249
D3	1,958,356	4,379,680	1,512,221	13,068,544	20,918,801
E1	280,463	4,251,710	230,027	9,235,035	13,997,235
E2	11,835	9,422		6,151	27,408
F	439,974	241,334	891	987,185	1,669,384
G1	1,360,065	780,078	158,389	1,948,958	4,247,490
G2	48,268	88,021		11,825	148,114
G3	225,288			1,472,000	1,697,288
H1	308,707	2,907,123	389,887	933,243	4,538,960
H2		324,940		2,523,049	2,847,989
H3	3,336				3,336
I1	3,205,013	2,405,408	1,343,870	5,249,797	12,204,088
I2	457,079	16,783	23,623	73,611	571,096
I3	3,326,958	3,099,866	5,651,032	3,036,238	15,114,094
I4	1,676	460,687			462,363
J1	253,712	479,086	43,621	381,331	1,157,750

(CONTINUED)

Note: All data in square feet.

- 1/ Town of Herndon.
- 2/ Comprises part of the Town of Vienna.
- 3/ Includes the Town of Clifton.

Nonresidential Structure Gross Floor Area by General Activity  
Sewershed  
(January 1995)

Sewershed Code	Activity Type				Total Gross Floor Area
	Institutional	Commercial Retail	Industrial	Commercial Office	
J2	136,096	717,435	11,713	82,208	947,452
J3	217,358	373,738		183,915	775,011
J4	544,606	238,062	1,044	31,459	815,171
K	1,799,511	1,249,292	69,648	190,573	3,309,024
L	1,739,523	881,890	111,192	346,945	3,079,550
M0	133,573	89,544	258,067	120,098	601,282
M1	97,811	60,907		1,529,295	1,688,013
M2 2/	3,050,132	1,089,547	2,226,870	4,849,814	11,216,363
M3	806,814	221,840	556,300	401,147	1,986,101
M4	1,091,781	716,067	1,661,414	581,471	4,050,733
M5	11,984	355,588	3,615,612	125,778	4,108,962
M6	146,643	2,196,229	7,158,235	698,009	10,199,116
M7	3,250	16,706		1,380	21,336
M8	20,757			8,090	28,847
M9	46,266	2,197,611		3,864,528	6,108,405
N1	3,587,751	1,597,976	774,134	338,803	6,298,664
N2	180,929	19,592	2,376		202,897
O1	17,429				17,429
P	79,125		4,000		83,125
P1	4,800	25,456	206,749	4,760	241,765
P3	82,595		2,952		85,547
Q1	43,323	7,000	22,572	2,608	75,503
R1	215,201	45,692	26,146		287,039
R2	12,970				12,970
R3 3/	24,699	18,966		19,927	63,592
R4	13,605			3,360	16,965

(CONTINUED)

Note: All data in square feet.

- 1/ Town of Herndon.
- 2/ Comprises part of the Town of Vienna.
- 3/ Includes the Town of Clifton.



Nonresidential Structure Gross Floor Area by General Activity  
Sewershed  
(January 1995)

Sewershed Code	Activity Type				Total Gross Floor Area
	Institutional	Commercial Retail	Industrial	Commercial Office	
S1	743,071	181,503		3,102	927,676
S2	3,377				3,377
T1	196,844	766,114	4,901,267	1,387,675	7,251,900
T2	421,443	1,192,837	1,520,288	1,508,830	4,643,398
T3	589,674			9,484	599,158
T4	973,136	926,391	42,160	3,195,227	5,136,914
T5	441,821	1,770,828	69,234	194,821	2,476,704
T6	1,560		14,835		16,395
T7	27,828		135,577		163,405
FAIRFAX COUNTY TOTAL	32,011,444	40,337,190	36,162,495	74,684,888	183,196,017

Note: All data in square feet.

- 1/ Town of Herndon.
- 2/ Comprises part of the Town of Vienna.
- 3/ Includes the Town of Clifton.

Nonresidential Structure Gross Floor Area by General Activity  
Census and Subcensus Tract  
(January 1995)

Census Tract	Subcensus Tract	Activity Type				Total Gross Floor Area
		Institutional	Commercial Retail	Industrial	Commercial Office	
151	151.01		116,145			116,145
	151.02	432,960	237,613		34,412	704,985
	151.03	19,213				19,213
	Census Tract Total	452,173	353,758		34,412	840,343
152	152.01	16,064	101,916		148,623	266,603
	152.02	150,000	233,091	1,044	22,030	406,165
	Census Tract Total	166,064	335,007	1,044	170,653	672,768
153	153.01	9,840	25,811		44,669	80,320
	153.02	52,152				52,152
	153.04	50,564				50,564
	Census Tract Total	112,556	25,811		44,669	183,036
154	154.01	225,339	105,688			331,027
	154.02	7,444				7,444
	154.03	6,531	13,020	1,680	40,599	61,830
	Census Tract Total	239,314	118,708	1,680	40,599	400,301
155	155.01	572,066	19,357		113,132	704,555
	155.02	103,858	46,464			150,322
	155.03	36,324	71,299		5,382	113,005
	Census Tract Total	712,248	137,120		118,514	967,882
156	156.01	7,000				7,000
	156.03	17,689				17,689
	156.04	3,638				3,638
	Census Tract Total	28,327				28,327
157	157.01	8,175				8,175
	157.02	88,760				88,760
	157.03	3,825				3,825
	Census Tract Total	100,760				100,760
158	158.01	56,761				56,761
	158.02	300,391	4,234		16,960	321,585
	158.03	91,060	4,656			95,716

(CONTINUED)

Nonresidential Structure Gross Floor Area by General Activity  
Census and Subcensus Tract  
(January 1995)

Census Tract	Subcensus Tract	Activity Type				Total Gross Floor Area
		Institutional	Commercial Retail	Industrial	Commercial Office	
158	Census Tract Total	448,212	8,890		16,960	474,062
159	159.01	31,857				31,857
	159.02	538,206				538,206
	Census Tract Total	570,063				570,063
160	160.01	72,503	79,215	8,584	36,477	196,779
	160.02	23,500	55,297		57,170	135,967
	160.03	69,784				69,784
	Census Tract Total	165,787	134,512	8,584	93,647	402,530
161	161.01	40,967	155,369		83,276	279,612
	161.02	13,870				13,870
	161.03	54,787				54,787
	Census Tract Total	109,624	155,369		83,276	348,269
162	162.01	0			8,090	8,090
	Census Tract Total	0			8,090	8,090
163	163.01	18,873				18,873
	163.02	90,290				90,290
	Census Tract Total	109,163				109,163
201	201.01		184,228		44,222	228,450
	201.02	534,202		345,661		879,863
	Census Tract Total	534,202	184,228	345,661	44,222	1,108,313
202	202.01	28,108	164,954		135,485	328,547
	202.02	63,192	15,422	90,095	18,699	187,408
	Census Tract Total	91,300	180,376	90,095	154,184	515,955
203	203.01	156,909		12,000		168,909
	203.02	5,720				5,720
	203.03	38,822				38,822
	203.04	20,672	11,485		8,608	40,765
	Census Tract Total	222,123	11,485	12,000	8,608	254,216
204	204.01	1,560	108,821	40,285	137,479	288,145
	Census Tract Total	1,560	108,821	40,285	137,479	288,145

(CONTINUED)

Nonresidential Structure Gross Floor Area by General Activity  
Census and Subcensus Tract  
(January 1995)

Census Tract	Subcensus Tract	Activity Type				Total Gross Floor Area
		Institutional	Commercial Retail	Industrial	Commercial Office	
205	205.01		73,771	3,206	15,264	92,241
	205.02		53,243		2,368	55,611
	Census Tract Total		127,014	3,206	17,632	147,852
206	206.01	1,640	31,178		131,957	164,775
	206.02		66,212			66,212
	206.03	78,821	117,255			196,076
	Census Tract Total	80,461	214,645		131,957	427,063
207	207.01	55,668				55,668
	207.02	16,004				16,004
	207.03	38,966	10,372			49,338
	Census Tract Total	110,638	10,372			121,010
208	208.01	133,291				133,291
	208.03	3,872				3,872
	Census Tract Total	137,163				137,163
210	210.01	104,071	1,951,862		472,527	2,528,460
	210.02	28,125	18,947		118,128	165,200
	210.03	3,116		883,612		886,728
	210.04		21,208	1,782,444		1,803,652
	Census Tract Total	135,312	1,992,017	2,666,056	590,655	5,384,040
211	211.01		73,128	852,215	47,597	972,940
	211.02	490,233	5,397	65,904	2,151	563,685
	Census Tract Total	490,233	78,525	918,119	49,748	1,536,625
212	212.01	41,993				41,993
	Census Tract Total	41,993				41,993
213	213.01	90,273				90,273
	213.02	27,120	40,703		74,000	141,823
	Census Tract Total	117,393	40,703		74,000	232,096
214	214.01		483,607	11,843	37,492	532,942
	214.02	12,365	75,799	918	99,601	188,683
	Census Tract Total	12,365	559,406	12,761	137,093	721,625

(CONTINUED)

Nonresidential Structure Gross Floor Area by General Activity  
Census and Subcensus Tract  
(January 1995)

Census Tract	Subcensus Tract	Activity Type				Total Gross Floor Area
		Institutional	Commercial Retail	Industrial	Commercial Office	
215	215.01	162,652	849,362	67,050		1,079,064
	Census Tract Total	162,652	849,362	67,050		1,079,064
216	216.02	215,804	153,123	1,208	23,499	393,634
	Census Tract Total	215,804	153,123	1,208	23,499	393,634
217	217.01		10,031			10,031
	Census Tract Total		10,031			10,031
218	218.01	82,688	345,376		77,368	505,432
	Census Tract Total	82,688	345,376		77,368	505,432
219	219.01	2,075				2,075
	Census Tract Total	2,075				2,075
220	220.01		10,658	1,570,305	36,000	1,616,963
	220.02		1,568	674,415	59,510	735,493
	220.03		6,544	824,565		831,109
	220.04			513,729	2,784	516,513
	220.05	3,250	16,706		1,380	21,336
	Census Tract Total	3,250	35,476	3,583,014	99,674	3,721,414
221	221.01	3,802		5,496		9,298
	221.02			22,572		22,572
	221.03	32,732				32,732
	221.04	30,460	23,454	408,782		462,696
	221.05	8,120		31,200		39,320
	221.06		28,240	120,297	6,560	155,097
	Census Tract Total	75,114	51,694	588,347	6,560	721,715
223	223.01	471,264	269,062		7,814	748,140
	Census Tract Total	471,264	269,062		7,814	748,140
224	224.01	59,835	96,792	92,446		249,073
	Census Tract Total	59,835	96,792	92,446		249,073
301	301.01	147,451	125,242		16,000	288,693
	301.02	88,778	113,586		2,640	205,004
	301.03	12,003				12,003

(CONTINUED)

Nonresidential Structure Gross Floor Area by General Activity  
Census and Subcensus Tract  
(January 1995)

Census Tract	Subcensus Tract	Activity Type				Total Gross Floor Area
		Institutional	Commercial Retail	Industrial	Commercial Office	
301	Census Tract Total	248,232	238,828		18,640	505,700
302	302.01	816,412	110,850			927,262
	Census Tract Total	816,412	110,850			927,262
304	304.01	123,168	90,037	922	37,563	251,690
	304.02	64,029	131,803	1,092,899	239,145	1,527,876
	Census Tract Total	187,197	221,840	1,093,821	276,708	1,779,566
305	305.01	450				450
	Census Tract Total	450				450
306	306.01	17,688		42,663		60,351
	306.03	9,375	525,519		20,426	555,320
	306.04	65,576	369,636	437	224,243	659,892
	Census Tract Total	92,639	895,155	43,100	244,669	1,275,563
307	307.01	946		598,111		599,057
	307.02	60,219		96,543	10,842	167,604
	307.03	46,175		912		47,087
	Census Tract Total	107,340		695,566	10,842	813,748
308	308.01	413,998	93,212	382,217	168,208	1,057,635
	Census Tract Total	413,998	93,212	382,217	168,208	1,057,635
309	309.01	324,510	223,483		115,031	663,024
	Census Tract Total	324,510	223,483		115,031	663,024
310	310.01	117,200	361,867		35,346	514,413
	Census Tract Total	117,200	361,867		35,346	514,413
313	313.01	53,642			56,152	109,794
	Census Tract Total	53,642			56,152	109,794
314	314.01	51,170	1,920		4,850	57,940
	Census Tract Total	51,170	1,920		4,850	57,940
315	315.01	63,475	52,656			116,131
	Census Tract Total	63,475	52,656			116,131
316	316.01	63,234	3,084		7,504	73,822
	316.02	84,023	479,296	3,447	357,816	924,582

(CONTINUED)

Nonresidential Structure Gross Floor Area by General Activity  
Census and Subcensus Tract  
(January 1995)

Census Tract	Subcensus Tract	Activity Type				Total Gross Floor Area
		Institutional	Commercial Retail	Industrial	Commercial Office	
316	316.03			47,250		47,250
	Census Tract Total	147,257	482,380	50,697	365,320	1,045,654
318	318.01	598,535		162,851	190,263	951,649
	Census Tract Total	598,535		162,851	190,263	951,649
320	320.01	113,187		83,424	43,123	239,734
	Census Tract Total	113,187		83,424	43,123	239,734
321	321.01		105,529	172,833	24,172	302,534
	Census Tract Total		105,529	172,833	24,172	302,534
322	322.01	95,914	423,014		33,896	552,824
	Census Tract Total	95,914	423,014		33,896	552,824
323	323.01	104,292				104,292
	323.02	54,024				54,024
	Census Tract Total	158,316				158,316
324	324.01	255,454				255,454
	Census Tract Total	255,454				255,454
325	325.01	36,096	102,030			138,126
	Census Tract Total	36,096	102,030			138,126
326	326.01	11,024	2,976			14,000
	Census Tract Total	11,024	2,976			14,000
327	327.01	98,046	104,792			202,838
	Census Tract Total	98,046	104,792			202,838
328	328.01	9,850	355,588	3,568,362	125,778	4,059,578
	Census Tract Total	9,850	355,588	3,568,362	125,778	4,059,578
401	401.01	49,619				49,619
	401.02	69,334				69,334
	401.03	83,315	56,167	20,900	26,940	187,322
	Census Tract Total	202,268	56,167	20,900	26,940	306,275
402	402.01	948,313	502,382	626,688	1,596,139	3,673,522
	402.02	720,132			719,052	1,439,184
	402.03				1,431,248	1,431,248

(CONTINUED)

Nonresidential Structure Gross Floor Area by General Activity  
Census and Subcensus Tract  
(January 1995)

Census Tract	Subcensus Tract	Activity Type				Total Gross Floor Area
		Institutional	Commercial Retail	Industrial	Commercial Office	
402	402.04		12,347		28,950	41,297
	Census Tract Total	1,668,445	514,729	626,688	3,775,389	6,585,251
403	403.01	76,853	4,430		230,067	311,350
	403.02	104,071				104,071
	Census Tract Total	180,924	4,430		230,067	415,421
405	405.01	837,511			47,961	885,472
	405.02	9,890				9,890
	405.03	506,298			550	506,848
	405.04				99,176	99,176
	Census Tract Total	1,353,699			147,687	1,501,386
406	406.01	63,942	75,510	61,273		200,725
	Census Tract Total	63,942	75,510	61,273		200,725
407	407.01	62,670				62,670
	407.02	22,040				22,040
	Census Tract Total	84,710				84,710
408	408.01	64,133				64,133
	408.03	72,778				72,778
	408.04	378,328				378,328
	408.05	71,624				71,624
	Census Tract Total	586,863				586,863
501	501.01	67,365	245,124	437,740	626,694	1,376,923
	501.02	29,896	5,846			35,742
	501.03		163,349	2,700		166,049
	Census Tract Total	97,261	414,319	440,440	626,694	1,578,714
502	502.01	89,317	40,270			129,587
	502.02	5,355				5,355
	502.03	58,552	3,900		23,025	85,477
	502.04	57,497	10,794		32,224	100,515
	Census Tract Total	210,721	54,964		55,249	320,934
503	503.01		57,425	5,920	14,806	78,151

(CONTINUED)



Nonresidential Structure Gross Floor Area by General Activity  
Census and Subcensus Tract  
(January 1995)

Census Tract	Subcensus Tract	Activity Type				Total Gross Floor Area
		Institutional	Commercial Retail	Industrial	Commercial Office	
503	503.03	40,760	201,393	27,422	13,908	283,483
	503.04		33,228		440,611	473,839
	Census Tract Total	40,760	292,046	33,342	469,325	835,473
504	504.01	71,089	164,064		246,805	481,958
	504.02	3,600	8,122			11,722
	Census Tract Total	74,689	172,186		246,805	493,680
505	505.01		137,349			137,349
	505.02	74,448				74,448
	Census Tract Total	74,448	137,349			211,797
506	506.01				1,001,793	1,001,793
	506.02	449,846	254,736			704,582
	506.03	12,640	35,839			48,479
	506.04	35,529				35,529
	506.05	5,897				5,897
	506.07	8,400				8,400
	Census Tract Total	512,312	290,575		1,001,793	1,804,680
507	507.01	11,484			83,196	94,680
	507.02	41,226	226,079		202,747	470,052
	Census Tract Total	52,710	226,079		285,943	564,732
508	508.01	2,700				2,700
	508.02	118,622			1,344	119,966
	508.03	100,984	147,072		161,902	409,958
	Census Tract Total	222,306	147,072		163,246	532,624
509	509.01	3,006				3,006
	509.02	63,671				63,671
	Census Tract Total	66,677				66,677
510	510.02	94,466				94,466
	Census Tract Total	94,466				94,466
511	511.01	79,670				79,670
	Census Tract Total	79,670				79,670

(CONTINUED)

Nonresidential Structure Gross Floor Area by General Activity  
Census and Subcensus Tract  
(January 1995)

Census Tract	Subcensus Tract	Activity Type				Total Gross Floor Area
		Institutional	Commercial Retail	Industrial	Commercial Office	
512	512.01	92,170				92,170
	512.03	9,132				9,132
	Census Tract Total	101,302				101,302
513	513.01	8,536	168,584		271,041	448,161
	513.02	15,258	6,020		52,957	74,235
	Census Tract Total	23,794	174,604		323,998	522,396
514	514.01		65,130		1,944	67,074
	514.02	37,558	122,956			160,514
	514.03		283,848		32,126	315,974
	Census Tract Total	37,558	471,934		34,070	543,562
515	515.01		676,113		41,617	717,730
	515.02		4,167		110,000	114,167
	515.03	176,247	549,030		213,244	938,521
	515.04	12,051	693,780	162,777	414,719	1,283,327
	Census Tract Total	188,298	1,923,090	162,777	779,580	3,053,745
516	516.01	280,441				280,441
	516.02	5,680				5,680
	516.03	111,881	119,548			231,429
	516.04	10,302	256,932		57,072	324,306
	516.05		10,014		980	10,994
	Census Tract Total	408,304	386,494		58,052	852,850
518	518.01	57,256	114,743			171,999
	518.02	124,711				124,711
	518.03	32,758				32,758
	Census Tract Total	214,725	114,743			329,468
519	519.01	184,177	636,408		91,992	912,577
	Census Tract Total	184,177	636,408		91,992	912,577
520	520.01	132,779	261,446	2,208	432,460	828,893
	Census Tract Total	132,779	261,446	2,208	432,460	828,893
521	521.01	3,960				3,960

(CONTINUED)

Nonresidential Structure Gross Floor Area by General Activity  
Census and Subcensus Tract  
(January 1995)

Census Tract	Subcensus Tract	Activity Type				Total Gross Floor Area
		Institutional	Commercial Retail	Industrial	Commercial Office	
521	521.02	205,162	19,996	62,710	16,252	304,120
	521.03	137,070	259,018	4,436	85,522	486,046
	521.04	23,676	131,200		182,403	337,279
	521.05	344,630	16,927		34,844	396,401
	Census Tract Total	714,498	427,141	67,146	319,021	1,527,806
522	522.01	103,024	120,815	36,970	376,711	637,520
	522.02	393,716				393,716
	522.03	17,133				17,133
	Census Tract Total	513,873	120,815	36,970	376,711	1,048,369
523	523.01	8,288	67,778		110,592	186,658
	Census Tract Total	8,288	67,778		110,592	186,658
524	524.01	83,256				83,256
	524.04			637,952	25,200	663,152
	524.05	19,816	18,189		86,996	125,001
	Census Tract Total	103,072	18,189	637,952	112,196	871,409
525	525.01	68,307	101,640	2,024,916	491,139	2,686,002
	525.02	126,757	3,808	356,935	522,825	1,010,325
	525.03	147,315	158,843		94,630	400,788
	525.04	10,716	72,946		113,328	196,990
	Census Tract Total	353,095	337,237	2,381,851	1,221,922	4,294,105
526	526.01	51,821	400,249	1,586,228	153,861	2,192,159
	526.02	49,060			32,052	81,112
	526.03			490,484		490,484
	Census Tract Total	100,881	400,249	2,076,712	185,913	2,763,755
527	527.01	79,853	157,760	278,406	133,653	649,672
	Census Tract Total	79,853	157,760	278,406	133,653	649,672
528	528.01	816	328,782		2,526,019	2,855,617
	Census Tract Total	816	328,782		2,526,019	2,855,617
601	601.01	5,928				5,928
	601.02	1,647		3,120		4,767

(CONTINUED)

Nonresidential Structure Gross Floor Area by General Activity  
Census and Subcensus Tract  
(January 1995)

Census Tract	Subcensus Tract	Activity Type				Total Gross Floor Area
		Institutional	Commercial Retail	Industrial	Commercial Office	
601	601.03	13,856		222,250		236,106
	Census Tract Total	21,431		225,370		246,801
602	602.01	500				500
	602.02				2,542	2,542
	Census Tract Total	500			2,542	3,042
603	603.01	56,189				56,189
	603.02	4,316				4,316
	Census Tract Total	60,505				60,505
604	604.01	10,509				10,509
	604.02	52,542	1,549,641		2,251,720	3,853,903
	Census Tract Total	63,051	1,549,641		2,251,720	3,864,412
605	605.01	76,349	708,037		3,534,010	4,318,396
	605.02	179,351	4,186		137,152	320,689
	605.03			792		792
	605.04	52,597	2,630		219,409	274,636
	605.05	16,168			475,141	491,309
	Census Tract Total	324,465	714,853	792	4,365,712	5,405,822
606	606.01		6,345			6,345
	606.02	285,472				285,472
	Census Tract Total	285,472	6,345			291,817
607 1/	607.01	334,427	323,258	6,520	162,656	826,861
	Census Tract Total	334,427	323,258	6,520	162,656	826,861
608 1/	608.01	17,147	279,394		1,243,656	1,540,197
	Census Tract Total	17,147	279,394		1,243,656	1,540,197
609 1/	609.01	98,476	116,157	237,748	199,772	652,153
	Census Tract Total	98,476	116,157	237,748	199,772	652,153
610 1/	610.01	99,213	215,529	66,519	304,405	685,666
	Census Tract Total	99,213	215,529	66,519	304,405	685,666
611	611.01	61,553				61,553
	611.02	366,610	134,917		74,965	576,492

(CONTINUED)

Nonresidential Structure Gross Floor Area by General Activity  
Census and Subcensus Tract  
(January 1995)

Census Tract	Subcensus Tract	Activity Type				Total Gross Floor Area
		Institutional	Commercial Retail	Industrial	Commercial Office	
611	Census Tract Total	428,163	134,917		74,965	638,045
612	612.01	1,674				1,674
	612.02	151,670	51,550		52,191	255,411
	612.03		1,780		20,232	22,012
	612.04		283,905	73,470	2,092,199	2,449,574
	Census Tract Total	153,344	337,235	73,470	2,164,622	2,728,671
615	615.01	80,636	9,357		10,910	100,903
	615.02	13,617	1,878		6,370	21,865
	615.03	318,919				318,919
	615.04	3,133				3,133
	Census Tract Total	416,305	11,235		17,280	444,820
616	616.01	1,890		2,885	498,594	503,369
	616.02		7,626	27,785		35,411
	616.04	3,400	31,470	37,800	335,441	408,111
	616.05		7,000		115,489	122,489
	616.06	7,539	145,565	1,927,122	443,425	2,523,651
	Census Tract Total	12,829	191,661	1,995,592	1,392,949	3,593,031
617	617.01	4,300	223,256		59,332	286,888
	617.02	74,052	80,590	230,183	113,022	497,847
	Census Tract Total	78,352	303,846	230,183	172,354	784,735
618	618.01	9,293			816,341	825,634
	618.02				649,853	649,853
	Census Tract Total	9,293			1,466,194	1,475,487
619	619.02	54,364	5,284	121,809		181,457
	Census Tract Total	54,364	5,284	121,809		181,457
701	701.02	223,432				223,432
	701.03	1,856				1,856
	701.04	3,330				3,330
	Census Tract Total	228,618				228,618
702	702.01				1,472,000	1,472,000

(CONTINUED)

Nonresidential Structure Gross Floor Area by General Activity  
Census and Subcensus Tract  
(January 1995)

Census Tract	Subcensus Tract	Activity Type				Total Gross Floor Area
		Institutional	Commercial Retail	Industrial	Commercial Office	
702	Census Tract Total				1,472,000	1,472,000
703	703.02	1,701				1,701
	703.03	1,500	82,631			84,131
	Census Tract Total	3,201	82,631			85,832
704	704.01	178,251	150,540		102,377	431,168
	704.02		1,916			1,916
	704.03	69,922	1,800	1,588		73,310
	704.04	8,100				8,100
	Census Tract Total	256,273	154,256	1,588	102,377	514,494
705	705.01	70,000				70,000
	705.02	171,464		576		172,040
	705.03	28,433			18,032	46,465
	705.04	7,047				7,047
	705.05	36,333	10,457			46,790
	705.06	9,758	95,583		1,085,907	1,191,248
	Census Tract Total	323,035	106,040	576	1,103,939	1,533,590
706	706.01	17,093				17,093
	706.02	1,709	25,507		21,300	48,516
	706.03	73,420		315		73,735
	706.04	51,055	147,923		148,711	347,689
	Census Tract Total	143,277	173,430	315	170,011	487,033
707	707.01	36,245	184,111		358,420	578,776
	707.03	56,988		300		57,288
	707.04	53,980				53,980
	Census Tract Total	147,213	184,111	300	358,420	690,044
708	708.01	47,913				47,913
	708.02	245,773				245,773
	Census Tract Total	293,686				293,686
709	709.01		5,390		11,825	17,215
	709.02	60,308		4,010		64,318

(CONTINUED)

Nonresidential Structure Gross Floor Area by General Activity  
Census and Subcensus Tract  
(January 1995)

Census Tract	Subcensus Tract	Activity Type				Total Gross Floor Area
		Institutional	Commercial Retail	Industrial	Commercial Office	
709	709.04	158,003		704		158,707
	709.06	3,336				3,336
	Census Tract Total	221,647	5,390	4,714	11,825	243,576
710	710.01			152,491		152,491
	710.02	28,338				28,338
	710.03	416,100				416,100
	Census Tract Total	444,438		152,491		596,929
711	711.02	39,196				39,196
	711.06	37,330	49,622		363,161	450,113
	711.08	35,325				35,325
	Census Tract Total	111,851	49,622		363,161	524,634
712	712.01				804,911	804,911
	712.02			13,100	764,359	777,459
	712.04	188,256	71,960	127,346	1,954,361	2,341,923
	Census Tract Total	188,256	71,960	140,446	3,523,631	3,924,293
713	713.01	305,368	353,953		555,479	1,214,800
	713.02	5,224	16,783	22,975	73,611	118,593
	Census Tract Total	310,592	370,736	22,975	629,090	1,333,393
714	714.01	66,461	75,107	162,943	7,870	312,381
	714.02	63,721				63,721
	Census Tract Total	130,182	75,107	162,943	7,870	376,102
801	801.01	4,788				4,788
	801.02	10,236				10,236
	801.03	85,183	2,598	10,366	23,892	122,039
	801.04	32,848				32,848
	801.05	101,870				101,870
	Census Tract Total	234,925	2,598	10,366	23,892	271,781
802	802.01		4,123			4,123
	802.02	41,766			6,151	47,917
	802.03	43,082				43,082

(CONTINUED)

Nonresidential Structure Gross Floor Area by General Activity  
Census and Subcensus Tract  
(January 1995)

Census Tract	Subcensus Tract	Activity Type				Total Gross Floor Area
		Institutional	Commercial Retail	Industrial	Commercial Office	
802	802.04	65,609	2,244,147	2,100	7,261,493	9,573,349
	802.05	25,750	2,395,135		830,761	3,251,646
	Census Tract Total	176,207	4,643,405	2,100	8,098,405	12,920,117
803	803.01	2,088	130,958	83,769		216,815
	803.02		3,379			3,379
	803.03	37,666	1,920	298,254		337,840
	803.04	21,878	245,229	821,644	554,576	1,643,327
	Census Tract Total	61,632	381,486	1,203,667	554,576	2,201,361
804	804.01		3,470		1,817	5,287
	804.02	2,796	11,596		396	14,788
	804.03	24,700	6,614		16,934	48,248
	804.04	70,517	3,393			73,910
	804.05	41,299	117,659	88,730	93,520	341,208
	Census Tract Total	139,312	142,732	88,730	112,667	483,441
805	805.01	203,007	32,436			235,443
	805.02	324,873	8,533	90,700		424,106
	805.03	71,248	250,923		10,987	333,158
	Census Tract Total	599,128	291,892	90,700	10,987	992,707
808 2/	808.01	137,857	737,097	79,568	1,010,873	1,965,395
	Census Tract Total	137,857	737,097	79,568	1,010,873	1,965,395
809 2/	809.01	305,855	782,134	581,666	3,356,487	5,026,142
	Census Tract Total	305,855	782,134	581,666	3,356,487	5,026,142
810	810.01	105,210	113,252		174,678	393,140
	Census Tract Total	105,210	113,252		174,678	393,140
811	811.01				275,277	275,277
	811.02	11,629	289,860			301,489
	811.04	86,128	104,703		20,090	210,921
	Census Tract Total	97,757	394,563		295,367	787,687
812	812.01	85,064		380,201	3,865,610	4,330,875
	Census Tract Total	85,064		380,201	3,865,610	4,330,875

(CONTINUED)



Nonresidential Structure Gross Floor Area by General Activity  
Census and Subcensus Tract  
(January 1995)

Census Tract	Subcensus Tract	Activity Type				Total Gross Floor Area
		Institutional	Commercial Retail	Industrial	Commercial Office	
814	814.01	161,345	155,257			316,602
	Census Tract Total	161,345	155,257			316,602
815	815.01	62,131				62,131
	Census Tract Total	62,131				62,131
816	816.01	13,252				13,252
	816.02	18,884				18,884
	Census Tract Total	32,136				32,136
817	817.01	11,940				11,940
	817.02	2,080				2,080
	817.03	2,250				2,250
	Census Tract Total	16,270				16,270
819	819.01	148,007	79,908	220,329	1,534,676	1,982,920
	819.02	23,880				23,880
	Census Tract Total	171,887	79,908	220,329	1,534,676	2,006,800
820	820.01	114,911	3,814			118,725
	820.02	102,931				102,931
	Census Tract Total	217,842	3,814			221,656
821	821.01	9,979	48,207		80,101	138,287
	Census Tract Total	9,979	48,207		80,101	138,287
822	822.01	249,676	607,701	14,450	1,833,116	2,704,943
	822.02	22,150	968	460,713	877,593	1,361,424
	822.03	112,979			73,766	186,745
	Census Tract Total	384,805	608,669	475,163	2,784,475	4,253,112
823	823.01	407,966	370,111		1,451,076	2,229,153
	Census Tract Total	407,966	370,111		1,451,076	2,229,153
824	824.01	66,588		1,702	2,156,117	2,224,407
	Census Tract Total	66,588		1,702	2,156,117	2,224,407
825	825.01	52,334	692,230	1,567,981	1,930,306	4,242,851
	825.02	112,132	109,385	88,300	112,686	422,503
	Census Tract Total	164,466	801,615	1,656,281	2,042,992	4,665,354

(CONTINUED)

Nonresidential Structure Gross Floor Area by General Activity  
Census and Subcensus Tract  
(January 1995)

Census Tract	Subcensus Tract	Activity Type				Total Gross Floor Area
		Institutional	Commercial Retail	Industrial	Commercial Office	
826	826.01	139,500	625,657			765,157
	826.02	372,037	13,976		405,801	791,814
	Census Tract Total	511,537	639,633		405,801	1,556,971
901	901.01	2,100		297,584	147,888	447,572
	901.03	32,757	129,317	2,223,966	325,671	2,711,711
	901.04	25,270	283,214	2,372,646	1,267,606	3,948,736
	901.05	93,856	554,792	237,961	775,064	1,661,673
	901.06	8,133		300,000		308,133
	Census Tract Total	162,116	967,323	5,432,157	2,516,229	9,077,825
905	905.01	57,817	162,183		3,102	223,102
	905.02	96,601	69,009	1,515	62,074	229,199
	Census Tract Total	154,418	231,192	1,515	65,176	452,301
909 3/	909.01	24,699	18,966		19,927	63,592
	Census Tract Total	24,699	18,966		19,927	63,592
910	910.01	1,560				1,560
	910.02				9,484	9,484
	Census Tract Total	1,560			9,484	11,044
911	911.01	507,534				507,534
	Census Tract Total	507,534				507,534
912	912.01	9,434	138,693			148,127
	912.02		82,885		4,368	87,253
	Census Tract Total	9,434	221,578		4,368	235,380
913	913.01	526		14,835		15,361
	913.02	3,486		135,577		139,063
	913.03	3,600	9,072	69,234		81,906
	913.04	174,841	536,788		71,058	782,687
	Census Tract Total	182,453	545,860	219,646	71,058	1,019,017
914	914.01	304,772	192,985		73,435	571,192
	Census Tract Total	304,772	192,985		73,435	571,192
915	915.01	274,522				274,522

(CONTINUED)

Nonresidential Structure Gross Floor Area by General Activity  
Census and Subcensus Tract  
(January 1995)

Census Tract	Subcensus Tract	Activity Type				Total Gross Floor Area
		Institutional	Commercial Retail	Industrial	Commercial Office	
915	915.02	30,720	37,211		5,714	73,645
	915.03	3,108	13,267		37,404	53,779
	Census Tract Total	308,350	50,478		43,118	401,946
916	916.01	198,878	157,727	689,627	182,241	1,228,473
	Census Tract Total	198,878	157,727	689,627	182,241	1,228,473
917	917.01	7,485	493,808		1,314,283	1,815,576
	917.02	44,090	1,901,480		1,347,322	3,292,892
	917.03	180,229	6,848			187,077
	917.04	64,008	325,221	42,160	1,158,345	1,589,734
	Census Tract Total	295,812	2,727,357	42,160	3,819,950	6,885,279
918	918.01	487,890	866,170		734,375	2,088,435
	Census Tract Total	487,890	866,170		734,375	2,088,435
919	919.01	337,377				337,377
	919.05	77,770				77,770
	919.07	10,960				10,960
	919.09	5,456				5,456
	919.11	1,080				1,080
	Census Tract Total	432,643				432,643
920	920.01	70,625		2,722	3,360	76,707
	920.02	59,096	96,052	17,176		172,324
	920.03	8,000		6,248		14,248
	Census Tract Total	137,721	96,052	26,146	3,360	263,279
921	921.04				2,608	2,608
	921.05	21,457	3,840			25,297
	921.06	16,600	5,000			21,600
	921.07	11,666				11,666
	Census Tract Total	49,723	8,840		2,608	61,171
922	922.01	2,663				2,663
	922.02	2,450				2,450
	922.03	70,208	15,752	2,376		88,336

(CONTINUED)

Nonresidential Structure Gross Floor Area by General Activity  
Census and Subcensus Tract  
(January 1995)

Census Tract	Subcensus Tract	Activity Type				Total Gross Floor Area
		Institutional	Commercial Retail	Industrial	Commercial Office	
922	922.04	1,374	2,000			3,374
	922.05	82,595		2,952		85,547
	<b>Census Tract Total</b>	<b>159,290</b>	<b>17,752</b>	<b>5,328</b>		<b>182,370</b>
923	923.01	83,250				83,250
	<b>Census Tract Total</b>	<b>83,250</b>				<b>83,250</b>
924	924.01	7,552				7,552
	<b>Census Tract Total</b>	<b>7,552</b>				<b>7,552</b>
<b>Fairfax County Total</b>		<b>32,011,444</b>	<b>40,337,190</b>	<b>36,162,495</b>	<b>74,684,888</b>	<b>183,196,017</b>

Note: All data in square feet.

- 1/ Comprises part of the Town of Vienna (Vienna is composed of Census Tracts 607 through 610).
- 2/ Comprises part of the Town of Herndon (Herndon is composed of Census Tracts 808 and 809).
- 3/ Town of Clifton (Clifton is composed of Census Tract 909).

# IX. EXISTING LAND USE

## EXISTING LAND USE

### Zoned Land

Fairfax County, including the Towns of Herndon, Clifton, and Vienna, comprises approximately 262,400 acres. Of this total, 33,034 acres are in roads, water, and small areas of land that cannot be developed, while 229,366 acres are classified into various zoning categories – 224,515 acres in County zoning categories and 4,851 acres in zoning categories associated with the Towns of Herndon, Clifton, and Vienna.

The lists of zoning codes that are used by the County and the towns within the County are included on pages IX-7 and IX-9, respectively. The County zoning codes reflect the zoning districts established in the Fairfax County Zoning Ordinance that went into effect in August 1978. A complete description, as well as the development requirements associated with each zoning district, is available in the Fairfax County Zoning Ordinance. Zoning ordinances for the Towns of Herndon, Clifton, and Vienna contain descriptions of town zoning districts.

Most of the land in Fairfax County is zoned for residential development as is shown in Figure 9.1 and Table 9.3. Of the 229,366 acres under the County's and the towns' zoning ordinances, 210,616 acres or 91.8 percent is zoned for residential or residential-related use. Industrial zoned acreage accounts for 10,340 acres or 4.5 percent of the County's zoned acreage. The smallest zoned acreage is commercial related, accounting for 8,410 acres or 3.7 percent of the County's zoned acreage.

The Pohick Planning District contains the largest percentage of residential zoned acreage at 21.6 percent or 45,410 acres. The Bull Run Planning District contains the largest percentage of industrial zoned acreage at 31.7 percent or 3,280 acres. Finally, the Upper Potomac Planning District contains the largest percentage of commercial zoned acreage at 14.9 percent or 1,254 acres.

### Zoned Vacant Land

Figure 9.1 and Table 9.4 show the County's vacant acreage by major zoning categories. Approximately 16.1 percent or 37,006 acres of land zoned under the County's Zoning Ordinance is vacant, a decline of

17.8 percent since 1990. Approximately 83.0 percent of the currently vacant land, or 30,727 acres is zoned for residential development. Vacant land that is zoned for commercial use totals 1,998 acres while vacant land that is zoned for industrial use totals 4,281 acres.

The combined Bull Run, Pohick, and Upper Potomac Planning Districts account for 64.7 percent (23,957 acres) of zoned vacant land in the County while the combined Annandale, Baileys, Jefferson, and Lincolnia Planning Districts have only 2.9 percent (1,070 acres) of the County's zoned vacant land.

As shown in Table 9.1, Total vacant acreage has dropped to 37,006 acres (16.1 percent of all developable acres) in 1995 from 45,042 acres (19.5 percent of developable acres) in 1990 and 75,550 acres (32.2 percent of developable acres) in 1980.

TABLE 9.1

Vacant Acres in Fairfax County  
1980, 1985, 1990 and 1995

Year	Vacant Acres	Total Developable Acres	Percent of Total Acreage
1980	75,550	234,744	32.2%
1985	66,685	232,941	29.2%
1990	45,042	230,678	19.5%
1995	37,006	229,366	16.1%

Note: Total Developable Acres does not include areas in roads, water, or small areas of undevelopable land.

## Land Use

Table 9.2 and Figure 9.2 show acres of land by existing general land use category for all areas of the County including towns. A total of 121,333 acres, or 52.9 percent of the County's land is currently used for residential purposes, and 38,454 acres, or 16.8 percent of the County's land is vacant or in natural uses. Parks and Recreation uses account for 26,716 acres, or 11.6 percent of the available land in the County, while Industrial use accounts for 8,839 acres, or 3.9 percent. Commercial/Retail use accounts for only 8,801 acres, or 3.8 percent of the total usable land in Fairfax County.

TABLE 9.2

Acres of Land by General Land Use Category  
January 1995

<b>Land Use Category</b>	<b>Acres</b>	<b>Percent of Total</b>
Residential	121,333	52.9%
Industrial	8,839	3.9%
Commercial / Retail	8,801	3.8%
Parks and Recreation	26,716	11.6%
Public	25,227	11.0%
Vacant and Natural Uses	38,454	16.8%
<b>Fairfax County</b>	<b>229,366</b>	<b>100.0%</b>

Note: Figures may not sum to total due to rounding.

Figure 9.1

# Land Acreage by Major Zoning Class

Fairfax County, January 1995

---

*Total Acreage*

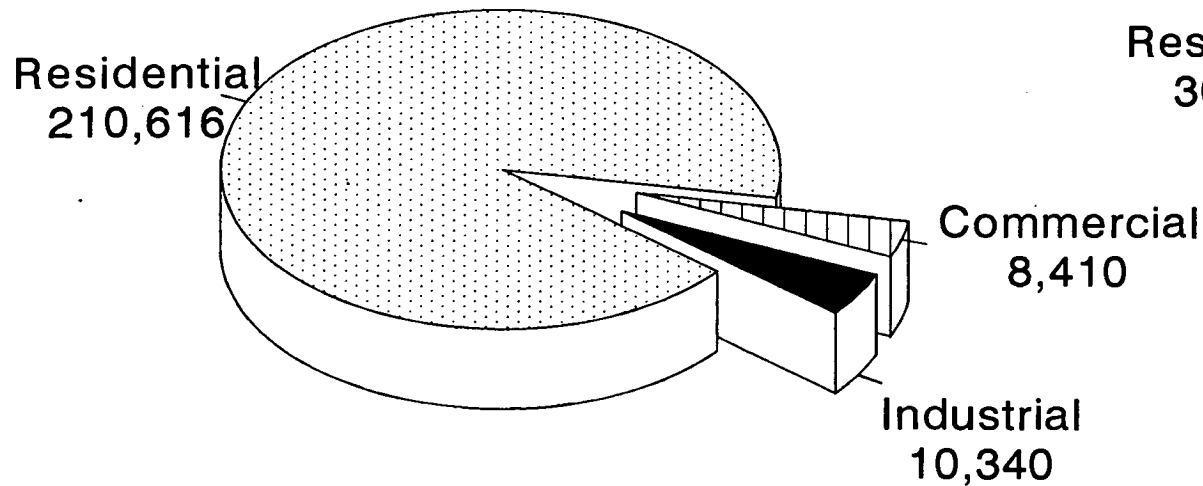

*Vacant Acreage*

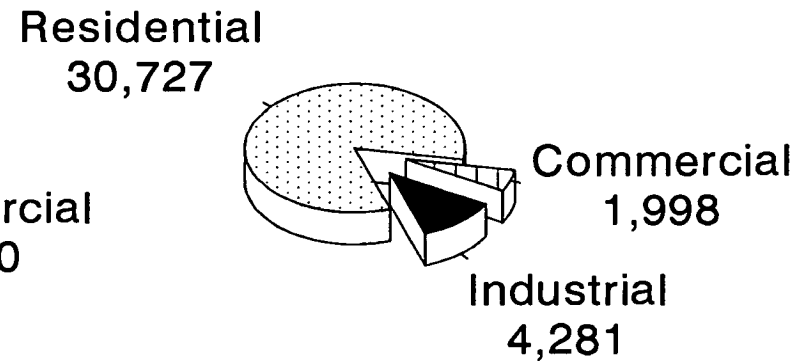

Source: Fairfax County Office of Management and Budget.



Table 9.3

Total Acres by Major Zoning Class  
Fairfax County, January 1995

Planning District	Residential		Commercial		Industrial		TOTAL	
	Acres	Percent	Acres	Percent	Acres	Percent	Acres	Percent
Annandale	9,201	4.4	306	3.6	578	5.6	10,085	4.4
Baileys	2,979	1.4	445	5.3	11	0.1	3,435	1.5
Bull Run	24,626	11.7	1,205	14.3	3,280	31.7	29,111	12.7
Fairfax	10,395	4.9	874	10.4	201	1.9	11,470	5.0
Jefferson	4,041	1.9	751	8.9	388	3.8	5,180	2.3
Lincolnia	1,383	0.7	158	1.9	191	1.8	1,732	0.8
Lower Potomac	22,533	10.7	188	2.2	904	8.7	23,625	10.3
McLean	15,369	7.3	929	11.0	168	1.6	16,466	7.2
Mount Vernon	10,972	5.2	881	10.5	10	0.1	11,863	5.2
Pohick 1/	45,410	21.6	229	2.7	101	1.0	45,740	19.9
Rose Hill	7,675	3.6	240	2.9	266	2.6	8,181	3.6
Springfield	7,008	3.3	388	4.6	1,491	14.4	8,887	3.9
Upper Potomac 2/	39,510	18.8	1,254	14.9	2,527	24.4	43,291	18.9
Vienna 3/	9,514	4.5	562	6.7	224	2.2	10,300	4.5
TOTAL	210,616	100.0	8,410	100.0	10,340	100.0	229,366	100.0

- 1/ Includes the Town of Clifton.  
2/ Includes the Town of Herndon.  
3/ Includes the Town of Vienna.

Table 9.4

Acres of Vacant Land by Major Zoning Class  
Fairfax County, January 1995

Planning District	Residential		Commercial		Industrial		TOTAL	
	Vacant Land		Vacant Land		Vacant Land		Vacant Land	
	Acres	Percent	Acres	Percent	Acres	Percent	Acres	Percent
Annandale	292	1.0	7	0.4	60	1.4	359	1.0
Baileys	140	0.5	25	1.3	1	0.0	166	0.4
Bull Run	6,387	20.8	436	21.8	1,857	43.4	8,680	23.5
Fairfax	1,352	4.4	275	13.8	95	2.2	1,722	4.7
Jefferson	124	0.4	157	7.9	22	0.5	303	0.8
Lincolnia	199	0.6	18	0.9	25	0.6	242	0.7
Lower Potomac	3,127	10.2	100	5.0	519	12.1	3,746	10.1
McLean	1,719	5.6	196	9.8	18	0.4	1,933	5.2
Mount Vernon	738	2.4	115	5.8			853	2.3
Pohick 1/	7,025	22.9	39	2.0	10	0.2	7,074	19.1
Rose Hill	1,073	3.5	122	6.1	73	1.7	1,268	3.4
Springfield	1,186	3.9	59	3.0	381	8.9	1,626	4.4
Upper Potomac 2/	6,600	21.5	403	20.2	1,200	28.0	8,203	22.2
Vienna 3/	765	2.5	46	2.3	20	0.5	831	2.2
TOTAL	30,727	100.0	1,998	100.0	4,281	100.0	37,006	100.0

- 1/ Includes the Town of Clifton.  
2/ Includes the Town of Herndon.  
3/ Includes the Town of Vienna.

Figure 9.2

# Acres of Land by Land Use

Fairfax County, January 1995

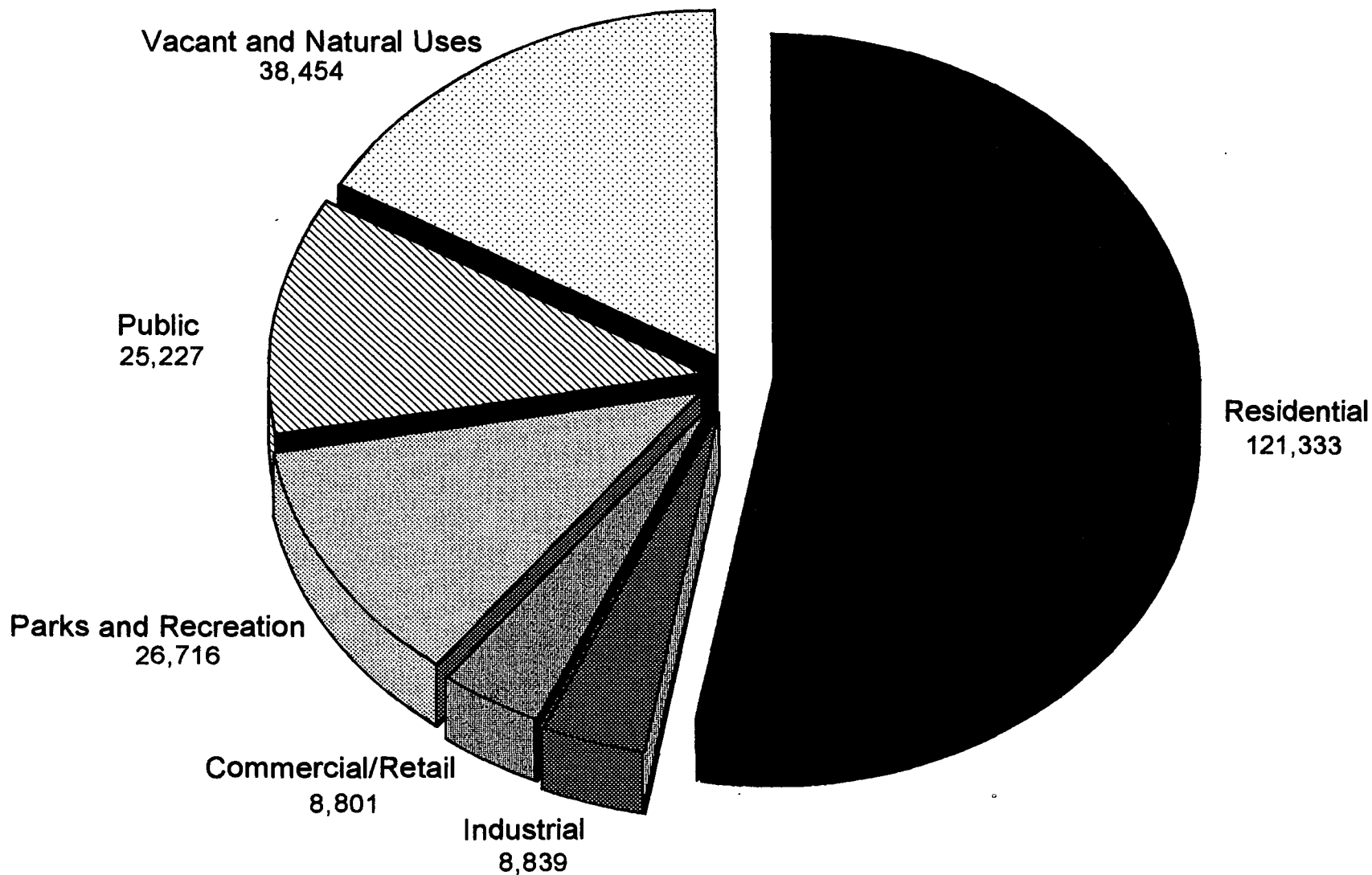

Note: Land in the towns of Vienna, Herndon and Clifton is included in this chart.

TABLE 9.5

## Fairfax County Zoning Codes

<u>CODE</u>	<u>ZONING DESIGNATION</u>	<u>AGRICULTURAL - CONSERVATION</u>
010	R-P	(Residential Preservation)
020	R-A	(Rural Agricultural)
030	R-C	(Residential Conservation)
096	P AG	Predominately agricultural or conservation but contains a mixture of other agricultural or conservation zonings.
097	P AG-R	Predominately agricultural or conservation but contains a mixture of other residential zonings including apartments.
098	P AG-C	Predominately agricultural or conservation but contains a mixture of commercial and/or industrial zonings.
099	P AG-N	Predominately agricultural or conservation but contains a mixture of zoning categories.

<u>CODE</u>	<u>ZONING DESIGNATION</u>	<u>RESIDENTIAL</u>
<u>Attached and Detached</u>		
100	R-E	(Residential Estate)
101	R-EC	(Residential Estate Cluster Development <sup>1</sup> )
110	R-1	(Residential - 1 Dwelling Unit Per Acre)
111	R-1C	(R-1 with cluster development)
120	R-2	(Residential - 2 Dwelling Units Per Acre)
121	R-2C	(R-2 with cluster development)
130	R-3	(Residential - 3 Dwelling Units Per Acre)
131	R-3C	(R-3 with cluster development)
140	R-4	(Residential - 4 Dwelling Units Per Acre)
141	R-4C	(R-4 with cluster development)
150	R-5	(Residential - 5 Dwelling Units Per Acre)
151	R-5C	(R-5 with cluster development)
180	R-8	(Residential - 8 Dwelling Units Per Acre)
181	R-8C	(R-8 with cluster development)
196	P RES	Predominately residential detached and attached but contains a mixture of other residential zonings.
197	P RES-MF	Predominately residential detached and attached but contains some multi-family zoning.
198	P RES-C	Predominately residential detached and attached but contains a mixture of commercial and/or industrial zoning.
199	P RES-N	Predominately residential detached and attached but contains a mixture of other zonings not elsewhere classified.

<u>Multi-Family</u>		
206	R-MHP	(Residential Mobile Home Park)
212	R-12	(Residential - 12 Dwelling Units Per Acre)
213	R-12C	(R-12 with cluster development)
216	R-16	(Residential - 16 Dwelling Units Per Acre)
220	R-20	(Residential - 20 Dwelling Units Per Acre)
230	R-30	(Residential - 30 Dwelling Units Per Acre)
295	P MH	Predominately mobile home but contains a mixture of other zoning categories.
296	P MF	Predominately multi-family but contains a mixture of other multi-family zonings.
297	P MF-R	Predominately multi-family but contains a mixture of other residential zonings.
298	P MF-C	Predominately multi-family but contains a mixture of commercial and/or industrial zonings.
299	P MF-N	Predominately multi-family but contains a mixture of other zonings not elsewhere classified.

<u>Planned Development Housing (PDH)</u>		
301	PDH-1	(Residential - 1 Dwelling Unit Per Acre)
302	PDH-2	(Residential - 2 Dwelling Units Per Acre)
303	PDH-3	(Residential - 3 Dwelling Units Per Acre)
304	PDH-4	(Residential - 4 Dwelling Units Per Acre)
305	PDH-5	(Residential - 5 Dwelling Units Per Acre)
308	PDH-8	(Residential - 8 Dwelling Units Per Acre)
312	PDH-12	(Residential - 12 Dwelling Units Per Acre)
316	PDH-16	(Residential - 16 Dwelling Units Per Acre)

<sup>1</sup> Cluster development refers to a subdivision development pattern in which units are grouped or "clustered," resulting in smaller individual lot sizes and a larger common area.

ZONING DESIGNATION		RESIDENTIAL (continued)
<u>Planned Development Housing (PDH)</u>		
320	PDH-20	(Residential - 20 Dwelling Units Per Acre)
330	PDH-30	(Residential - 30 Dwelling Units Per Acre)
340	PDH-40	(Residential - 40 Dwelling Units Per Acre)
370	PRC-GC	(General Combination Development)
371	PRC-OS	(Open Space)
372	PRC-R	(Residential Development)
373	PRC-C/I	(Commercial and/or Industrial Development)
374	PRC-CF	(Community Facilities)
396	P PDH	Predominately PDH but contains a mixture of PDH zonings.
397	P PDH-R	Predominately PDH but contains other residential zonings including apartments.
398	P PDH-C	Predominately PDH but contains a mixture of commercial and/or industrial zonings.
399	P PDH-N	Predominately PDH but contains a mixture of zoning categories not elsewhere classified.

ZONING DESIGNATION		COMMERCIAL - OFFICE - RETAIL
400	PDC	(Planned Development Commercial)
401	PDC-OS	(Open Space)
402	PDC-R	(Residential Development - not rental)
403	PDC-C/I	(Commercial/Industrial/Rental)
404	PDC-CF	(Community Facilities)
410	C-1	(Lowrise Office Transitional)
420	C-2	(Limited Office)
430	C-3	(Office)
440	C-4	(High Density Office)
450	C-5	(Neighborhood Retail)
460	C-6	(Community Retail)
470	C-7	(Regional Retail)
480	C-8	(Highway Commercial)
496	P COM	Predominately commercial but contains a mixture of commercial zonings.
497	P COM-R	Predominately commercial but contains some residential zonings including apartments.
498	P COM-I	Predominately commercial but contains some industrial zonings.
499	P COM-N	Predominately commercial but contains a mixture of zonings not elsewhere classified.

ZONING DESIGNATION		INDUSTRIAL
500	I-I	(Industrial Institutional)
510	I-1	(Industrial Light Research)
520	I-2	(Industrial Research)
530	I-3	(Industrial Light Intensity)
540	I-4	(Industrial Medium Intensity)
550	I-5	(Industrial General)
560	I-6	(Industrial Heavy)
596	P IND	Predominately industrial but contains a mixture of industrial zonings.
597	P IND-R	Predominately industrial but contains residential zonings, including apartments.
598	P IND-C	Predominately industrial but contains some commercial zonings.
599	P IND-N	Predominately industrial but contains a mixture of zonings not elsewhere classified.

TABLE 9.6

Zoning Codes for Towns within Fairfax County

<u>CODE</u>	<u>ZONING DESIGNATION</u>	<u>TOWN OF CLIFTON</u>
700	CL-AGRI	General Agriculture
710	CL-RESID	General Residential (Minimum Lot Size 10,000 Square Feet)
740	CL-COML	General Commercial (Retail and Office Use)
750	CL-IND	General Industrial (Manufacturing and Storage Use)

<u>CODE</u>	<u>ZONING DESIGNATION</u>	<u>TOWN OF HERNDON</u>
800	H-RPC	(Residential Planned Community)
801	H-PDH	(Planned Development Housing)
802	H-SF.SAC	(Single Family - 21,780 Square Feet/Lot) 2 Dwelling Units
803	H-SF15	(Single Family - 15,000 Square Feet/Lot) 2-Plus Dwelling Units
804	H-SF10	(Single Family - 10,000 Square Feet/Lot) 3-Plus Dwelling Units
805	H-RTH5	(Residential Townhouse - 5 Units/Acre)
806	H-RGC	(Residential Garden Court - 6 Units/Acre)
810	H-RTH10	(Residential Townhouse - 10 Units/Acre)
820	H-RMF20	(Multifamily - 20 Units/Acre)
821	H-MF20	(Multifamily - 20 Units/Acre with Some Offices and Shops)
845	PD-MU	(Planned Development - Mixed Use)
846	PD-C	(Planned Development - Commercial)
847	PD-CI	(Planned Development - Commercial and Industrial)
850	H-PD-SC	(Planned Development - Shopping Center)
851	H-COMRET	(General Commercial - Retail Shopping and Personal Service - 2,500 Square Feet Limit on any Specific Shop)
852	H-COMVAR	(General Commercial - Variety Business Commercial and Miscellaneous Services)
853	H-CENCOM	(Central Commercial - Shopping and Office Core of Central Business District Similar to C-2 but with Altered Side Yard and Parking Requirements)
854	C-3	(Commercial Service District)
858	H-COMOFC	(Commercial Office - Office Uses Ordinarily Between Residential and Commercial Areas)
860	H-PD-IP	(Planned Development - Industrial Park)
861	PD-IG	(Planned Development - Industrial General)
862	H-IR	(Industrial Research - Light Industrial, Office, and Commercial Activities)
863	H-I-P	(Industrial Park)
864	I-O	(Industrial Office)
865	I-M	(Industrial Medium)
866	H-I-G	(Industrial General - Heavy Industrial)
890	H-PRES	Predominately residential but contains other zone classes or combinations of residential zone classes.
892	H-PMF	Predominately multifamily but contains other zone classes or combinations of multifamily zone classes.
895	H-PCOML	Predominately commercial but contains other zone classes or combinations of commercial zone classes.
896	H-PIND	Predominately industrial but contains other zone classes or combinations of industrial zone classes.

<u>CODE</u>	<u>ZONING DESIGNATION</u>	<u>TOWN OF VIENNA</u>
902	V-SF16	(16,000 Square Feet/Lot) 2 Dwelling Units
903	V-SF12.5	(12,000 Square Feet/Lot) 2.6 Dwelling Units
904	V-SF10	(10,000 Square Feet/Lot) 3.2 Dwelling Units
908	V-RTH5/8	(Under 5 Acres - 8 Units/Acre)
910	V-RTH5/10	(5 Acres and Over - 10 Units/Acre)
920	V-MFAPT	(Multifamily Apartments)
950	V-LOCCOM	(Local Commercial)
951	V-SPCCOM	(Special Commercial)
953	V-GENCOM	(General Commercial)
960	V-INDPK	(Industrial Park)
961	V-LTDIND	(Limited Industrial)
990	V-TRANS	(Transitional)
991	V-PRES	Predominately residential but contains other zone classes or combinations of residential zones.
992	V-PMF	Predominately multifamily but contains other zone classes or combinations of multifamily zones.
995	V-PCOML	Predominately commercial but contains other zone classes or combinations of commercial zones.
996	V-PIND	Predominately industrial but contains other zone classes or combinations of industrial zones.

Acres of Land by Zoning Class  
Supervisor District  
(JANUARY 1995)

Zoning Class	Braddock		Dranesville 1/		Hunter Mill 2/		Lee		Mason		Mount Vernon		Providence		Springfield 3/		Sully		COUNTY TOTAL	
	Total Acres	Vacant Acres	Total Acres	Vacant Acres	Total Acres	Vacant Acres	Total Acres	Vacant Acres	Total Acres	Vacant Acres	Total Acres	Vacant Acres	Total Acres	Vacant Acres	Total Acres	Vacant Acres	Total Acres	Vacant Acres	Total Acres	Vacant Acres
R-A			107	10	65	9					24	24					21	5	217	48
R-C	324	242			5						11,171				27,014	5,235	11,580	4,666	50,094	10,143
P AG-R														116	96	80	20	196	116	
P AG-C																				
R-E	19		14,389	3,073	2,456	409					9,007	2,092	75	14	237	140	1,055	223	27,238	5,951
R-EC			424	12	310	2											165		899	14
R-1	1,892	121	8,921	1,664	3,652	749	4,022	505	808	40	3,402	1,643	4,549	715	3,915	506	8,837	1,578	39,998	7,521
R-1C	44		1,672	118	1,626	66							521	9	388	83	1,117	162	5,368	438
R-2	1,393	79	2,119	200	612	35	996	129	3,979	322	4,201	288	847	76	303	16	549	145	14,999	1,290
R-2C	1,884	2	808	13	1,296	4	43	1	258	1	332	9	364	2	743	1	600	38	6,328	71
R-3	2,497	34	2,214	140	539	57	3,492	352	2,648	147	2,856	174	1,466	97	1,339	69	901	57	17,952	1,127
R-3C	1,022	4	667	7	389	47	563	5	150	1	52		229	6	1,972	33	2,003	17	7,047	120
R-4	131	3	942	37	2		1,208	115	956	9	765	36	1,146	54					5,150	254
R-4C							11				7		45	9	23				86	9
R-5	75		26	2	5		653	4	97	1	182	30	125	5	337	5	483	9	1,983	56
R-5C	82		6				121	7	5				62		380		45		701	7
R-8	93		52	1	41	13	335	29	50	4	296	9	98	7	84	4	592	36	1,641	103
R-8C	147	1	134		4		103		20		59		147		109		54	3	777	4
P RES	336	8	32	14	161	20	83	60	5	1	3		101		137	25	73	6	931	134
P RES-MF							2						5	3			3	3	10	6
P RES-C					33		2				238	94			1		609		883	94
R-MHP	26						84												110	
R-12	45		12	2			61	31	125	28	93	51	150	22	20		16		522	134
R-12C	19		11						72	1			130		11				243	1
R-16			6	1			9	4	6				9				1		31	5
R-20	318	6	25		61		476	13	392		307	13	664	5	46		160		2,449	37
R-30			32	8			13		101	1	82		95	8					323	17

(CONTINUED)

- 1/ Excludes the Town of Herndon.
- 2/ Excludes the Town of Vienna.
- 3/ Excludes the Town of Clifton.

Acres of Land by Zoning Class  
Supervisor District  
(JANUARY 1995)

Zoning Class	Braddock		Dranesville 1/		Hunter Mill 2/		Lee		Mason		Mount Vernon		Providence		Springfield 3/		Sully		COUNTY TOTAL	
	Total Acres	Vacant Acres	Total Acres	Vacant Acres	Total Acres	Vacant Acres	Total Acres	Vacant Acres	Total Acres	Vacant Acres	Total Acres	Vacant Acres	Total Acres	Vacant Acres	Total Acres	Vacant Acres	Total Acres	Vacant Acres	Total Acres	Vacant Acres
P MF			15						29											44
P MF-R							6				36		21					13		76
P MF-C									2											2
PDH-1	1		139	19	199	45					100				377	4			816	68
PDH-2	2	1	21	4	111	106					63	10	51	7	866	102	1,814	220	2,928	450
PDH-3	549		24		30	29					1,105	19	145	50	853	13	987	96	3,693	207
PDH-4	47		14				1,102	417			85	14	121	10	8		506	35	1,883	476
PDH-5	9		47		47		97	26	20		69	20	14		39		164	84	506	130
PDH-8					24	24	269	109	105	1	4	4	279	21			213	17	894	176
PDH-12			13		15	15	39						82		17		331	28	497	43
PDH-16					229	168	60	49	19		46	1	26				71	41	451	259
PDH-20	2		56	2	25	25	5	5	14	1			124	3			164	63	390	99
PDH-30																	7	7	7	7
PDH-40			10								9		5	5					24	5
PRC-GC	251				3,046	40	165	3							1,044	79			4,506	122
PRC-OS	4				362														366	
PRC-R	326		111	45	1,405	99			3						256	2			2,101	146
PRC-C/I	24				679	288									23		35		761	288
PRC-CF					65														65	
P PDH																	64	26	64	26
P PDH-R	2				5	5											45		52	5
P PDH-C					82	82	248	223											330	305
PDC			1	1	303	214	77	60	46	11			300	81			454	188	1,181	555
PDC-OS																	10	10	10	10
PDC-R							16	2	52				56				256	31	380	33
PDC-C/I									7				335	103			412	219	754	322
PDC-CF									11										11	

(CONTINUED)

- 1/ Excludes the Town of Herndon.
- 2/ Excludes the Town of Vienna.
- 3/ Excludes the Town of Clifton.



Acres of Land by Zoning Class  
Supervisor District  
(JANUARY 1995)

Zoning Class	Braddock		Dranesville 1/		Hunter Mill 2/		Lee		Mason		Mount Vernon		Providence		Springfield 3/		Sully		COUNTY TOTAL	
	Total Acres	Vacant Acres	Total Acres	Vacant Acres	Total Acres	Vacant Acres	Total Acres	Vacant Acres	Total Acres	Vacant Acres	Total Acres	Vacant Acres	Total Acres	Vacant Acres	Total Acres	Vacant Acres	Total Acres	Vacant Acres	Total Acres	Vacant Acres
C-1									3				1		4		1		9	
C-2	28		46				43	19	71	3	58	49	53	7	9		12	12	320	90
C-3	16	1	18	4	56	3	19	12	68	5	56	14	535	170			51	4	819	213
C-4			1				3		6	4	1		166	36			9		186	40
C-5	3		23	3	4		44	5	70	5	39	8	40		14		18	1	255	22
C-6	61	13	82	3	45		308	14	250	4	72	28	113	4	100		189	44	1,220	110
C-7					88		130	16	56				117	22			192	5	583	43
C-8	33	2	50		30	22	245	23	174	18	351	75	104	11	1		305	148	1,293	299
P COM	4		13				10	2	52		27	17	55	19			18	2	179	40
P COM-R	23		303	21	44	3	51	7	28	4	106	26	115	3	16		48	20	734	84
P COM-I							46	46	11		18						13	2	88	48
P COM-N													8	8					8	8
I-I			43	15			61	35											104	50
I-1			8						15	15									23	15
I-2					25	9	9												34	9
I-3	12		4		225	34	8	7	24		1	1	121				1,159	832	1,554	874
I-4	41	1	25	18	728	365	316	55	18	6	224	122	156	10	29	6	198	137	1,735	720
I-5	126	16	22	11	220	101	639	174	133	4	83	31	319	33	6		1,938	1,006	3,486	1,376
I-6	28	3					57	14	174	11	677	317	1				48	7	985	352
P IND	11				26	21	39	31	62	19	88	83	55	3			560	239	841	396
P IND-R	57	6			7		201	51	145	1	236	44	11				228	129	885	231
P IND-C					52	52			12	12							55	55	119	119
P IND-N									17				4				54	37	75	37
<b>TOTAL</b>	<b>12,007</b>	<b>543</b>	<b>33,688</b>	<b>5,448</b>	<b>19,434</b>	<b>3,161</b>	<b>16,590</b>	<b>2,660</b>	<b>11,369</b>	<b>680</b>	<b>36,631</b>	<b>5,346</b>	<b>14,361</b>	<b>1,638</b>	<b>40,837</b>	<b>6,419</b>	<b>39,586</b>	<b>10,713</b>	<b>224,503</b>	<b>36,608</b>

1/ Excludes the Town of Herndon.  
2/ Excludes the Town of Vienna.  
3/ Excludes the Town of Clifton.

Acres of Land by Zoning Class  
Planning District  
(JANUARY 1995)

Zoning Class	Annandale		Baileys		Bull Run		Fairfax		Jefferson		Lincolnia		Lower Potomac		McLean	
	Total Acres	Vacant Acres	Total Acres	Vacant Acres	Total Acres	Vacant Acres	Total Acres	Vacant Acres	Total Acres	Vacant Acres	Total Acres	Vacant Acres	Total Acres	Vacant Acres	Total Acres	Vacant Acres
R-A													24	24	65	9
R-C					11,580	4,666	324	242					11,171			
P AG-R					80	20										
P AG-C																
R-E					27		841	159					9,006	2,091	1,911	339
R-EC							165								33	2
R-1	743	29			5,154	1,116	4,887	650	616	34	63	2	1,606	923	6,228	932
R-1C					88	1	964	23							889	68
R-2	2,943	180	1,038	18	188	58	811	66	261	3	845	182	1	1	1,945	194
R-2C	754	2			540	8	628	2	23						788	13
R-3	2,901	60	1,459	104	702	55	361	12	873	35	11	1	92	4	1,785	74
R-3C	397	1	101		1,533	7	133		65	2					40	
R-4	360	8	5	1			9	4	1,624	35	129		1		942	37
R-4C																
R-5	96	1			276	9	70		15	1	21		119	17	26	2
R-5C	46				45		41		7						6	
R-8	24	1	21	3	575	20	22	16	22		5		105	4	52	1
R-8C	50	1			54	3	1		28				44		61	
P RES	285		1		61	6	85	8	18	1			2		32	14
P RES-MF					3	3	2									
P RES-C					609								144			
R-MHP							26									
R-12	31		35	11	16		27		37	2	60	15	77	51	12	2
R-12C	74	1	4				54		3		13					
R-16			6		1				9						6	1
R-20	313	6	207		160		220		341		112		95	11	149	5
R-30	6		89	1							6				127	16

(CONTINUED)

- 1/ Excludes the Town of Clifton.
- 2/ Excludes the Town of Herndon.
- 3/ Excludes the Town of Vienna.

Acres of Land by Zoning Class  
Planning District  
(JANUARY 1995)

Zoning Class	Annandale		Baileys		Bull Run		Fairfax		Jefferson		Lincolnia		Lower Potomac		McLean	
	Total Acres	Vacant Acres	Total Acres	Vacant Acres	Total Acres	Vacant Acres	Total Acres	Vacant Acres	Total Acres	Vacant Acres	Total Acres	Vacant Acres	Total Acres	Vacant Acres	Total Acres	Vacant Acres
P MF	29															15
P MF-R					13		11									10
P MF-C			2													
PDH-1															121	10
PDH-2	2	1			990	189	9		27	6						15
PDH-3	116				648	68			19							24
PDH-4					495	24	103	14								14
PDH-5							103	80			20					47
PDH-8	8				187	17	306	21			97	1				
PDH-12					322	18	13	10	2							13
PDH-16	19				14		57	41	26				46	1		
PDH-20			14	1	148	63	123	3	17							
PDH-30					7	7										
PDH-40									5	5						10
PRC-GC																
PRC-OS																
PRC-R									3							
PRC-C/I																
PRC-CF																
P PDH					64	26										
P PDH-R	2				45											
P PDH-C																
PDC			46	11	171	99	351	78	21	11					109	44
PDC-OS					10	10										
PDC-R	3		30		248	31	8		62		12					
PDC-C/I			3		306	113	106	106	339	103						
PDC-CF			11													

(CONTINUED)

- 1/ Excludes the Town of Clifton.
- 2/ Excludes the Town of Herndon.
- 3/ Excludes the Town of Vienna.

Acres of Land by Zoning Class  
Planning District  
(JANUARY 1995)

Zoning Class	Annandale		Baileys		Bull Run		Fairfax		Jefferson		Lincolnia		Lower Potomac		McLean	
	Total Acres	Vacant Acres	Total Acres	Vacant Acres	Total Acres	Vacant Acres	Total Acres	Vacant Acres	Total Acres	Vacant Acres	Total Acres	Vacant Acres	Total Acres	Vacant Acres	Total Acres	Vacant Acres
C-1	2		1		1											
C-2	51	1	15	1	12	12	18	4	6	1	8		49	49	44	
C-3	41	3	30	2	1		95	63	85	22	8	1			339	91
C-4			2				9		26		4	4	1		123	34
C-5	11	1	31	1	17		15	1	31	3	8		10	4	21	
C-6	135	2	63	2	142	29	54		59	1	70		4	2	64	2
C-7			56		58	3	134	1	8						94	22
C-8	30	1	123	5	183	125	48	5	73	7	20	11	99	39	28	2
P COM	13		16		16		5	2	9	6	28				17	
P COM-R	6	1	18	2	39	13	16	8	31	3	2	1	7	6	89	1
P COM-I	11				1		6	1					18			
P COM-N							8	8								
I-I															43	15
I-1											15	15			8	
I-2																
I-3			11		1,143	816	33		54		14		1	1	4	
I-4	41	1			198	137	17		64	10	18	6	196	114	67	
I-5	75	6	1	1	1,106	536	137	93	211	11	109	3	46	18	43	3
I-6	202	14			42				1				385	265		
P IND	38	19			463	147	5	2	50	1	34		88	83		
P IND-R	193	7			219	129	9		8				186	37	3	
P IND-C	12	12			55	55										
P IND-N	17				54	37										
TOTAL	10,080	359	3,439	164	29,110	8,676	11,470	1,723	5,179	303	1,732	242	23,623	3,745	16,462	1,933

(CONTINUED)

- 1/ Excludes the Town of Clifton.
- 2/ Excludes the Town of Herndon.
- 3/ Excludes the Town of Vienna.

Acres of Land by Zoning Class  
Planning District  
(JANUARY 1995)

Zoning Class	Mount Vernon		Pohick 1/		Rose Hill		Springfield		Upper Potomac 2/		Vienna 3/		COUNTY TOTAL	
	Total Acres	Vacant Acres	Total Acres	Vacant Acres	Total Acres	Vacant Acres	Total Acres	Vacant Acres	Total Acres	Vacant Acres	Total Acres	Vacant Acres	Total Acres	Vacant Acres
R-A									128	15			217	48
R-C			27,014	5,235							5		50,094	10,143
P AG-R			116	96									196	116
P AG-C														
R-E	1	1	256	140					14,760	3,173	435	48	27,237	5,951
R-EC									608	12	92		898	14
R-1	398	1	5,319	1,109	2,124	89	2,309	592	7,679	1,629	2,871	414	39,997	7,520
R-1C			432	83					2,366	259	629	4	5,368	438
R-2	4,615	343	476	20	208	13	397	60	790	101	482	51	15,000	1,290
R-2C	332	9	1,589	2	35		8	1	899	30	731	5	6,327	72
R-3	3,109	193	1,186	83	2,334	273	1,361	52	945	115	834	66	17,953	1,127
R-3C	87		2,557	36	425	5	140		1,453	63	116	5	7,047	119
R-4	1,032	106	6		492	39	449	7			102	17	5,151	254
R-4C	7		23					11			45	9	86	9
R-5	30		367	5	447	4	237	13	207		73	4	1,984	56
R-5C			422		86	7	34				14		701	7
R-8	297	5	161	2	124	27	120	3	13		99	19	1,640	101
R-8C	31		226		32		55		73		122		777	4
P RES	1		160	25	40	33	44	27	51	20	152		932	134
P RES-MF	2										3	3	10	6
P RES-C	1	1	1					95	93		33		883	94
R-MHP	84												110	
R-12	54	26	50		3	3	21	3			100	22	523	135
R-12C			11						11		74		244	1
R-16	4	4			5								31	5
R-20	634	13	79		14		40	1	23		62		2,449	36
R-30	79				13			3					323	17

(CONTINUED)

- 1/ Excludes the Town of Clifton.
- 2/ Excludes the Town of Herndon.
- 3/ Excludes the Town of Vienna.

Acres of Land by Zoning Class  
Planning District  
(JANUARY 1995)

Zoning Class	Mount Vernon		Pohick 1/		Rose Hill		Springfield		Upper Potomac 2/		Vienna 3/		COUNTY TOTAL	
	Total Acres	Vacant Acres	Total Acres	Vacant Acres	Total Acres	Vacant Acres	Total Acres	Vacant Acres	Total Acres	Vacant Acres	Total Acres	Vacant Acres	Total Acres	Vacant Acres
P MF													44	
P MF-R	40						2						76	
P MF-C													2	
PDH-1			478	4					217	54			816	68
PDH-2	8	4	922	108					941	140	15	1	2,929	449
PDH-3			2,033	19			357	12	367	57	128	50	3,692	206
PDH-4			8		793	248	394	183			76	8	1,883	477
PDH-5	69	20	39				97	26	131	4			506	130
PDH-8	4	4			193	62	77	46	24	24			896	175
PDH-12	26		17		13				15	15	76		497	43
PDH-16	14	3			46	46			229	168			451	259
PDH-20	5	5	2						80	27			389	99
PDH-30													7	7
PDH-40	9												24	5
PRC-GC			775	15			686	68	3,046	40			4,507	123
PRC-OS			4						362				366	
PRC-R			534	2			48		1,516	145			2,101	147
PRC-C/I			24				23		714	288			761	288
PRC-CF									65				65	
P PDH													64	26
P PDH-R									5	5			52	5
P PDH-C					248	223			82	82			330	305
PDC					77	60			323	235	83	17	1,181	555
PDC-OS													10	10
PDC-R					16	2							379	33
PDC-C/I													754	322
PDC-CF													11	

(CONTINUED)

- 1/ Excludes the Town of Clifton.
- 2/ Excludes the Town of Herndon.
- 3/ Excludes the Town of Vienna.

Acres of Land by Zoning Class  
Planning District  
(JANUARY 1995)

Zoning Class	Mount Vernon		Pohick 1/		Rose Hill		Springfield		Upper Potomac 2/		Vienna 3/		COUNTY TOTAL	
	Total Acres	Vacant Acres	Total Acres	Vacant Acres	Total Acres	Vacant Acres	Total Acres	Vacant Acres	Total Acres	Vacant Acres	Total Acres	Vacant Acres	Total Acres	Vacant Acres
C-1			4								1		9	
C-2	12		24		17	5	23	14	1		39	4	319	91
C-3	62	20			7	4	6	2	93	4	51	1	818	213
C-4							3				18	2	186	40
C-5	39	5	15	1	14	1	20	2	9	2	15		256	21
C-6	172	9	137	31	35	1	155	13	84	16	44	3	1,218	111
C-7							130	16			102		582	42
C-8	432	45	1		28	5	37	10	165	41	25	4	1,292	300
P COM	27	17					9	2	9		30	14	179	41
P COM-R	136	20	44	7	1		5	1	318	22	20	1	732	86
P COM-I					46	46			5	1			87	48
P COM-N													8	8
I-I					36	10	25	25					104	50
I-1													23	15
I-2							9		25	9			34	9
I-3			12				8	7	241	50	34		1,555	874
I-4					11		362	70	718	383	45		1,737	721
I-5	10		80	10	33	12	634	175	975	508	27	1	3,487	1,377
I-6							349	65	6	6			985	350
P IND							39	31	123	114			840	397
P IND-R			9		186	51	65	7	4		3		885	231
P IND-C									52	52			119	119
P IND-N											4		75	37
TOTAL	11,863	854	45,613	7,033	8,182	1,269	8,887	1,627	40,951	7,909	7,910	773	224,501	36,610

- 1/ Excludes the Town of Clifton.  
2/ Excludes the Town of Herndon.  
3/ Excludes the Town of Vienna.

Acres of Land by Zoning Class within the Towns in Fairfax County  
(JANUARY 1995)

Zoning Class	Town of Clifton	
	Total Acres	Vacant Acres
CL-AGRI	23	15
CL-RES	100	24
CL-COML	4	
CL-IND		
TOTAL	127	39

Zoning Class	Town of Herndon	
	Total Acres	Vacant Acres
H-RPC	109	9
H-PDH	145	
H-SF.5AC	58	19
H-SF15	120	8
H-SF10	979	74
H-RTH5	15	4
H-RGC	31	
H-RTH10	95	4
H-RMF20	116	3
H-MF20	12	4
H-PD-C	60	45
H-PD-SC	25	
H-COMVAR	89	15
H-CENCOM	23	5
H-COMOFC	37	3
H-PD-IP	49	5
H-I-R	111	
H-I-P	156	43
H-I-G	68	30
H-P RES	21	2
H-P MF	7	7
H-P COML	11	11
V-GENCOM	2	1
TOTAL	2,339	292

Zoning Class	Town of Vienna	
	Total Acres	Vacant Acres
V-SF16	567	18
V-SF12.5	562	8
V-SF10	861	7
V-RTH	66	2
V-MFAPT	28	
V-LOCCOM	43	1
V-SPCCOM	31	
V-GENCOM	26	
V-INDPK	76	17
V-LTDIND	27	2
V-TRANS	3	
V-P RES	53	1
V-P COML	34	1
V-P IND	8	
TOTAL	2,385	57



Acres of Land by Land Use Category  
Supervisor District  
(JANUARY 1995)

Land Use	Brad- dock	Dranes- ville 1/	Hunter Mill 2/	Lee	Mason	Mount Vernon	Provi- dence	Spring- field 3/	Sully	Town of Clifton	Town of Herndon	Town of Vienna	TOTAL ACRES
Single Family Detached	6,200	18,938	7,828	5,121	6,428	7,199	6,226	20,991	11,777	69	867	1,541	93,185
Single Family Semi-Detached			18						1				19
Two or More Sgl Fam-Sgl Lot	16	821	348	66	33	1,176	93	658	998		8	12	4,229
Other Sgl Family Structure						6		1				1	8
Sgl Fam Influenced by Busns	6	69	56	76	19	58	25	10	166	2	9	2	498
Duplex	14		2	50		111	2	21			7		207
Other Two Family	2	7		6	10	7	2	18	4		1	1	58
Townhouse-Ownership	239	113	343	406	142	215	316	361	551		78	30	2,794
Townhouse-Condominium	21	23	12	4	39	3	18	91	13		1	1	226
Townhouse-Rental	18	13	3	37	23	20	55	1	9		1		180
Multiplex-Condominium	20	5	68	98	37	51	31	29	82		1	1	423
Rental Combin - Prdom Thse													
Other Townhouse / Multiplex		3	7						4				14
Garden Apts-Rental	119	10	269	383	329	185	385	57	346		67	13	2,163
Garden Apts-Condominium	152		243	139	98	87	251	70	129		30	9	1,208
Medium Rise Apts-Rental		18	20		23		10						71
Medium Rise Apts-Condo	9		4		17								30
HiRise Apts-Rent w/o Comm					36	51	34						121
HiRise Apts-Condo w/o Comm					41	34	67						142
HiRise Apts-Rent w/Comm		4	3		18		17						42
HiRise Apts-Condo w/Comm		6	3		19	27	6						61
Rental Combin - Predom Apts							1						1
Other Apartments				8		4	33	7				1	53
Mobile Homes	26			102		66			82				276
Motels, Hotels, Tourist Homes	2	40	48	34	24	50	54	8	96		19	2	377
Nursing Homes		12			16	45	45						118
Garage, Shed Etc-Sep Parcel	2	148	20	10	12	28	10	73	45			1	349
Priv Open Space-Subdiv	999	1,385	2,485	1,266	398	895	960	2,341	3,005		135	29	13,898

(CONTINUED)

1/ Excludes the Town of Herndon.  
2/ Excludes the Town of Vienna.  
3/ Excludes the Town of Clifton.

Acres of Land by Land Use Category  
Supervisor District  
(JANUARY 1995)

Land Use	Brad- dock	Dranes- ville 1/	Hunter Mill 2/	Lee	Mason	Mount Vernon	Provi- dence	Spring- field 3/	Sully	Town of Clifton	Town of Herndon	Town of Vienna	TOTAL ACRES
Priv Open Space-Not Subdiv	72	50	53	24	83	72	40	60	140		3	12	609
Other Residential	8	33	76	9	28	24	11	34	31			1	255
Other Industrial	4		6	132	69	33	14		177		4		439
Manufacturing	18	1	6	43	120	13	3	20	30		9	4	267
Printing and Publishing	13			2	11								26
Research and Testing		67	36	4	46	7	11		12			1	184
Wholesale-Warehouse Storage	101	8	18	458	138	376	197	9	573		40	14	1,932
Contract Construction		2				9	2		1		2		16
Transportation Related	129	44	2	144	29	225	95	129	2,462	9		2	3,270
Utility Related	70	137	31	47	58	355	33	943	448		19	15	2,156
Communication Related	2	33	6	23	13	12	13	7	5		2		116
Neighborhood Shopping Center		22	7	26	23		27	34	44		16	14	213
Specialty Shopping Center	17	37	3	104	69	39	18	22	64		2	12	387
Community Shopping Center	85	11	64	122	79	18	54	62	204		46	16	761
Regional Shopping Center					56				9				65
Super Regional Center				79			107		118				304
Promotional Center			13	31	69	13	34		12				172
Town Center			31						23				54
Condominium Center		7	4										11
Building Material-Hardware	1	1		9	10	13	24		8		1	3	70
Department and Variety Stores		7	16	55	30		1	10	77			1	197
Apparel / Accessories		1		3	2		4				1	1	12
Furniture	1		4	6	9	6	14						40
Drug Stores		2			1								3
Condominium Retail					1								1
Food Store	1	2	4	13	18	11	6	2	8			3	68
Restaurant	3	21	7	33	33	30	24	3	33		5	8	200
Motor Vehicle Sales	1		51	37	22	24	31		13		3		182

(CONTINUED)

1/ Excludes the Town of Herndon.  
2/ Excludes the Town of Vienna.  
3/ Excludes the Town of Clifton.

Acres of Land by Land Use Category  
Supervisor District  
(JANUARY 1995)

Land Use	Brad- dock	Dranes- ville 1/	Hunter Mill 2/	Lee	Mason	Mount Vernon	Provi- dence	Spring- field 3/	Sully	Town of Clifton	Town of Herndon	Town of Vienna	TOTAL ACRES
Gas Station	6	14	10	19	30	14	22	8	19	1	3	6	152
Other Auto Retail and Repair	1	5	2	35	19	36	19	3	18		6	4	148
Other Retail	2	9	9	7	42	26	47	9	104	1	2	4	262
Other Office	1		4	7	6	1	57				1		77
General Low Rise Office	78	77	502	73	140	63	466	30	605		212	85	2,331
Condominium Office	27	31	20	16	50	15	30	18	11		15	9	242
Cluster Office			2				2					5	9
General Medium/High Rise Office	11	993	344	19	64	9	648		285		33	13	2,419
Finance, Insurance, Real Estate	3	5	1	8	9	1	7	5	2		2	1	44
Personal and Repair Service	1	11		4	8	3	9	4	22	1	2	3	68
Veterinary Hospitals	3	3		1	1	2	1		3		1		15
Cemeteries	90	13	2	54	17	7	176	15	6		24	2	406
Hospital / Health Facilities	93		31	5	3	39	55		13				239
Post Office		1	4		3		29	5	5			4	51
Police Stations				1					128				129
Fire Stations		4	4	5	8	8	7	4	10	1		1	52
Correctional Institutions						2,988	7		22				3,017
Military Institutions		12		1,003		8,183							9,198
Other Public Land Uses	163	583	227	275	103	1,298	74	448	152	1	80	56	3,460
House of Worship	123	219	135	131	253	167	131	240	149	4	43	38	1,633
Civic, Social, Fraternal Uses	6	10	7	11	20	7	48		51		1	12	173
Libraries	3	7	5	4	9	6			21			1	56
Permanent Exhibitions						2,104		5	37			1	2,147
Nursery Schools	4	4	4	7	4	4	15	12	20		3	5	82
Public Schools	449	362	262	369	302	295	366	247	311		51	58	3,072
Private Schools	6	458	36	53	56	15	36	4				4	668

(CONTINUED)

1/ Excludes the Town of Herndon.  
2/ Excludes the Town of Vienna.  
3/ Excludes the Town of Clifton.

Acres of Land by Land Use Category  
Supervisor District  
(JANUARY 1995)

Land Use	Brad- dock	Dranes- ville 1/	Hunter Mill 2/	Lee	Mason	Mount Vernon	Provi- dence	Spring- field 3/	Sully	Town of Clifton	Town of Herndon	Town of Vienna	TOTAL ACRES
Colleges / Universities	633												633
Special Training Schools							4	37					41
Other Institutional Use		9		3		47		28				1	88
Places of Public Assembly		117	17					1					135
Parks	1,380	3,019	2,094	2,317	755	2,580	935	6,450	4,016		30	110	23,686
Indoor Recreation Facility	5	7	7	9	4	11	61	17	105			3	229
Golf Courses		151	330	149		289	58	755	748		159	157	2,796
Swimming Pools									3				3
Boat Slips													
Horticultural Activities		5			8				11				24
Quarries				135		97			200				432
Conservation Areas						1,371							1,371
Water Areas		5											5
Vacant Land	536	5,359	3,014	2,560	672	5,194	1,598	6,165	10,101	32	269	56	35,556
Vacant Land w/Dilap Struct	7	92	145	99	7	152	42	258	614	7	25	1	1,449
<b>TOTAL</b>	<b>12,002</b>	<b>33,686</b>	<b>19,436</b>	<b>16,589</b>	<b>11,372</b>	<b>36,630</b>	<b>14,358</b>	<b>40,840</b>	<b>39,588</b>	<b>128</b>	<b>2,339</b>	<b>2,391</b>	<b>229,359</b>

1/ Excludes the Town of Herndon.  
2/ Excludes the Town of Vienna.  
3/ Excludes the Town of Clifton.

Acres of Land by Land Use Category  
Planning District  
(JANUARY 1995)

Land Use	Annan- dale	Baileys	Bull Run	Fairfax	Jeffer- son	Lincol- nia	Lower Potomac	McLean	Mount Vernon	Pohick 1/	Rose Hill	Spring- field	Upper2/ Potomac	Vienna 3/	TOTAL ACRES
Single Family Detached	5,789	1,906	6,896	5,520	2,529	668	1,678	8,886	5,421	23,083	2,600	2,669	19,649	5,891	93,185
Single Family Semi-Detached				1									18		19
Two or More Sgl Fam-Sgl Lot	22	10	870	79	19	4	1,037	211	110	699	45	20	997	105	4,228
Other Sgl Family Structure									6	1				1	8
Sgl Fam Influenced by Busns	15	5	148	19	20	3	41	6	22	12	43	28	94	42	498
Duplex					1		2		151	42			9	1	206
Other Two Family	4	2	3	1	2	3	2	7	8	19	3		1	2	57
Townhouse-Ownership	127	23	476	95	62	43	60	82	108	573	220	202	511	213	2,795
Townhouse-Condominium	22	22	5	17	9	16		23	7	28		63	13	2	227
Townhouse-Rental	1		9	23	35	23			18	19		33	17	3	181
Multiplex-Condominium	13	6	82	13	2	19	42	21	106	45		6	53	17	425
Rental Combin - Prdom Thse															
Other Townhouse / Multiplex													10	4	14
Garden Apts-Rental	159	146	278	200	192	97	61	104	378	57	94	35	311	49	2,161
Garden Apts-Condominium	124	65	129	112	111	12		37	139	40	81	75	273	9	1,207
Medium Rise Apts-Rental	8	14		10				18					8	11	69
Medium Rise Apts-Condo	9	17											4		30
HiRise Apts-Rent w/o Comm	16	20			21				51					13	121
HiRise Apts-Condo w/o Comm		41			23			45	34						143
HiRise Apts-Rent w/Comm		18			17			4					3		42
HiRise Apts-Condo w/Comm		19						12	27				3		61
Rental Combin - Predom Apts														1	1
Other Apartments				14	19		1		10	7				1	52
Mobile Homes			82	26					168						276
Hotels, Hotels, Tourist Homes	2	15	71	15	22	5	3	63	60	8	3	19	71	22	379
Nursing Homes	11			39		5	40	12	5					6	118
Garage, Shed Etc-Sep Parcel	2	10	28	11	3		19	19	8	73	8	2	159	8	350
Priv Open Space-Subdiv	311	187	1,915	710	141	62	150	535	200	3,495	825	567	4,193	605	13,896

(CONTINUED)

- 1/ Includes the Town of Clifton.
- 2/ Includes the Town of Herndon.
- 3/ Includes the Town of Vienna.

Acres of Land by Land Use Category  
Planning District  
(JANUARY 1995)

Land Use	Annan- dale	Baileys	Bull Run	Fairfax	Jeffer- son	Lincoln- ia	Lower Potomac	McLean	Mount Vernon	Pohick 1/	Rose Hill	Spring- field	Upper2/ Potomac	Vienna 3/	TOTAL ACRES
Priv Open Space-Not Subdiv	72	27	122	36	34	12	19	45	55	72	14	16	55	27	606
Other Residential	8	1	30	8	2	21	15	48	13	38	5	1	41	24	255
Other Industrial	41	16	152	5	3	17	12	2	2		7	144	31	9	441
Manufacturing	126	1	18		3	2	13		1	14		56	29	4	267
Printing and Publishing	24											2			26
Research and Testing	34		2	1	8	12		66				11	49	1	184
Wholesale-Warehouse Storage	99	9	469	18	142	104	210	43	2	29	20	607	153	25	1,930
Contract Construction			1		2		6	2				2	2		15
Transportation Related	79	1	2,462		15	20	152	45	57	196	35	124	2	79	3,267
Utility Related	104	5	395	14	16		228	19	54	971	29	80	224	17	2,156
Communication Related		1	1		8	12	2	21	23	9	7	3	25	2	114
Neighborhood Shopping Center	6	11	24		26			28	14	34		12	44	15	214
Specialty Shopping Center	12	34	64	9	30	3	2	20	68	30	13	61	23	14	383
Community Shopping Center	57	28	109	39	14	29	17	9	98	95	11	21	169	67	763
Regional Shopping Center		56	9												65
Super Regional Center				118				107				79			304
Promotional Center	20	29	12		32	19		2	24		19			13	170
Town Center			23										31		54
Condominium Center													11		11
Building Material-Hardware	10	1		8	15			4	19		3		1	9	70
Department and Variety Stores		21	61	16	1	8			16	10	1	38	19	5	196
Apparel / Accessories	1	1		1	2			1	2			1	1	1	11
Furniture	1	1			10	9		3	10			3	2	5	44
Drug Stores	1							2							3
Condominium Retail		1													1
Food Store	3	12	7	1	7		2	2	11	2	1	8	7	4	67
Restaurant	13	14	29	13	10	4	9	17	34	3	4	19	22	11	202
Motor Vehicle Sales	1	4	11	2	8	14	2	22	39			20	3	56	182

(CONTINUED)

- 1/ Includes the Town of Clifton.
- 2/ Includes the Town of Herndon.
- 3/ Includes the Town of Vienna.

Acres of Land by Land Use Category  
Planning District  
(JANUARY 1995)

Land Use	Annan- dale	Baileys	Bull Run	Fairfax	Jeffer- son	Lincol- nia	Lower Potomac	McLean	Mount Vernon	Pohick 1/	Rose Hill	Spring- field	Upper2/ Potomac	Vienna 3/	TOTAL ACRES
Gas Station	18	9	13	2	13	3	3	13	17	8	6	10	22	14	151
Other Auto Retail and Repair	4	13	18		10		1	7	12	1	3	60	11	7	147
Other Retail	29	11	73	21	14	1	8	3	23	11	1	2	51	14	262
Other Office	2	1			47	4		10	7		1	1	4		77
General Low Rise Office	106	25	326	253	121	24	5	203	63	48	26	46	875	211	2,332
Condominium Office	41	11	11	9	8	6		14	15	22	6	17	57	26	243
Cluster Office					1								2	6	9
General Medium/High Rise Office	27	41	188	156	220			1,244	14			15	390	125	2,420
Finance, Insurance, Real Estate	5	2	2	1	6	3		4	4	7	1	5	4	2	46
Personal and Repair Service	7	2	12	1	2			9	5	4	1	1	21	3	68
Veterinary Hospitals	2		2	1				2	2	3		1	3	1	17
Cemeteries	14		6	91	173	4	2	6	5	16	53		32	3	405
Hospital / Health Facilities	2			55	3				39	91	5		44		239
Post Office	3		5		29			1		5			4	4	51
Police Stations			128						1						129
Fire Stations	3	2	3	3	1		6	5	2	5		5	13	5	53
Correctional Institutions			22	7				2,988							3,017
Military Institutions								8,183			200	803	12		9,198
Other Public Land Uses	95	4	135	27	26	23	876	559	414	566	98	202	248	188	3,461
House of Worship	219	56	76	95	55	14	56	142	114	243	95	70	261	135	1,631
Civic, Social, Fraternal Uses	9	5	2	89	3		5	9	4	6	6	2	10	20	170
Libraries	5	2	21		3			7	6	3	2	2	6	1	58
Permanent Exhibitions			37				556		1,548	5				1	2,147
Nursery Schools	4		14	16					2	17	4	2	17	6	82
Public Schools	281	109	245	158	209	38	14	262	308	382	230	155	431	249	3,071
Private Schools	14	43		16	2	3		463	34	4	34		31	25	669

(CONTINUED)

1/ Includes the Town of Clifton.  
2/ Includes the Town of Herndon.  
3/ Includes the Town of Vienna.

Acres of Land by Land Use Category  
 Planning District  
 (JANUARY 1995)

Land Use	Annan- dale	Baileys	Bull Run	Fairfax	Jeffer- son	Lincol- nia	Lower Potomac	McLean	Mount Vernon	Pohick 1/	Rose Hill	Spring- field	Upper2/ Potomac	Vienna 3/	TOTAL ACRES
Colleges / Universities	76			557											633
Special Training Schools					4					37					41
Other Institutional Use							41		5	28	3		9	1	87
Places of Public Assembly								117		1				17	135
Parks	1,401	132	3,352	938	252	121	1,840	847	483	6,828	1,756	673	4,212	850	23,685
Indoor Recreation Facility	4		8	57				6	14	22	6		109	3	229
Golf Courses			526		58				289	598	149	157	863	157	2,797
Swimming Pools			3												3
Boat Slips															
Horticultural Activities	8		11					4					1		24
Quarries			200				97				135				432
Conservation Areas							1,371								1,371
Water Areas													5		5
Vacant Land	352	163	8,179	1,645	295	241	3,721	1,898	822	6,796	1,238	1,472	7,925	810	35,557
Vacant Land w/Dilap Struct	7	2	500	77	8	1	24	35	31	278	29	154	278	21	1,445
TOTAL	10,085	3,433	29,111	11,469	5,179	1,732	23,622	16,463	11,862	45,739	8,179	8,882	43,292	10,299	229,347

- 1/ Includes the Town of Clifton.  
 2/ Includes the Town of Herndon.  
 3/ Includes the Town of Vienna.



# X. PLANNED LAND USE

## PLANNED LAND USE

The inclusion of planned land use data in the Demographic Reports reflects the demand within the County's residential and nonresidential development community for planning information. The information contained in this section is taken from the Comprehensive Plan for Fairfax County, Virginia, adopted in July 1991, and the plan amendments adopted in the Annual Plan Reviews. The plan amendments which were adopted during 1994 are reflected in the 1995 Demographic Reports.

Planned land uses can generally be divided into three major categories: residential, commercial/industrial, and other nonresidential which includes parks, private recreation, and public and institutional uses. Residential planned uses are expressed as dwelling unit densities. The designation "1 - 2 Du/Ac" means that the planned density on this land is between one to two dwelling units per acre. Ranges of residential planned densities are used to ensure that the Comprehensive Plan remains flexible so that it can be a useful guide to development for a variety of circumstances and development plans.

As of January 1995, the County had 144,960 acres planned for residential uses. This represents approximately 63.2 percent of the County's total developable land. Developable land excludes land that is in roads and water. Land planned for commercial/industrial uses represents 6.2 percent of the County's total developable land, or 14,113 acres. Approximately 9,167 acres are planned for industrial uses while commercial-office planned uses and commercial-retail planned uses total 2,019 acres and 2,927 acres, respectively. Over 31,845 acres, or 13.9 percent, are planned for public parks and open space, and 23,934 acres, or 10.4 percent, are planned for public facilities, governmental areas, and institutional uses. Land primarily planned for private recreation and open space (floodplain) accounts for 11,370 acres, or 5.0 percent. A total of 3,014 acres, or 1.3 percent, are planned for mixed use.

### Underutilized Land Methodology

Vacant and underutilized residential land and vacant commercial/industrial and other nonresidential land totaled 47,330

acres, as of January 1995, representing 20.6 percent of the County's developable land. This undeveloped acreage is the amount of land on which new development may occur. While vacant land, including vacant land in the towns of Clifton, Herndon and Vienna, is easily identified and currently totals 37,006 acres (see the "Existing Land Use" section of the Demographic Reports), measuring underutilized residential land, which totals 10,324 acres, is much more difficult. To estimate underutilized land, a formula was developed that first determines existing utilization of parcel acreage, according to allowable development by the Comprehensive Plan. If current land usage is less than total parcel acreage, and the difference between currently utilized acreage and total acreage is sufficiently large to provide for development of additional housing units, this difference between currently utilized acreage and total acreage is classified as underutilized acreage.

For example, a ten acre parcel that is planned for 1-2 dwelling units per acre but which currently has one dwelling unit on it would yield, via the underutilized land formula, 1 acre of existing utilization and 9 acres of underutilized land.

Based on this formula, as of January 1995, 36,633 acres were vacant or underutilized and planned for residential use. Vacant land planned for commercial uses totaled 932 acres, vacant land planned for industrial uses totaled 3,899 acres, and vacant land planned for other nonresidential uses totaled 5,866 acres.

### Buildout Methodology

Over the last few years there has been a growing demand for dwelling unit estimates and projections resulting from the full implementation of the Comprehensive Plan. These projections are commonly referred to as "buildout" since these projections are expected to reflect the housing composition of the County if it is completely developed in accordance with the currently adopted Comprehensive Plan.

While the buildout methodology is detailed, its concepts and general procedures are straightforward. Long-range projections of dwelling units are generated by the analysis of land uses and densities shown in the

County's Comprehensive Land Use Plan and expressed as dwelling units per acre. However, the Comprehensive Plan and existing development are often not in agreement in terms of land uses or planned densities. Also, since the Comprehensive Plan is a document of general development directions and land use suggestions, it cannot be expected to describe fully the wide range of current development options. Therefore, buildout is calculated by adding the number of units that could be built on currently vacant or underutilized residentially planned land to the existing number of dwelling units. The number of these additional units is determined by applying the planned land use densities and their assigned housing types to the undeveloped land.

Buildout can be calculated using the low, midpoint, or high end of the planned density ranges. In the reports presented here, the midpoints of the planned density ranges are used for most areas of the County. However, in Fairfax Center (the Route 50/Interstate 66 area), the Comprehensive Plan prefers residential development to occur at the high end of the planned densities. Consequently, buildout for the Fairfax Center area is assumed to be at the high end of the residential planned densities and buildout for the rest of the County is calculated at the midpoint of the planned densities.

The housing types are defined as SF = Single-family, TH = Townhouse, and MF = Multifamily. Single-family units are expected to be built on land planned at densities less than the midpoint of the range of 4 - 5 du/ac. Townhouses are defined as units to be built on land planned between the midpoint of the density range of 4 - 5 du/ac and the midpoint of the density range of 8 - 12 du/ac. Multifamily units are expected to be built on land planned for densities greater than the midpoint of the 8 - 12 du/ac range.

Using the methodology described above, the County will have 392,383 housing units at planned buildout. Since there are currently 328,151 units in the County, 64,232 additional units may be seen at buildout. The additional units represent a 19.6 percent increase in the County's total housing stock. The majority (59.3 percent) of the additionally planned units is expected to be single-family homes, while townhouses and multifamily units are expected to comprise 16.7 percent and 24.0 percent, respectively, of the additionally planned units.

Among the supervisor districts, Lee has the largest number of additionally planned units, with 12,701. There are 12,026 additional

units planned for the Sully District which has the second largest number of additionally planned units. The Braddock District has the smallest number of additionally planned units, with 1,391.

Among the planning districts, Upper Potomac is planned to accommodate 12,635 additional units, while Bull Run is planned to accommodate 9,480 additional units. These two planning districts, together with the planned units for Springfield (7,935 units) account for 46.8 percent of all planned units in the County.

Acres of Land by Planned Land Use  
Supervisor District  
(January 1995)

Planned Land Use	Braddock	Dranesville 1/	Hunter Mill 2/	Lee	Mount Vernon	Providence	Springfield 3/	Sully	Town of Clifton	Mason	Town of Herndon	Town of Vienna	Total Acres	
Residential	.1-.2 HU/Ac	354	3,015	158	1,295	44	20,593	8,839					34,298	
	.2-.5 HU/Ac	40	9,856	1,580	2,771	715	1,390	1,577	1				17,930	
	.5-1 HU/Ac	22	2,471	3,016	364	790	1,555	2,428	125	332			11,103	
	1-2 HU/Ac	1,425	5,445	1,838	931	667	1,409	1,358	3,792	2,350	11		19,226	
	2-3 HU/Ac	4,606	3,640	1,660	4,169	5,605	2,839	3,490	3,806	3,578	78	895	34,366	
	3-4 HU/Ac	234	878	13	2,760	580	1,580	96	1,129	879	1,003	762	9,914	
	4-5 HU/Ac	71	126	50	245	206	160	265	177	79	91	1	1,471	
	5-8 HU/Ac	239	65	108	477	566	510	146	1,065	262	46	13	3,497	
	8-12 HU/Ac	195	75	98	274	305	345	93	237	90	122	16	1,850	
	12-16 HU/Ac		52	114	20	22	107		89	147			551	
	16-20 HU/Ac	186	49	57	513	405	811	40	289	405	131	10	2,896	
	20-30 HU/Ac				5	9	99						13	126
	30-40 HU/Ac		14		26									40
	Mobile Home				17				82					99
Res Planned Com	601	96	5,409	165			1,283	36		3			7,593	
Subtotal	7,973	25,782	14,101	9,602	12,795	9,409	30,309	23,546	126	8,125	1,482	1,710	144,960	
Commercial/ Industrial	Industrial	274	62	1,593	1,028	896	623	31	3,708	562	303	87	9,167	
	Comm-Retail	110	178	156	483	208	574	114	348	523	125	108	2,927	
	Comm-Office	45	41	81	274	177	569	8	543	213	63	5	2,019	
	Subtotal	429	281	1,830	1,785	1,281	1,766	153	4,599	1,298	491	200	14,113	
Other Non- Residential	Mixed Use		62	291	1,054	316	247		971	73			3,014	
	Public Facility	1,546	1,949	568	1,083	12,255	902	921	3,733	10	763	99	23,934	
	Public Parks	1,419	4,151	2,149	2,654	7,323	1,305	7,263	4,588	733	118	142	31,845	
	Private Rec	473	1,210	404	268	2,441	417	1,803	1,444	274	79	205	9,018	
	Floodplain	151	245	92	110	208	283	369	716	86	73	19	2,352	
Subtotal	3,589	7,617	3,504	5,169	22,543	3,154	10,356	11,452	10	1,929	369	471	70,163	
<b>Total</b>	<b>11,991</b>	<b>33,680</b>	<b>19,435</b>	<b>16,556</b>	<b>36,619</b>	<b>14,329</b>	<b>40,818</b>	<b>39,597</b>	<b>136</b>	<b>11,352</b>	<b>2,342</b>	<b>2,381</b>	<b>229,236</b>	

- 1/ Excludes land in the Town of Herndon.  
2/ Excludes land in the Town of Vienna.  
3/ Excludes land in the Town of Clifton.

Acres of Land by Planned Land Use  
Planning District  
(January 1995)

Planned Land Use	Bull Run	Fairfax	Jefferson	Lower Potomac	Pohick 1/	Springfield	Upper2/ Potomac	McLean	Mount Vernon	Vienna 3/	Annan-dale	Baileys	Lincoln-ia	Rose Hill	Total Acres	
Residential	.1-.2 HU/Ac	8,773	409	2	856	21,036	3,222								34,298	
	.2-.5 HU/Ac	11	1,466		2,600	1,601	10,520	1,419	1	312					17,930	
	.5-1 HU/Ac	117	1,450	44	55	1,992	5,998	484		659	304				11,103	
	1-2 HU/Ac	3,165	768	500	209	2,222	963	1,706	5,336	1,769	1,470	205	627	286	19,226	
	2-3 HU/Ac	2,649	1,819	882	106	4,793	1,729	3,028	2,707	5,358	2,707	4,134	1,854	120	2,480	34,366
	3-4 HU/Ac	722	298	1,497		151	976	1,373	875	714	1,236	301	20	105	1,646	9,914
	4-5 HU/Ac	154	51	26	87	300	176	161	126	134	122	27	31	21	55	1,471
	5-8 HU/Ac	938	382	108	306	343	69	164	65	393	162	71	27	194	275	3,497
	8-12 HU/Ac	237	51	105	155	172	133	249	46	300	219	155	23	4	1	1,850
	12-16 HU/Ac	55	34	100	22			91	45	15	37	78	34	35	5	551
	16-20 HU/Ac	259	397	320	104	40	59	175	146	728	97	184	278	82	27	2,896
	20-30 HU/Ac						5		99	9	13					126
	30-40 HU/Ac						26		14							40
	Mobile Home	82								17						99
	Res Planned Com	1		3		1,292	757	5,540								7,593
Subtotal	17,163	7,125	3,587	4,500	33,942	4,893	32,227	11,362	7,669	7,333	6,724	2,472	1,188	4,775	144,960	
Commercial/ Industrial	Industrial	2,657	25	97	550	93	1,363	2,880	514	3	205	557	12	175	36	9,167
	Comm-Retail	173	213	156	91	152	271	263	385	268	367	182	246	96	64	2,927
	Comm-Office	387	299	244	85	16	76	172	130	134	93	122	77	28	156	2,019
	Subtotal	3,217	537	497	726	261	1,710	3,315	1,029	405	665	861	335	299	256	14,113
Other Non- Residential	Mixed Use	640	334	178	288		819	360	8	136	51		73		127	3,014
	Public Facility	3,481	1,129	506	11,725	1,241	458	811	1,731	553	539	812	215	77	656	23,934
	Public Parks	3,136	1,693	305	5,876	7,657	626	4,649	1,912	1,262	979	1,317	156	110	2,167	31,845
	Private Rec	909	376	49	389	2,250	220	1,656	263	1,772	588	197	140	29	180	9,018
	Floodplain	573	271	30	123	372	152	289	150	37	124	170	27	27	7	2,352
Subtotal	8,739	3,803	1,068	18,401	11,520	2,275	7,765	4,064	3,760	2,281	2,496	611	243	3,137	70,163	
<b>Total</b>	<b>29,119</b>	<b>11,465</b>	<b>5,152</b>	<b>23,627</b>	<b>45,723</b>	<b>8,878</b>	<b>43,307</b>	<b>16,455</b>	<b>11,834</b>	<b>10,279</b>	<b>10,081</b>	<b>3,418</b>	<b>1,730</b>	<b>8,168</b>	<b>229,236</b>	

- 1/ Includes land in the Town of Clifton.  
2/ Includes land in the Town of Herndon.  
3/ Includes land in the Town of Vienna.

Acres of Vacant and Underutilized Residential Land  
 Acres of Vacant Nonresidential Land  
 by Planned Land Use  
 Supervisor District  
 (January 1995)

Planned Land Use		Braddock	Dranesville 1/	Hunter Mill 2/	Lee	Mount Vernon	Providence	Springfield 3/	Sully	Town of Clifton	Mason	Town of Herndon	Town of Vienna	TOTAL ACRES
Residential	.1-.2 HU/Ac	251	1,184	8		1,006	12	6,625	5,682					14,768
	.2-.5 HU/Ac	6	2,557	438		1,777	163	356	295					5,592
	.5-1 HU/Ac	5	682	1,061		139	327	601	515	67	23			3,420
	1-2 HU/Ac	150	1,572	281	288	399	186	157	1,387		271	2		4,693
	2-3 HU/Ac	244	386	443	653	732	485	309	402		374	15	43	4,086
	3-4 HU/Ac	28	53	1	707	87	246	7	333		51	205	24	1,742
	4-5 HU/Ac	3	31		73	82	59	51	1		20	6		326
	5-8 HU/Ac	15	13	41	120	124	124	16	259		23			735
	8-12 HU/Ac	6	2	98	59	83	31	1	18		11	22		331
	12-16 HU/Ac		17	77	4		7		24		4			133
	16-20 HU/Ac	2	26	12	35	77	61		49		12	11		285
	20-30 HU/Ac				5		8							13
	30-40 HU/Ac				18									18
	Mobile Home				2									2
	Res Planned Com		30	375	3			81						489
SUBTOTAL		710	6,553	2,835	1,967	4,506	1,709	8,204	8,965	67	789	261	67	36,633
Commercial/ Industrial	Industrial	24	16	759	363	324	92	6	2,160		41	97	17	3,899
	Comm-Retail	4	7	4	25	72	115		27		16	22		292
	Comm-Office	3	8	38	113	98	110		221		22	27		640
	SUBTOTAL		31	31	801	501	494	317	6	2,408		79	146	17
Other Non-Residential	Mixed Use		9	223	119	272	46		637		9			1,315
	Public Facility	5	65	34	75	161	5	6	92		9	1	2	455
	Public Parks	13	256	124	304	621	70	101	596		52	5		2,142
	Private Rec		295	28	37	404	43	82	157		5		2	1,053
	Floodplain	8	99	26	73	136	74	198	245		42			901
SUBTOTAL		26	724	435	608	1,594	238	387	1,727		117	6	4	5,866
TOTAL		767	7,308	4,071	3,076	6,594	2,264	8,597	13,100	67	985	413	88	47,330

1/ Excludes land in the Town of Herndon.  
 2/ Excludes land in the Town of Vienna.  
 3/ Excludes land in the Town of Clifton.

Acres of Vacant and Underutilized Residential Land  
 Acres of Vacant Nonresidential Land  
 by Planned Land Use  
 Planning District  
 (January 1995)

Planned Land Use	Bull Run	Fairfax	Jefferson	Lower Potomac	Pohick 1/	Springfield	Upper2/ Potomac	McLean	Mount Vernon	Vienna 3/	Annan-dale	Baileys	Lincol-nia	Rose Hill	Total Acres	
Residential	.1-.2 HU/Ac	5,670	269		675	6,960	1,194								14,768	
	.2-.5 HU/Ac	5	239		1,704	434	2,803	398	1	8					5,592	
	.5-1 HU/Ac	15	371	3	20	787	1,926	82		194	22				3,420	
	1-2 HU/Ac	1,249	148	37	139	232	454	278	1,555	266	167	19	104	45	4,693	
	2-3 HU/Ac	253	201	118	9	536	169	595	281	643	375	184	145	117	460	4,086
	3-4 HU/Ac	257	71	68		9	261	260	50	85	196	31	7		447	1,742
	4-5 HU/Ac	1	4	2	42	54	28	6	31	81	53	9	7	4	4	326
	5-8 HU/Ac	229	65	76	68	30	8	30	13	80	25	1	4	18	88	735
	8-12 HU/Ac	18	4	4	79	2	18	120	2	45	25	6	7	1		331
	12-16 HU/Ac		24	7				91	3	4				4		133
	16-20 HU/Ac	35	34	9	73		22	47	7	17	28	2	11			285
	20-30 HU/Ac						5		8							13
	30-40 HU/Ac						18									18
	Mobile Home									2						2
Res Planned Com					16	68	405								489	
Subtotal	7,732	1,430	324	2,809	9,060	1,051	7,755	2,430	958	1,170	422	200	248	1,044	36,633	
Commercial/ Industrial	Industrial	1,608	7		271	7	406	1,405	103	20	46	1	9	16	3,899	
	Comm-Retail	25	3	14	46	4	22	34	82	25	22	4	7	1	292	
	Comm-Office	143	123	33	80		22	80	21	26	9	14	5	1	83	
	Subtotal	1,776	133	47	397	11	450	1,519	206	51	51	64	13	11	102	4,831
Other Non- Residential	Mixed Use	365	265	31	272			239	8	7		9		119	1,315	
	Public Facility	62	19	3	130	5	36	66	45	35	4	10	1	2	37	
	Public Parks	465	135	1	438	110	195	263	119	72	69	41	4	10	220	
	Private Rec	103	75		365	82	11	296	12	56	39	4	1		9	
	Floodplain	200	81	6	96	204	87	59	70	13	28	12	12	26	7	
Subtotal	1,195	575	41	1,301	401	329	923	254	176	147	67	27	38	392	5,866	
<b>Total</b>	<b>10,703</b>	<b>2,138</b>	<b>412</b>	<b>4,507</b>	<b>9,472</b>	<b>1,830</b>	<b>10,197</b>	<b>2,890</b>	<b>1,185</b>	<b>1,368</b>	<b>553</b>	<b>240</b>	<b>297</b>	<b>1,538</b>	<b>47,330</b>	

- 1/ Includes land in the Town of Clifton.  
 2/ Includes land in the Town of Herndon.  
 3/ Includes land in the Town of Vienna.

Housing Units at Planned Buildout  
Supervisor District  
(January 1995)

Supervisor District	Existing Units				Additionally Planned Units				Buildout Units			
	SF	TH	MF	TOTAL	SF	TH	MF	TOTAL	SF	TH	MF	TOTAL
Braddock	19,805	6,399	4,610	30,814	1,180	153	58	1,391	20,985	6,552	4,668	32,205
Dranesville 1/	26,674	4,426	3,095	34,195	6,946	278	1,056	8,280	33,620	4,704	4,151	42,475
Hunter Mill 2/	18,568	9,693	8,867	37,128	3,194	1,878	3,233	8,305	21,762	11,571	12,100	45,433
Lee	16,819	11,550	9,788	38,157	5,601	2,574	4,526	12,701	22,420	14,124	14,314	50,858
Mason	16,236	4,684	16,068	36,988	2,003	243	332	2,578	18,239	4,927	16,400	39,566
Mount Vernon	15,934	7,501	9,432	32,867	5,215	1,340	1,687	8,242	21,149	8,841	11,119	41,109
Providence	13,942	9,237	17,447	40,626	3,436	1,321	2,198	6,955	17,378	10,558	19,645	47,581
Springfield 3/	21,308	9,706	1,822	32,836	3,521	214	19	3,754	24,829	9,920	1,841	36,590
Sully	23,073	14,160	7,307	44,540	6,963	2,751	2,312	12,026	30,036	16,911	9,619	56,566
<b>TOTAL</b>	<b>172,359</b>	<b>77,356</b>	<b>78,436</b>	<b>328,151</b>	<b>38,059</b>	<b>10,752</b>	<b>15,421</b>	<b>64,232</b>	<b>210,418</b>	<b>88,108</b>	<b>93,857</b>	<b>392,383</b>

Housing Units at Planned Buildout  
Towns  
(January 1995)

Town	Existing Units				Additionally Planned Units				Buildout Units			
	SF	TH	MF	TOTAL	SF	TH	MF	TOTAL	SF	TH	MF	TOTAL
Town of Clifton	68			68	71			71	139			139
Town of Herndon	2,698	1,791	1,871	6,360	802	112	317	1,231	3,500	1,903	2,188	7,591
Town of Vienna	4,542	444	524	5,510	227	1		228	4,769	445	524	5,738
<b>TOTAL</b>	<b>7,308</b>	<b>2,235</b>	<b>2,395</b>	<b>11,938</b>	<b>1,100</b>	<b>113</b>	<b>317</b>	<b>1,530</b>	<b>8,408</b>	<b>2,348</b>	<b>2,712</b>	<b>13,468</b>

- 1/ Includes the Town of Herndon.  
2/ Includes the Town of Vienna.  
3/ Includes the Town of Clifton.



Housing Units at Planned Buildout  
Planning District  
(JANUARY 1995)

Planning District	Existing Units				Additionally Planned Units				Buildout Units			
	SF	TH	MF	TOTAL	SF	TH	MF	TOTAL	SF	TH	MF	TOTAL
Annandale	15,833	3,374	5,950	25,157	1,009	58	64	1,131	16,842	3,432	6,014	26,288
Baileys	5,074	880	10,977	16,931	550	74	238	862	5,624	954	11,215	17,793
Bull Run	15,049	12,266	5,802	33,117	5,376	2,499	1,605	9,480	20,425	14,765	7,407	42,597
Fairfax	8,594	3,135	7,125	18,854	1,650	600	1,078	3,328	10,244	3,735	8,203	22,182
Jefferson	8,463	2,370	7,529	18,362	781	526	975	2,282	9,244	2,896	8,504	20,644
Lincolnia	1,483	1,821	2,267	5,571	639	129	62	830	2,122	1,950	2,329	6,401
Lower Potomac	1,399	2,160	1,438	4,997	1,904	878	1,576	4,358	3,303	3,038	3,014	9,355
McLean	16,308	1,965	5,795	24,068	3,967	215	356	4,538	20,275	2,180	6,151	28,606
Mount Vernon	16,319	5,851	13,839	36,009	2,580	928	602	4,110	18,899	6,779	14,441	40,119
Pohick 1/	27,452	14,836	1,448	43,736	4,559	329	7	4,895	32,011	15,165	1,455	48,631
Rose Hill	7,884	5,167	3,216	16,267	3,212	714	6	3,932	11,096	5,881	3,222	20,199
Springfield	8,144	5,546	1,549	15,239	2,492	1,399	4,044	7,935	10,636	6,945	5,593	23,174
Upper Potomac 2/	27,288	13,198	9,423	49,909	6,601	1,867	4,167	12,635	33,889	15,065	13,590	62,544
Vienna 3/	13,069	4,787	2,078	19,934	2,739	536	641	3,916	15,808	5,323	2,719	23,850
TOTAL	172,359	77,356	78,436	328,151	38,059	10,752	15,421	64,232	210,418	88,108	93,857	392,383

- 1/ Includes the Town of Clifton.  
2/ Includes the Town of Herndon.  
3/ Includes the Town of Vienna.

Housing Units at Planned Buildout  
Sewershed  
(JANUARY 1995)

Sewershed Code	Existing Units				Additionally Planned Units				Buildout Units			
	SF	TH	MF	TOTAL	SF	TH	MF	TOTAL	SF	TH	MF	TOTAL
A1	5,816	716	283	6,815	1,070	1,134	1,872	4,076	6,886	1,850	2,155	10,891
A2	14	232		246		235	701	936	14	467	701	1,182
A3	205	565		770	46		623	669	251	565	623	1,439
B1	887	370	414	1,671	96	2	2	100	983	372	416	1,771
B2	3,831	1,359	534	5,724	709	156	436	1,301	4,540	1,515	970	7,025
B3	617			617	181			181	798			798
B5 1/	2,698	1,792	1,707	6,197	802	112	317	1,231	3,500	1,904	2,024	7,428
C1	896			896	350			350	1,246			1,246
C2	1,053	1		1,054	468			468	1,521	1		1,522
D1	2,470	2		2,472	965			965	3,435	2		3,437
D2	1,876	2,875	3,698	8,449	745	112	105	962	2,621	2,987	3,803	9,411
D3 2/	16,610	5,069	4,683	26,362	2,833	268	113	3,214	19,443	5,337	4,796	29,576
E1	1,965	566	3,547	6,078	674	49	240	963	2,639	615	3,787	7,041
E2	482			482	610			610	1,092			1,092
F	1,815	324	500	2,639	349	49	39	437	2,164	373	539	3,076
G1	7,651	1,946	2,725	12,322	1,091	117	142	1,350	8,742	2,063	2,867	13,672
G2	944		240	1,184	235			235	1,179		240	1,419
G3	664	35		699	279			279	943	35		978
G4	339			339	47			47	386			386
H1	1,180	355	4,206	5,741	200	32	77	309	1,380	387	4,283	6,050
H2			3,409	3,409			88	88			3,497	3,497
H3	184			184	36		12	48	220		12	232
I1	13,506	2,303	8,648	24,457	1,309	566	899	2,774	14,815	2,869	9,547	27,231
I2	1,168	36		1,204	160	4	72	236	1,328	40	72	1,440
I3	9,517	5,326	3,574	18,417	1,532	618	183	2,333	11,049	5,944	3,757	20,750
I4	45			45	23			23	68			68
I5	237	35		272	69	6		75	306	41		347
J1	3,700	1,466	2,916	8,082	671	36	54	761	4,371	1,502	2,970	8,843

(CONTINUED)

- 1/ Town of Herndon.
- 2/ Comprises part of the Town of Vienna.
- 3/ Town of Clifton.

Housing Units at Planned Buildout  
Sewershed  
(JANUARY 1995)

Sewershed Code	Existing Units				Additionally Planned Units				Buildout Units			
	SF	TH	MF	TOTAL	SF	TH	MF	TOTAL	SF	TH	MF	TOTAL
J2	925	112	2,173	3,210	105	23	15	143	1,030	135	2,188	3,353
J3	1,118	351	496	1,965	223	1	9	233	1,341	352	505	2,198
J4	727	25	1,454	2,206	84	1	7	92	811	26	1,461	2,298
K	9,317	2,591	4,731	16,639	1,321	594	234	2,149	10,638	3,185	4,965	18,788
L	6,408	5,144	5,241	16,793	2,782	573	288	3,643	9,190	5,717	5,529	20,436
M0	1,060	123	921	2,104	147	2	3	152	1,207	125	924	2,256
M1	699	1,595	1,852	4,146	266	87	360	713	965	1,682	2,212	4,859
M2 2/	10,964	5,177	8,056	24,197	1,772	347	690	2,809	12,736	5,524	8,746	27,006
M3	6,133	229		6,362	145		15	160	6,278	229	15	6,522
M4	4,829	1,883	1,163	7,875	390	29	9	428	5,219	1,912	1,172	8,303
M5	1,351	1,354		2,705	294	1,001	3,025	4,320	1,645	2,355	3,025	7,025
M6	1,424	2,514		3,938	1,784	411	937	3,132	3,208	2,925	937	7,070
M7	30	2	195	227				0	30	2	195	227
M8	18			18	150	1		151	168	1		169
M9	319	696	1,476	2,491	185	459	427	1,071	504	1,155	1,903	3,562
N1	18,764	14,968	2,691	36,423	1,737	975	1,538	4,250	20,501	15,943	4,229	40,673
N2	3,641	1,796		5,437	779	79		858	4,420	1,875		6,295
O1	435	2		437	1,290			1,290	1,725	2		1,727
P	109	2		111	288			288	397	2		399
P1	71			71	103	65		168	174	65		239
P2	176			176	9			9	185			185
P3	803			803	238			238	1,041			1,041
Q1	2,163			2,163	1,034	4	4	1,042	3,197	4	4	3,205
R1	2,574	4		2,578	706			706	3,280	4		3,284
R2	226			226	29			29	255			255
R3 3/	69			69	71			71	140			140
R4	231			231	146			146	377			377
S1	3,199	3,583	1,248	8,030	2,269	345		2,614	5,468	3,928	1,248	10,644

(CONTINUED)

- 1/ Town of Herndon.
- 2/ Comprises part of the Town of Vienna.
- 3/ Town of Clifton.

Housing Units at Planned Buildout  
Sewershed  
(JANUARY 1995)

Sewershed Code	Existing Units				Additionally Planned Units				Buildout Units			
	SF	TH	MF	TOTAL	SF	TH	MF	TOTAL	SF	TH	MF	TOTAL
S2	212			212	183			183	395			395
T1	1,534			1,534	133			133	1,667			1,667
T2	3,609	2,285	229	6,123	1,110	26	17	1,153	4,719	2,311	246	7,276
T3	3,454	2,239		5,693	389			389	3,843	2,239		6,082
T4	2,386	1,376	2,868	6,630	320	769	655	1,744	2,706	2,145	3,523	8,374
T5	2,293	3,313	2,276	7,882	953	889	1,213	3,055	3,246	4,202	3,489	10,937
T6	54			54	500			500	554			554
T7	664	619	282	1,565	574	575		1,149	1,238	1,194	282	2,714
TOTAL	172,359	77,356	78,436	328,151	38,059	10,752	15,421	64,232	210,418	88,108	93,857	392,383

- 1/ Town of Herndon.
- 2/ Comprises part of the Town of Vienna.
- 3/ Town of Clifton.

Housing Units at Planned Buildout  
Census and Subcensus Tract  
(January 1995)

Census Tract	Subcensus Tract	Existing Units				Additionally Planned Units				Buildout Units			
		SF	TH	MF	TOTAL	SF	TH	MF	TOTAL	SF	TH	MF	TOTAL
151	151.01	403	74		477	65	8		73	468	82		550
	151.02	410	2	103	515	64	11	9	84	474	13	112	599
	151.03	307			307	50			50	357			357
	Census Tract Total	1,120	76	103	1,299	179	19	9	207	1,299	95	112	1,506
152	152.01	200	133		333	46	1		47	246	134		380
	152.02	18	20	1,454	1,492	5		7	12	23	20	1,461	1,504
	152.03	117			117	20			20	137			137
	152.04					1			1	1			1
	Census Tract Total	335	153	1,454	1,942	72	1	7	80	407	154	1,461	2,022
153	153.01	224	58		282	103	1		104	327	59		386
	153.02	269	204	147	620	16			16	285	204	147	636
	153.03	180	291		471	5			5	185	291		476
	153.04	100			100	1			1	101			101
	Census Tract Total	773	553	147	1,473	125	1		126	898	554	147	1,599
154	154.01	717	156	1,555	2,428	99	30		129	816	186	1,555	2,557
	154.02	407			407	41			41	448			448
	154.03	123	227	55	405	15	41		56	138	268	55	461
	Census Tract Total	1,247	383	1,610	3,240	155	71		226	1,402	454	1,610	3,466
155	155.01	438	400	339	1,177	103	199		302	541	599	339	1,479
	155.02	688			688	16			16	704			704
	155.03	265			265	38			38	303			303
	155.04	90			90	6			6	96			96
	Census Tract Total	1,481	400	339	2,220	163	199		362	1,644	599	339	2,582
156	156.01	548			548	34			34	582			582
	156.02	79			79	2			2	81			81
	156.03	291	2		293	73			73	364	2		366
	156.04	116			116	266			266	382			382
	Census Tract Total	1,034	2		1,036	375			375	1,409	2		1,411
157	157.01	432			432	17			17	449			449
	157.02	747			747	34			34	781			781

(CONTINUED)

Housing Units at Planned Buildout  
Census and Subcensus Tract  
(January 1995)

Census Tract	Subcensus Tract	Existing Units				Additionally Planned Units				Buildout Units			
		SF	TH	MF	TOTAL	SF	TH	MF	TOTAL	SF	TH	MF	TOTAL
157	157.03	191	2		193	5			5	196	2		198
	Census Tract Total	1,370	2		1,372	56			56	1,426	2		1,428
158	158.01	668			668	100			100	768			768
	158.02	530			530	58			58	588			588
	158.03	462			462	95			95	557			557
	Census Tract Total	1,660			1,660	253			253	1,913			1,913
159	159.01	851			851	89			89	940			940
	159.02	185	5		190	82			82	267	5		272
	159.03												
	159.04	125			125	27			27	152			152
	Census Tract Total	1,161	5		1,166	198			198	1,359	5		1,364
160	160.01	111	2	169	282	129	6	51	186	240	8	220	468
	160.02	603	151	242	996	27	106	2	135	630	257	244	1,131
	160.03	296			296	34			34	330			330
	Census Tract Total	1,010	153	411	1,574	190	112	53	355	1,200	265	464	1,929
161	161.01	141		45	186	121			121	262		45	307
	161.02	97			97	11			11	108			108
	161.03	624			624	101			101	725			725
	161.04	461			461	172			172	633			633
	Census Tract Total	1,323		45	1,368	405			405	1,728		45	1,773
162	162.01												
	162.02												
	Census Tract Total												
163	163.01	249			249	860			860	1,109			1,109
	163.02	465	4		469	730			730	1,195	4		1,199
	Census Tract Total	714	4		718	1,590			1,590	2,304	4		2,308
201	201.01	436			436	1			1	437			437
	201.02	467	140		607	108	6	6	120	575	146	6	727
	Census Tract Total	903	140		1,043	109	6	6	121	1,012	146	6	1,164
202	202.01	503	719		1,222	190	43	1	234	693	762	1	1,456

(CONTINUED)

Housing Units at Planned Buildout  
Census and Subcensus Tract  
(January 1995)

Census Tract	Subcensus Tract	Existing Units				Additionally Planned Units				Buildout Units			
		SF	TH	MF	TOTAL	SF	TH	MF	TOTAL	SF	TH	MF	TOTAL
202	202.02	539	309		848	76	369		445	615	678		1,293
	Census Tract Total	1,042	1,028		2,070	266	412	1	679	1,308	1,440	1	2,749
203	203.01	638			638	45			45	683			683
	203.02	386	286		672	140			140	526	286		812
	203.03	242			242	12			12	254			254
	203.04	210	80		290	160			160	370	80		450
	Census Tract Total	1,476	366		1,842	357			357	1,833	366		2,199
204	204.01	25	273	1,288	1,586	20	9	4	33	45	282	1,292	1,619
	Census Tract Total	25	273	1,288	1,586	20	9	4	33	45	282	1,292	1,619
205	205.01	82	443	2,597	3,122	1	14	24	39	83	457	2,621	3,161
	205.02	171	8		179	7		14	21	178	8	14	200
	Census Tract Total	253	451	2,597	3,301	8	14	38	60	261	465	2,635	3,361
206	206.01	60	120		180	4			4	64	120		184
	206.02		360	67	427		1		1		361	67	428
	206.03	350	145	556	1,051	77	12	22	111	427	157	578	1,162
	Census Tract Total	410	625	623	1,658	81	13	22	116	491	638	645	1,774
207	207.01	625			625	36			36	661			661
	207.02	129			129	75			75	204			204
	207.03	548			548	53			53	601			601
	Census Tract Total	1,302			1,302	164			164	1,466			1,466
208	208.01	335			335	48			48	383			383
	208.02	265			265	31			31	296			296
	208.03	481	73		554	83			83	564	73		637
	Census Tract Total	1,081	73		1,154	162			162	1,243	73		1,316
210	210.01	280			280	155	155	823	1,133	435	155	823	1,413
	210.02	61	583		644	8	105	73	186	69	688	73	830
	210.03	178	64		242	139	25		164	317	89		406
	210.04	287			287	2			2	289			289
	Census Tract Total	806	647		1,453	304	285	896	1,485	1,110	932	896	2,938
211	211.01	496	1,608		2,104	1,290	45		1,335	1,786	1,653		3,439

(CONTINUED)

Housing Units at Planned Buildout  
Census and Subcensus Tract  
(January 1995)

Census Tract	Subcensus Tract	Existing Units				Additionally Planned Units				Buildout Units			
		SF	TH	MF	TOTAL	SF	TH	MF	TOTAL	SF	TH	MF	TOTAL
211	211.02	333	622	538	1,493	541	148		689	874	770	538	2,182
	211.03	10	182		192	123	1		124	133	183		316
	Census Tract Total	839	2,412	538	3,789	1,954	194		2,148	2,793	2,606	538	5,937
212	212.01	691			691	2			2	693			693
	Census Tract Total	691			691	2			2	693			693
213	213.01	913	438		1,351	14	1		15	927	439		1,366
	213.02	42	62		104	9			9	51	62		113
	Census Tract Total	955	500		1,455	23	1		24	978	501		1,479
214	214.01	199	2	727	928	37	4		41	236	6	727	969
	214.02	285	31	1,186	1,502	46	71	49	166	331	102	1,235	1,668
	Census Tract Total	484	33	1,913	2,430	83	75	49	207	567	108	1,962	2,637
215	215.01	1,181		801	1,982	141	246	113	500	1,322	246	914	2,482
	Census Tract Total	1,181		801	1,982	141	246	113	500	1,322	246	914	2,482
216	216.01	95	1,003	323	1,421	1			1	96	1,003	323	1,422
	216.02	85	112	340	537	2	42	62	106	87	154	402	643
	Census Tract Total	180	1,115	663	1,958	3	42	62	107	183	1,157	725	2,065
217	217.01	1,082	941	656	2,679	13	80	49	142	1,095	1,021	705	2,821
	Census Tract Total	1,082	941	656	2,679	13	80	49	142	1,095	1,021	705	2,821
218	218.01	190	686	1,189	2,065	60	46	196	302	250	732	1,385	2,367
	Census Tract Total	190	686	1,189	2,065	60	46	196	302	250	732	1,385	2,367
219	219.01												
	Census Tract Total												
220	220.01	1			1					1			1
	220.02												
	220.03	268	224		492	14	42		56	282	266		548
	220.04	10			10		42	41	83	10	42	41	93
	220.05	30	2	195	227					30	2	195	227
	Census Tract Total	309	226	195	730	14	84	41	139	323	310	236	869
221	221.01	205	636	990	1,831	42	130		172	247	766	990	2,003
	221.02	1			1	16			16	17			17

(CONTINUED)



Housing Units at Planned Buildout  
Census and Subcensus Tract  
(January 1995)

Census Tract	Subcensus Tract	Existing Units				Additionally Planned Units				Buildout Units			
		SF	TH	MF	TOTAL	SF	TH	MF	TOTAL	SF	TH	MF	TOTAL
221	221.03	88	321		409	65		1,330	1,395	153	321	1,330	1,804
	221.04	31	920	1	952	60	284	205	549	91	1,204	206	1,501
	221.05	14	53	252	319	61	258		319	75	311	252	638
	221.06	38			38	56	122		178	94	122		216
	Census Tract Total	377	1,930	1,243	3,550	300	794	1,535	2,629	677	2,724	2,778	6,179
222	222.01												
	Census Tract Total												
223	223.01	371	672	1,476	2,519	709	16	5	730	1,080	688	1,481	3,249
	Census Tract Total	371	672	1,476	2,519	709	16	5	730	1,080	688	1,481	3,249
224	224.01	308	1,762	1,202	3,272	964	137		1,101	1,272	1,899	1,202	4,373
	224.02	325	144		469	24			24	349	144		493
	Census Tract Total	633	1,906	1,202	3,741	988	137		1,125	1,621	2,043	1,202	4,866
301	301.01	465			465	32			32	497			497
	301.02	1,056			1,056	61			61	1,117			1,117
	301.03	329	652		981	59	81		140	388	733		1,121
	Census Tract Total	1,850	652		2,502	152	81		233	2,002	733		2,735
302	302.01	2,425	1,425		3,850	146	20		166	2,571	1,445		4,016
	Census Tract Total	2,425	1,425		3,850	146	20		166	2,571	1,445		4,016
304	304.01	1,142	326		1,468	1			1	1,143	326		1,469
	304.02	855			855	1			1	856			856
	Census Tract Total	1,997	326		2,323	2			2	1,999	326		2,325
305	305.01	567			567	10			10	577			577
	Census Tract Total	567			567	10			10	577			577
306	306.01	279	106	166	551	17		12	29	296	106	178	580
	306.02	350			350	1			1	351			351
	306.03	257		220	477	1			1	258		220	478
	306.04	435			435	2	32	96	130	437	32	96	565
	Census Tract Total	1,321	106	386	1,813	21	32	108	161	1,342	138	494	1,974
307	307.01	217			217	2	12		14	219	12		231
	307.02	338			338	1			1	339			339

(CONTINUED)

Housing Units at Planned Buildout  
Census and Subcensus Tract  
(January 1995)

Census Tract	Subcensus Tract	Existing Units				Additionally Planned Units				Buildout Units			
		SF	TH	MF	TOTAL	SF	TH	MF	TOTAL	SF	TH	MF	TOTAL
307	307.03	373			373	7			7	380			380
	Census Tract Total	928			928	10	12		22	938	12		950
308	308.01	1,351	1,153	822	3,326	2			2	1,353	1,153	822	3,328
	Census Tract Total	1,351	1,153	822	3,326	2			2	1,353	1,153	822	3,328
309	309.01	847	1,183	242	2,272	247	39		286	1,094	1,222	242	2,558
	Census Tract Total	847	1,183	242	2,272	247	39		286	1,094	1,222	242	2,558
310	310.01	762	1,555		2,317	37	16		53	799	1,571		2,370
	Census Tract Total	762	1,555		2,317	37	16		53	799	1,571		2,370
313	313.01	1,091	302		1,393	48			48	1,139	302		1,441
	Census Tract Total	1,091	302		1,393	48			48	1,139	302		1,441
314	314.01	776	524		1,300	21	13		34	797	537		1,334
	Census Tract Total	776	524		1,300	21	13		34	797	537		1,334
315	315.01	1,154	836		1,990	99	5	15	119	1,253	841	15	2,109
	Census Tract Total	1,154	836		1,990	99	5	15	119	1,253	841	15	2,109
316	316.01	355	187	242	784	417	15	54	486	772	202	296	1,270
	316.02	552	205	99	856	66	11	2	79	618	216	101	935
	316.03	3			3		987	2,963	3,950	3	987	2,963	3,953
	Census Tract Total	910	392	341	1,643	483	1,013	3,019	4,515	1,393	1,405	3,360	6,158
318	318.01	821	1,613		2,434	78	11	3	92	899	1,624	3	2,526
	Census Tract Total	821	1,613		2,434	78	11	3	92	899	1,624	3	2,526
319	319.01	1,048	1		1,049	6			6	1,054	1		1,055
	Census Tract Total	1,048	1		1,049	6			6	1,054	1		1,055
320	320.01	492	617		1,109	5	2		7	497	619		1,116
	Census Tract Total	492	617		1,109	5	2		7	497	619		1,116
321	321.01	501	495	448	1,444	23	6		29	524	501	448	1,473
	Census Tract Total	501	495	448	1,444	23	6		29	524	501	448	1,473
322	322.01	560	1,423	580	2,563	39	5		44	599	1,428	580	2,607
	Census Tract Total	560	1,423	580	2,563	39	5		44	599	1,428	580	2,607
323	323.01	703	410		1,113	6			6	709	410		1,119
	323.02	308	73	100	481	149			149	457	73	100	630

(CONTINUED)

Housing Units at Planned Buildout  
Census and Subcensus Tract  
(January 1995)

Census Tract	Subcensus Tract	Existing Units				Additionally Planned Units				Buildout Units			
		SF	TH	MF	TOTAL	SF	TH	MF	TOTAL	SF	TH	MF	TOTAL
323	Census Tract Total	1,011	483	100	1,594	155			155	1,166	483	100	1,749
324	324.01	2,132	493		2,625	46	5		51	2,178	498		2,676
	Census Tract Total	2,132	493		2,625	46	5		51	2,178	498		2,676
325	325.01	1,391	432		1,823	96			96	1,487	432		1,919
	Census Tract Total	1,391	432		1,823	96			96	1,487	432		1,919
326	326.01	1,109	395		1,504	207			207	1,316	395		1,711
	Census Tract Total	1,109	395		1,504	207			207	1,316	395		1,711
327	327.01	1,040	1,441	78	2,559	165	48		213	1,205	1,489	78	2,772
	Census Tract Total	1,040	1,441	78	2,559	165	48		213	1,205	1,489	78	2,772
328	328.01	264	482		746	51			51	315	482		797
	Census Tract Total	264	482		746	51			51	315	482		797
401	401.01	251	150	300	701	67			67	318	150	300	768
	401.02	1,020			1,020	106			106	1,126			1,126
	401.03	441	161	387	989	75			75	516	161	387	1,064
	Census Tract Total	1,712	311	687	2,710	248			248	1,960	311	687	2,958
402	402.01	1		296	297			288	288	1		584	585
	402.02	415	579	1,088	2,082	29	4	2	35	444	583	1,090	2,117
	402.03												
	402.04	131			131	91			91	222			222
	Census Tract Total	547	579	1,384	2,510	120	4	290	414	667	583	1,674	2,924
403	403.01	471			471	30		18	48	501		18	519
	403.02	447			447	63			63	510			510
	Census Tract Total	918			918	93		18	111	1,011		18	1,029
405	405.01	49	46		95	38			38	87	46		133
	405.02	434			434	36			36	470			470
	405.03	1,569			1,569	104		15	119	1,673		15	1,688
	405.04												
	Census Tract Total	2,052	46		2,098	178		15	193	2,230	46	15	2,291
406	406.01	934			934	197			197	1,131			1,131
	Census Tract Total	934			934	197			197	1,131			1,131

(CONTINUED)

Housing Units at Planned Buildout  
Census and Subcensus Tract  
(January 1995)

Census Tract	Subcensus Tract	Existing Units				Additionally Planned Units				Buildout Units			
		SF	TH	MF	TOTAL	SF	TH	MF	TOTAL	SF	TH	MF	TOTAL
407	407.01	1,660	137		1,797	25			25	1,685	137		1,822
	407.02	989			989	27			27	1,016			1,016
	<b>Census Tract Total</b>	<b>2,649</b>	<b>137</b>		<b>2,786</b>	<b>52</b>			<b>52</b>	<b>2,701</b>	<b>137</b>		<b>2,838</b>
408	408.01	706	35	120	861	29			29	735	35	120	890
	408.02	97			97	7			7	104			104
	408.03	437			437	34			34	471			471
	408.04	668			668	156			156	824			824
	408.05												
	<b>Census Tract Total</b>	<b>1,908</b>	<b>35</b>	<b>120</b>	<b>2,063</b>	<b>226</b>			<b>226</b>	<b>2,134</b>	<b>35</b>	<b>120</b>	<b>2,289</b>
501	501.01	92	348	1,032	1,472	3	488		491	95	836	1,032	1,963
	501.02	203		150	353	3			3	206		150	356
	501.03	350		64	414	7	1		8	357	1	64	422
	<b>Census Tract Total</b>	<b>645</b>	<b>348</b>	<b>1,246</b>	<b>2,239</b>	<b>13</b>	<b>489</b>		<b>502</b>	<b>658</b>	<b>837</b>	<b>1,246</b>	<b>2,741</b>
502	502.01		512		512						512		512
	502.02	243			243	1			1	244			244
	502.03	150		25	175	27	2		29	177	2	25	204
	502.04	392			392	23			23	415			415
	<b>Census Tract Total</b>	<b>785</b>	<b>512</b>	<b>25</b>	<b>1,322</b>	<b>51</b>	<b>2</b>		<b>53</b>	<b>836</b>	<b>514</b>	<b>25</b>	<b>1,375</b>
503	503.01	304			304	13			13	317			317
	503.02	294			294	1			1	295			295
	503.03	194	104	551	849	87	6		93	281	110	551	942
	503.04	227			227	39			39	266			266
	<b>Census Tract Total</b>	<b>1,019</b>	<b>104</b>	<b>551</b>	<b>1,674</b>	<b>140</b>	<b>6</b>		<b>146</b>	<b>1,159</b>	<b>110</b>	<b>551</b>	<b>1,820</b>
504	504.01	275	96		371	28	6		34	303	102		405
	504.02	338			338	8			8	346			346
	504.03	229			229	30			30	259			259
	<b>Census Tract Total</b>	<b>842</b>	<b>96</b>		<b>938</b>	<b>66</b>	<b>6</b>		<b>72</b>	<b>908</b>	<b>102</b>		<b>1,010</b>
505	505.01	360			360	2			2	362			362
	505.02	303			303	8			8	311			311
	505.03	224			224	2			2	226			226

(CONTINUED)

Housing Units at Planned Buildout  
Census and Subcensus Tract  
(January 1995)

Census Tract	Subcensus Tract	Existing Units				Additionally Planned Units				Buildout Units			
		SF	TH	MF	TOTAL	SF	TH	MF	TOTAL	SF	TH	MF	TOTAL
505	Census Tract Total	887			887	12			12	899			899
506	506.01	191			191	72			72	263			263
	506.02	391	96	1,190	1,677	7	9	8	24	398	105	1,198	1,701
	506.03	298			298	5			5	303			303
	506.04	188	2		190					188	2		190
	506.05	257			257	20			20	277			277
	506.06	375			375	15			15	390			390
	506.07	172	2		174	16			16	188	2		190
	Census Tract Total	1,872	100	1,190	3,162	135	9	8	152	2,007	109	1,198	3,314
507	507.01	520	445		965	52			52	572	445		1,017
	507.02	291	2	1,139	1,432	70			70	361	2	1,139	1,502
	Census Tract Total	811	447	1,139	2,397	122			122	933	447	1,139	2,519
508	508.01	294			294	28			28	322			322
	508.02	451			451	11			11	462			462
	508.03	223		184	407	55			55	278		184	462
	Census Tract Total	968		184	1,152	94			94	1,062		184	1,246
509	509.01	286			286	26			26	312			312
	509.02	296			296	10			10	306			306
	Census Tract Total	582			582	36			36	618			618
510	510.01	410			410	1			1	411			411
	510.02	492			492	15			15	507			507
	Census Tract Total	902			902	16			16	918			918
511	511.01	360			360	11			11	371			371
	511.02	451			451	7			7	458			458
	Census Tract Total	811			811	18			18	829			829
512	512.01	226			226	5			5	231			231
	512.02	308			308	6			6	314			314
	512.03	99			99	29			29	128			128
	Census Tract Total	633			633	40			40	673			673
513	513.01	406	25		431	70			70	476	25		501

(CONTINUED)

Housing Units at Planned Buildout  
Census and Subcensus Tract  
(January 1995)

Census Tract	Subcensus Tract	Existing Units				Additionally Planned Units				Buildout Units			
		SF	TH	MF	TOTAL	SF	TH	MF	TOTAL	SF	TH	MF	TOTAL
513	513.02	303	36	108	447	6			6	309	36	108	453
	Census Tract Total	709	61	108	878	76			76	785	61	108	954
514	514.01			204	204							204	204
	514.02			724	724	2			2	2		724	726
	514.03		102	225	327	1	6		7	1	108	225	334
	Census Tract Total		102	1,153	1,255	3	6		9	3	108	1,153	1,264
515	515.01	48	36	898	982	4			4	52	36	898	986
	515.02	325	119	829	1,273	54	14	61	129	379	133	890	1,402
	515.03	245	186	330	761	36	5		41	281	191	330	802
	515.04	63	30	888	981	21		16	37	84	30	904	1,018
	Census Tract Total	681	371	2,945	3,997	115	19	77	211	796	390	3,022	4,208
516	516.01	12		819	831	1		44	45	13		863	876
	516.02	80			80	1			1	81			81
	516.03	98	36	656	790					98	36	656	790
	516.04	166		444	610	29			29	195		444	639
	516.05	215		196	411	12			12	227		196	423
	Census Tract Total	571	36	2,115	2,722	43		44	87	614	36	2,159	2,809
518	518.01	417	48		465	10			10	427	48		475
	518.02	173			173	36			36	209			209
	518.03	426			426	77			77	503			503
	Census Tract Total	1,016	48		1,064	123			123	1,139	48		1,187
519	519.01	440	1,244	525	2,209	124	29	59	212	564	1,273	584	2,421
	Census Tract Total	440	1,244	525	2,209	124	29	59	212	564	1,273	584	2,421
520	520.01	523	354	246	1,123	95			95	618	354	246	1,218
	Census Tract Total	523	354	246	1,123	95			95	618	354	246	1,218
521	521.01	119			119	7			7	126			126
	521.02	378	334	219	931	32	12		44	410	346	219	975
	521.03	315	230		545	43	7		50	358	237		595
	521.04	292	326		618	25			25	317	326		643
	521.05	255	131		386	31	6	6	43	286	137	6	429

(CONTINUED)

Housing Units at Planned Buildout  
Census and Subcensus Tract  
(January 1995)

Census Tract	Subcensus Tract	Existing Units				Additionally Planned Units				Buildout Units			
		SF	TH	MF	TOTAL	SF	TH	MF	TOTAL	SF	TH	MF	TOTAL
521	Census Tract Total	1,359	1,021	219	2,599	138	25	6	169	1,497	1,046	225	2,768
522	522.01	221	336	881	1,438	14			14	235	336	881	1,452
	522.02	383			383	14			14	397			397
	522.03	352			352	2			2	354			354
	Census Tract Total	956	336	881	2,173	30			30	986	336	881	2,203
523	523.01	1	389	2,749	3,139	3	24	40	67	4	413	2,789	3,206
	Census Tract Total	1	389	2,749	3,139	3	24	40	67	4	413	2,789	3,206
524	524.01	507			507	1			1	508			508
	524.02	345			345					345			345
	524.03	284			284	1			1	285			285
	524.04	326		412	738	9			9	335		412	747
	524.05	142	327		469	61	9		70	203	336		539
	Census Tract Total	1,604	327	412	2,343	72	9		81	1,676	336	412	2,424
525	525.01	286			286					286			286
	525.02	384	2		386	56			56	440	2		442
	525.03	337	10		347	24			24	361	10		371
	525.04	264	224	1,065	1,553	201	4	3	208	465	228	1,068	1,761
	Census Tract Total	1,271	236	1,065	2,572	281	4	3	288	1,552	240	1,068	2,860
526	526.01	365		366	731					365		366	731
	526.02	2	148	311	461	290			290	292	148	311	751
	526.03	75	195		270		96		96	75	291		366
	Census Tract Total	442	343	677	1,462	290	96		386	732	439	677	1,848
527	527.01	303	262	1,157	1,722	90	49	29	168	393	311	1,186	1,890
	Census Tract Total	303	262	1,157	1,722	90	49	29	168	393	311	1,186	1,890
528	528.01	350		3,499	3,849	42		88	130	392		3,587	3,979
	Census Tract Total	350		3,499	3,849	42		88	130	392		3,587	3,979
601	601.01	338			338	31			31	369			369
	601.02	658			658	63			63	721			721
	601.03	261			261	168			168	429			429
	Census Tract Total	1,257			1,257	262			262	1,519			1,519

(CONTINUED)

Housing Units at Planned Buildout  
Census and Subcensus Tract  
(January 1995)

Census Tract	Subcensus Tract	Existing Units				Additionally Planned Units				Buildout Units			
		SF	TH	MF	TOTAL	SF	TH	MF	TOTAL	SF	TH	MF	TOTAL
602	602.01	489			489	78			78	567			567
	602.02	62			62	69			69	131			131
	602.03	644			644	42			42	686			686
	Census Tract Total	1,195			1,195	189			189	1,384			1,384
603	603.01	241			241	143			143	384			384
	603.02	660			660	94			94	754			754
	Census Tract Total	901			901	237			237	1,138			1,138
604	604.01	235			235	89			89	324			324
	604.02	416	180	491	1,087	44	173		217	460	353	491	1,304
	604.03	151			151	55			55	206			206
	Census Tract Total	802	180	491	1,473	188	173		361	990	353	491	1,834
605	605.01	570	72		642	240			240	810	72		882
	605.02	279	385	13	677	122	5	2	129	401	390	15	806
	605.03	296	1		297	86			86	382	1		383
	605.04	67	142		209	36	5		41	103	147		250
	605.05	231	335		566	292	8		300	523	343		866
	Census Tract Total	1,443	935	13	2,391	776	18	2	796	2,219	953	15	3,187
606	606.01	147			147	31			31	178			178
	606.02	1,103			1,103	168		101	269	1,271		101	1,372
	Census Tract Total	1,250			1,250	199		101	300	1,449		101	1,550
607 /1	607.01	2,176	216	303	2,695	109	1		110	2,285	217	303	2,805
	Census Tract Total	2,176	216	303	2,695	109	1		110	2,285	217	303	2,805
608 /1	608.01	875	63	185	1,123	49			49	924	63	185	1,172
	Census Tract Total	875	63	185	1,123	49			49	924	63	185	1,172
609 /1	609.01	775	84		859	36			36	811	84		895
	Census Tract Total	775	84		859	36			36	811	84		895
610 /1	610.01	716	81	36	833	33			33	749	81	36	866
	Census Tract Total	716	81	36	833	33			33	749	81	36	866
611	611.01	640			640	73			73	713			713
	611.02	1,062	398	300	1,760	196	22	6	224	1,258	420	306	1,984

(CONTINUED)



Housing Units at Planned Buildout  
Census and Subcensus Tract  
(January 1995)

Census Tract	Subcensus Tract	Existing Units				Additionally Planned Units				Buildout Units			
		SF	TH	MF	TOTAL	SF	TH	MF	TOTAL	SF	TH	MF	TOTAL
611	Census Tract Total	1,702	398	300	2,400	269	22	6	297	1,971	420	306	2,697
612	612.01	194			194	44			44	238			238
	612.02	975	39		1,014	253	2		255	1,228	41		1,269
	612.03	70			70	69			69	139			139
	612.04	10			10	4	56	427	487	14	56	427	497
	Census Tract Total	1,249	39		1,288	370	58	427	855	1,619	97	427	2,143
615	615.01	201	23		224	166	7		173	367	30		397
	615.02	270			270	61			61	331			331
	615.03	174	274		448	40	11	9	60	214	285	9	508
	615.04	22	601		623	49	125	187	361	71	726	187	984
	615.05	89			89					89			89
	Census Tract Total	756	898		1,654	316	143	196	655	1,072	1,041	196	2,309
616	616.01	131	541		672	62	58	8	128	193	599	8	800
	616.02	309	44		353	88	15		103	397	59		456
	616.04	9		783	792			512	512	9		1,295	1,304
	616.05	50	312		362	20	9		29	70	321		391
	616.06	2			2					2			2
	Census Tract Total	501	897	783	2,181	170	82	520	772	671	979	1,303	2,953
617	617.01	31	1,058	750	1,839	235	104	102	441	266	1,162	852	2,280
	617.02	158			158	99		226	325	257		226	483
	Census Tract Total	189	1,058	750	1,997	334	104	328	766	523	1,162	1,078	2,763
618	618.01	66		313	379	40		233	273	106		546	652
	618.02	18	1,263	939	2,220		71	71	142	18	1,334	1,010	2,362
	Census Tract Total	84	1,263	1,252	2,599	40	71	304	415	124	1,334	1,556	3,014
619	619.02	232	176	1,521	1,929	21		50	71	253	176	1,571	2,000
	Census Tract Total	232	176	1,521	1,929	21		50	71	253	176	1,571	2,000
701	701.01	281			281	27			27	308			308
	701.02	447			447	43			43	490			490
	701.03	59			59	50			50	109			109
	701.04	134	35		169	209			209	343	35		378

(CONTINUED)

Housing Units at Planned Buildout  
Census and Subcensus Tract  
(January 1995)

Census Tract	Subcensus Tract	Existing Units				Additionally Planned Units				Buildout Units			
		SF	TH	MF	TOTAL	SF	TH	MF	TOTAL	SF	TH	MF	TOTAL
701	Census Tract Total	921	35		956	329			329	1,250	35		1,285
702	702.01	2			2					2			2
	Census Tract Total	2			2					2			2
703	703.01	667			667	106			106	773			773
	703.02	127			127	30			30	157			157
	703.03	299			299	88			88	387			387
	Census Tract Total	1,093			1,093	224			224	1,317			1,317
704	704.01	295	227		522	139			139	434	227		661
	704.02	43			43	9			9	52			52
	704.03	358			358	138			138	496			496
	704.04	258			258	60			60	318			318
	704.05	498			498	78			78	576			576
	Census Tract Total	1,452	227		1,679	424			424	1,876	227		2,103
705	705.01	110			110	47			47	157			157
	705.02	328			328	5			5	333			333
	705.03	431	281		712	163	4	38	205	594	285	38	917
	705.04	294			294	12			12	306			306
	705.05	157			157	95			95	252			252
	705.06	3		500	503					3		500	503
	Census Tract Total	1,323	281	500	2,104	322	4	38	364	1,645	285	538	2,468
706	706.01	179			179	128			128	307			307
	706.02	126	48		174	38			38	164	48		212
	706.03	244	23	144	411	12	61		73	256	84	144	484
	706.04	158	13		171	12	14	1	27	170	27	1	198
	Census Tract Total	707	84	144	935	190	75	1	266	897	159	145	1,201
707	707.01	278	7		285	16	18	10	44	294	25	10	329
	707.02	397			397	51			51	448			448
	707.03	279	1		280	45			45	324	1		325
	707.04	378			378	2			2	380			380
	707.05	196			196	2			2	198			198

(CONTINUED)

Housing Units at Planned Buildout  
Census and Subcensus Tract  
(January 1995)

Census Tract	Subcensus Tract	Existing Units				Additionally Planned Units				Buildout Units			
		SF	TH	MF	TOTAL	SF	TH	MF	TOTAL	SF	TH	MF	TOTAL
707	707.06	257			257	1			1	258			258
	Census Tract Total	1,785	8		1,793	117	18	10	145	1,902	26	10	1,938
708	708.01	240	32		272	9			9	249	32		281
	708.02	608	175		783	10		33	43	618	175	33	826
	Census Tract Total	848	207		1,055	19		33	52	867	207	33	1,107
709	709.01	493		240	733	90			90	583		240	823
	709.02	495	224		719	33	11		44	528	235		763
	709.03	255			255	13			13	268			268
	709.04	77	251		328	89	56		145	166	307		473
	709.05	323	23		346	51			51	374	23		397
	709.06	105			105	12			12	117			117
	Census Tract Total	1,748	498	240	2,486	288	67		355	2,036	565	240	2,841
710	710.01	58			58	24			24	82			82
	710.02	220			220	37	2		39	257	2		259
	710.03	178	80		258	46		34	80	224	80	34	338
	Census Tract Total	456	80		536	107	2	34	143	563	82	34	679
711	711.01	157	17		174	2			2	159	17		176
	711.02	206			206					206			206
	711.03	267			267	12			12	279			279
	711.04	306			306	3			3	309			309
	711.05	245			245	2			2	247			247
	711.06	335		340	675					335		340	675
	711.07	190			190	6			6	196			196
	711.08	367			367	62			62	429			429
	Census Tract Total	2,073	17	340	2,430	87			87	2,160	17	340	2,517
712	712.01	1			1					1			1
	712.02												
	712.03	44	178		222	18			18	62	178		240
	712.04	45	348	2,401	2,794	41		92	133	86	348	2,493	2,927
	Census Tract Total	90	526	2,401	3,017	59		92	151	149	526	2,493	3,168

(CONTINUED)

Housing Units at Planned Buildout  
Census and Subcensus Tract  
(January 1995)

Census Tract	Subcensus Tract	Existing Units				Additionally Planned Units				Buildout Units			
		SF	TH	MF	TOTAL	SF	TH	MF	TOTAL	SF	TH	MF	TOTAL
713	713.01	269	638	2,385	3,292	150		77	227	419	638	2,462	3,519
	713.02	554	49		603	55	4	72	131	609	53	72	734
	<b>Census Tract Total</b>	<b>823</b>	<b>687</b>	<b>2,385</b>	<b>3,895</b>	<b>205</b>	<b>4</b>	<b>149</b>	<b>358</b>	<b>1,028</b>	<b>691</b>	<b>2,534</b>	<b>4,253</b>
714	714.01	742	523	414	1,679	108	10	18	136	850	533	432	1,815
	714.02	254		639	893	15			15	269		639	908
	<b>Census Tract Total</b>	<b>996</b>	<b>523</b>	<b>1,053</b>	<b>2,572</b>	<b>123</b>	<b>10</b>	<b>18</b>	<b>151</b>	<b>1,119</b>	<b>533</b>	<b>1,071</b>	<b>2,723</b>
801	801.01	373			373	203			203	576			576
	801.02	216	1		217	60			60	276	1		277
	801.03	208			208	168			168	376			376
	801.04	260			260	102			102	362			362
	801.05	203			203	114			114	317			317
	<b>Census Tract Total</b>	<b>1,260</b>	<b>1</b>		<b>1,261</b>	<b>647</b>			<b>647</b>	<b>1,907</b>	<b>1</b>		<b>1,908</b>
802	802.01	315			315	560			560	875			875
	802.02	448			448	112			112	560			560
	802.03	512			512	72			72	584			584
	802.04			2,170	2,170		49	148	197		49	2,318	2,367
	802.05												
	<b>Census Tract Total</b>	<b>1,275</b>		<b>2,170</b>	<b>3,445</b>	<b>744</b>	<b>49</b>	<b>148</b>	<b>941</b>	<b>2,019</b>	<b>49</b>	<b>2,318</b>	<b>4,386</b>
803	803.01	856			856	248			248	1,104			1,104
	803.02	250			250	58			58	308			308
	803.03	824	2		826	623			623	1,447	2		1,449
	803.04	1			1					1			1
	<b>Census Tract Total</b>	<b>1,931</b>	<b>2</b>		<b>1,933</b>	<b>929</b>			<b>929</b>	<b>2,860</b>	<b>2</b>		<b>2,862</b>
804	804.01	591			591	163			163	754			754
	804.02	632			632	232			232	864			864
	804.03	369			369	118			118	487			487
	804.04	364			364	199			199	563			563
	804.05	772			772	196			196	968			968
	<b>Census Tract Total</b>	<b>2,728</b>			<b>2,728</b>	<b>908</b>			<b>908</b>	<b>3,636</b>			<b>3,636</b>
805	805.01	1,691			1,691	244			244	1,935			1,935

(CONTINUED)

Housing Units at Planned Buildout  
Census and Subcensus Tract  
(January 1995)

Census Tract	Subcensus Tract	Existing Units				Additionally Planned Units				Buildout Units			
		SF	TH	MF	TOTAL	SF	TH	MF	TOTAL	SF	TH	MF	TOTAL
805	805.02	1,515	219		1,734	276			276	1,791	219		2,010
	805.03	653	1,077	274	2,004	207	109		316	860	1,186	274	2,320
	Census Tract Total	3,859	1,296	274	5,429	727	109		836	4,586	1,405	274	6,265
808 /2	808.01	1,168	854	494	2,516	529	40	37	606	1,697	894	531	3,122
	Census Tract Total	1,168	854	494	2,516	529	40	37	606	1,697	894	531	3,122
809 /2	809.01	1,530	937	1,377	3,844	273	72	280	625	1,803	1,009	1,657	4,469
	Census Tract Total	1,530	937	1,377	3,844	273	72	280	625	1,803	1,009	1,657	4,469
810	810.01	205	798		1,003	40		623	663	245	798	623	1,666
	Census Tract Total	205	798		1,003	40		623	663	245	798	623	1,666
811	811.01	30			30	3	235	234	472	33	235	234	502
	811.02	315	270	283	868	202	880	1,618	2,700	517	1,150	1,901	3,568
	811.03	1,061			1,061	242			242	1,303			1,303
	811.04	1,268			1,268	167			167	1,435			1,435
	Census Tract Total	2,674	270	283	3,227	614	1,115	1,852	3,581	3,288	1,385	2,135	6,808
812	812.01	1,054	548	694	2,296	129	2		131	1,183	550	694	2,427
	Census Tract Total	1,054	548	694	2,296	129	2		131	1,183	550	694	2,427
814	814.01	1,109	1,127	446	2,682	13			13	1,122	1,127	446	2,695
	Census Tract Total	1,109	1,127	446	2,682	13			13	1,122	1,127	446	2,695
815	815.01	763			763	40			40	803			803
	Census Tract Total	763			763	40			40	803			803
816	816.01	463			463	36			36	499			499
	816.02	557			557	23			23	580			580
	Census Tract Total	1,020			1,020	59			59	1,079			1,079
817	817.01	547			547	182			182	729			729
	817.02	542			542	128			128	670			670
	817.03	616			616	42			42	658			658
	817.04	304	399	1,072	1,775	99	315		414	403	714	1,072	2,189
	Census Tract Total	2,009	399	1,072	3,480	451	315		766	2,460	714	1,072	4,246
819	819.01	153	325	922	1,400	134			134	287	325	922	1,534
	819.02	460			460	161			161	621			621

(CONTINUED)

Housing Units at Planned Buildout  
Census and Subcensus Tract  
(January 1995)

Census Tract	Subcensus Tract	Existing Units				Additionally Planned Units				Buildout Units			
		SF	TH	MF	TOTAL	SF	TH	MF	TOTAL	SF	TH	MF	TOTAL
819	Census Tract Total	613	325	922	1,860	295			295	908	325	922	2,155
820	820.01	861	765	334	1,960	415	111	28	554	1,276	876	362	2,514
	820.02	154	320		474	1			1	155	320		475
	Census Tract Total	1,015	1,085	334	2,434	416	111	28	555	1,431	1,196	362	2,989
821	821.01	90	563	837	1,490					90	563	837	1,490
	Census Tract Total	90	563	837	1,490					90	563	837	1,490
822	822.01		63	260	323		47	438	485		110	698	808
	822.02	50	319		369	1			1	51	319		370
	822.03	74	381	1,605	2,060		1	77	78	74	382	1,682	2,138
	Census Tract Total	124	763	1,865	2,752	1	48	515	564	125	811	2,380	3,316
823	823.01	571	3,036	1,897	5,504	1	65	111	177	572	3,101	2,008	5,681
	Census Tract Total	571	3,036	1,897	5,504	1	65	111	177	572	3,101	2,008	5,681
824	824.01	623			623	145			145	768			768
	Census Tract Total	623			623	145			145	768			768
825	825.01	216			216	27	254	721	1,002	243	254	721	1,218
	825.02	3,309	446		3,755	489			489	3,798	446		4,244
	Census Tract Total	3,525	446		3,971	516	254	721	1,491	4,041	700	721	5,462
826	826.01	602			602	201			201	803			803
	826.02	1,570	1,149		2,719	626	51		677	2,196	1,200		3,396
	Census Tract Total	2,172	1,149		3,321	827	51		878	2,999	1,200		4,199
901	901.01	4			4					4			4
	901.02	12			12	61			61	73			73
	901.03	1,046			1,046	30			30	1,076			1,076
	901.04	1			1	46			46	47			47
	901.05	1,446	647	228	2,321	80			80	1,526	647	228	2,401
	901.06												
	Census Tract Total	2,509	647	228	3,384	217			217	2,726	647	228	3,601
905	905.01	156	311	748	1,215	115			115	271	311	748	1,330
	905.02	1,501	121		1,622	812	91		903	2,313	212		2,525
	Census Tract Total	1,657	432	748	2,837	927	91		1,018	2,584	523	748	3,855

(CONTINUED)

Housing Units at Planned Buildout  
Census and Subcensus Tract  
(January 1995)

Census Tract	Subcensus Tract	Existing Units				Additionally Planned Units				Buildout Units			
		SF	TH	MF	TOTAL	SF	TH	MF	TOTAL	SF	TH	MF	TOTAL
909 /3	909.01	68			68	71			71	139			139
	Census Tract Total	68			68	71			71	139			139
910	910.01	8			8	144			144	152			152
	910.02	497			497	377			377	874			874
	Census Tract Total	505			505	521			521	1,026			1,026
911	911.01	2,172	2,052		4,224	233			233	2,405	2,052		4,457
	Census Tract Total	2,172	2,052		4,224	233			233	2,405	2,052		4,457
912	912.01	365	1,477	252	2,094	33	336	65	434	398	1,813	317	2,528
	912.02					11	421	838	1,270	11	421	838	1,270
	Census Tract Total	365	1,477	252	2,094	44	757	903	1,704	409	2,234	1,155	3,798
913	913.01	22			22	58			58	80			80
	913.02	36			36	22			22	58			58
	913.03	217	73	282	572	63	150		213	280	223	282	785
	913.04	494	1,598	1,148	3,240	514	465	239	1,218	1,008	2,063	1,387	4,458
	Census Tract Total	769	1,671	1,430	3,870	657	615	239	1,511	1,426	2,286	1,669	5,381
914	914.01	2,053	3,231	516	5,800	398	257	33	688	2,451	3,488	549	6,488
	Census Tract Total	2,053	3,231	516	5,800	398	257	33	688	2,451	3,488	549	6,488
915	915.01	1,439	1		1,440	736			736	2,175	1		2,176
	915.02	167	387		554	489	180		669	656	567		1,223
	915.03	5		164	169	3		38	41	8		202	210
	Census Tract Total	1,611	388	164	2,163	1,228	180	38	1,446	2,839	568	202	3,609
916	916.01	1,366	1,126	1	2,493	132	26	17	175	1,498	1,152	18	2,668
	Census Tract Total	1,366	1,126	1	2,493	132	26	17	175	1,498	1,152	18	2,668
917	917.01	14	741	770	1,525	29	573	375	977	43	1,314	1,145	2,502
	917.02	5		737	742	15	15		30	20	15	737	772
	917.03	88			88	850			850	938			938
	917.04	102	299	768	1,169	131	130	280	541	233	429	1,048	1,710
	Census Tract Total	209	1,040	2,275	3,524	1,025	718	655	2,398	1,234	1,758	2,930	5,922
918	918.01	1,940	501	1,693	4,134	140			140	2,080	501	1,693	4,274
	Census Tract Total	1,940	501	1,693	4,134	140			140	2,080	501	1,693	4,274

(CONTINUED)

Housing Units at Planned Buildout  
Census and Subcensus Tract  
(January 1995)

Census Tract	Subcensus Tract	Existing Units				Additionally Planned Units				Buildout Units			
		SF	TH	MF	TOTAL	SF	TH	MF	TOTAL	SF	TH	MF	TOTAL
919	919.01	104			104	103			103	207			207
	919.02	124			124	59		59	183			183	
	919.03	150			150	70		70	220			220	
	919.04	56			56	11		11	67			67	
	919.05	114			114	244		244	358			358	
	919.06	40			40	18		18	58			58	
	919.07	93			93	80		80	173			173	
	919.08	17			17	5		5	22			22	
	919.09	114			114	16		16	130			130	
	919.10	43			43	2		2	45			45	
	919.11	46			46	10		10	56			56	
	919.12	91			91	10		10	101			101	
		<b>Census Tract Total</b>	<b>992</b>			<b>992</b>	<b>628</b>		<b>628</b>	<b>1,620</b>			<b>1,620</b>
920	920.01	652			652	265		265	917			917	
	920.02	653	2		655	82		82	735	2		737	
	920.03	670			670	111		111	781			781	
		<b>Census Tract Total</b>	<b>1,975</b>	<b>2</b>		<b>1,977</b>	<b>458</b>		<b>458</b>	<b>2,433</b>	<b>2</b>		<b>2,435</b>
921	921.01	82			82	18		18	100			100	
	921.02	127			127	42		42	169			169	
	921.03	331			331	76		76	407			407	
	921.04	220			220	12		12	232			232	
	921.05	276			276	171		171	447			447	
	921.06	353			353	46		46	399			399	
	921.07	747			747	14		14	761			761	
		<b>Census Tract Total</b>	<b>2,136</b>			<b>2,136</b>	<b>379</b>		<b>379</b>	<b>2,515</b>			<b>2,515</b>
922	922.01	116			116	32	4	4	40	148	4	4	156
	922.02	435			435	449		449	884			884	
	922.03	1,738	122		1,860	309	79	388	2,047	201		2,248	
	922.04	199			199	151		151	350			350	
	922.05	1,014			1,014	387		387	1,401			1,401	

(CONTINUED)



Housing Units at Planned Buildout  
Census and Subcensus Tract  
(January 1995)

Census Tract	Subcensus Tract	Existing Units				Additionally Planned Units				Buildout Units			
		SF	TH	MF	TOTAL	SF	TH	MF	TOTAL	SF	TH	MF	TOTAL
922	Census Tract Total	3,502	122		3,624	1,328	83	4	1,415	4,830	205	4	5,039
923	923.01	616	467		1,083	42			42	658	467		1,125
	Census Tract Total	616	467		1,083	42			42	658	467		1,125
924	924.01	307	1,211		1,518	182			182	489	1,211		1,700
	Census Tract Total	307	1,211		1,518	182			182	489	1,211		1,700
<b>TOTAL</b>		<b>172,359</b>	<b>77,356</b>	<b>78,436</b>	<b>328,151</b>	<b>38,059</b>	<b>10,752</b>	<b>15,421</b>	<b>64,232</b>	<b>210,418</b>	<b>88,108</b>	<b>93,857</b>	<b>392,383</b>

- 1/ Comprises part of the Town of Vienna (Vienna is composed of Census Tracts 607 through 610).
- 2/ Comprises part of the Town of Herndon (Herndon is composed of Census Tracts 808 and 809).
- 3/ Town of Clifton (Clifton is composed of Census Tract 909).