

Nonresidential Outdoor Lighting Zoning Regulations Overview



To reduce unwanted glare, the Zoning Ordinance contains standards for outdoor lighting.

What's Required?

- Fixtures must be **full cut-off and mounted horizontal** to the ground. Full cut-off means that light is not emitted above the bottom of the fixture.
- Lights must have a **color temperature** of 3,000K or less, except with an approved sports illumination plan. Check the package for this information.
- **Spotlighting** of flags, landscaping, or other similar objects must be aimed and shielded to confine the light to the object.
- On lots adjacent to residential, all lights must have a **setback** based on their height or have additional **shielding**.
- Parking lots with 4 or more light poles must **dim the lights** by 50% within 30 minutes after closing.
- **Maximum height:** 40 ft. (20 ft. on the top of parking decks). Light poles 7 ft. high or less are allowed in any location; higher poles must meet setbacks, except in parking lots.
- **Roofs and canopies** cannot use lights with clear or translucent white, off-white or yellow casing.
- Sports fields/courts, including pools, over 10,000 square feet or with light poles that are 20 ft. high, are required to have an approved **sports illumination plan**.
- Service stations and vehicle sales uses must have an approved **photometric plan**.
- Additional requirements apply to **signs**.

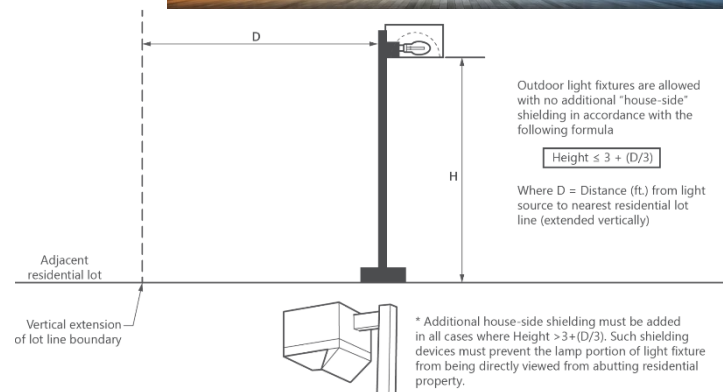
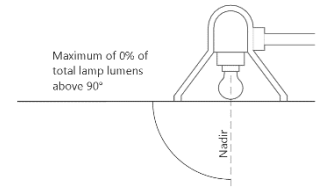

What's Exempt?

- Lights do not need to be full cut-off or meet the setback/shielding requirement if they are **motion-activated** and the light is directed within the property.
- Holiday lighting.
- Depending on when the light was installed, it may be allowed to remain as is.

Complaints:

To report a possible violation, please contact the Department of Code Compliance at 703.324.1300 (TTY 711) or send an email to: DCCCodeComplianceE-mail@fairfaxcounty.gov

Contact Us:

If you have any questions about these outdoor lighting regulations, please contact the Zoning Administration Division at 703.324.1314 (TTY 711) or send an email to: ORDADMIN@fairfaxcounty.gov

This publication summarizes a few regulations as of July 1, 2021. See the Fairfax County Zoning Ordinance for specific requirements.